

THIS IS AN UNCONTROLLED DOCUMENT. THE DATA IS PRESENTED FOR GENERAL INFORMATION ONLY. SOME INFORMATION HAS BEEN SUPERCEDED SINCE ORIGINAL PUBLICATION. PLEASE REFER TO THE CURRENT PRODUCT SPECIFICATION BOOKLET FOR UP-TO-DATE STANDARD EQUIPMENT LIST & KIT WEIGHTS, PERFORMANCE, AND DIRECT OPERATING COST.

Bell 206B-3



Product Data

THIS IS AN UNCONTROLLED DOCUMENT. THE DATA IS PRESENTED FOR GENERAL INFORMATION ONLY. SOME INFORMATION HAS BEEN SUPERCEDED SINCE ORIGINAL PUBLICATION. PLEASE REFER TO THE CURRENT PRODUCT SPECIFICATION BOOKLET FOR UP-TO-DATE STANDARD EQUIPMENT LIST & KIT WEIGHTS, PERFORMANCE, AND DIRECT OPERATING COST.

PUBLISHERS NOTICE

The data presented in this document is **GENERAL** in nature, and has been compiled from Bell Helicopter Textron Inc. [**BHTI**] publications including but not limited to; The Model 206B3 Rotorcraft Flight Manual & Manufacturers Data, The Model 206B3 Maintenance Manual, The Model 206B3 Illustrated Parts Catalog, and **BHTI** Training Academy Model 206B3 Pilot and Mechanic Course Manuals.

This document is intended for the use of **BHTI Sales Personnel** and for **prospective customers** as an aid in defining the features and benefits of the Bell Model 206B3 .

This document contains **proprietary material** of **BHTI**. Disclosure, reproduction, or use of any material in this document by persons **other than BHTI employees, and BHTI Independent Representatives [International Dealers]** is forbidden without written permission from **BHTI**.

The **PHOTOGRAPHS** and **DRAWINGS** used in this book are for **illustration** only, and may differ from the actual aircraft, as the **BHTI** continuing product improvement process causes some components, specifications, and procedures to be changed or replaced.

For the **MOST CURRENT** Model 206B3 tabular data, standard equipment list, optional equipment kits, and performance and fuel flow charts refer to the Bell 206B3 Technical Information Booklet. For performance and operational limitations for **actual mission planing** reference must ALWAYS be made to the FAA Approved Rotorcraft Flight Manual.

THIS IS AN UNCONTROLLED DOCUMENT. THE DATA IS PRESENTED FOR GENERAL INFORMATION ONLY. SOME INFORMATION HAS BEEN SUPERCEDED SINCE ORIGINAL PUBLICATION. PLEASE REFER TO THE CURRENT PRODUCT SPECIFICATION BOOKLET FOR UP-TO-DATE STANDARD EQUIPMENT LIST & KIT WEIGHTS, PERFORMANCE, AND DIRECT OPERATING COST.

CONTENTS

SECTION ONE	GENERAL DESCRIPTION STANDARD CONFIGURATION
SECTION TWO	DESCRIPTIVE SUMMARY STANDARD CONFIGURATION
SECTION THREE	OPTIONAL EQUIPMENT
SECTION FOUR	CUSTOMIZING AND VENDOR EQUIPMENT
SECTION FIVE	DIMENSIONS AND WEIGHTS
SECTION SIX	PERFORMANCE
SECTION SEVEN	TYPICAL MISSIONS
SECTION EIGHT	TRAINING
SECTION NINE	CUSTOMER SUPPORT AND SERVICES
SECTION TEN	COST OF OPERATIONS

INTERNATIONALLY APPROVED ABBREVIATIONS

Atmosphere	C	Degrees Celsius (° is not required if meaning is clear.)
	ISA	International standard atmosphere. (Standard temperature is defined as 15°C at sea level, with a lapse rate of -1°C for each 150 meters (500 feet), increase in pressure altitude.)
	ISA+20 C ISA+30 C	International standard temperatures increased at each altitude by a constant 20 C or 30 C.
	SL	Sea level.
<hr/>		
Rate of Climb	R/C	Rate of climb.
	ft/min	Feet per minute.
	m/s	Meters per second. (One meter per second is 3.28 ft/s.)
<hr/>		
Speed and Distance	h	Hour/hours.
	km	Kilometer/kilometers.
	km/h	Kilometers per hour. (One kilometer per hour equals 0.54 knots or 0.62 statute miles per hour.)
	kn	Knots. (Nautical miles per hour.)
	m	Meter/meters. (One meter equals 3.28 feet.)
	mph	Statute miles per hour. (One mile per hour equals 0.87 knots.)
	nm sm	Nautical miles. Statute miles.
<hr/>		
Weights	kg	Kilogram/kilograms.
	lb	Pound/pounds. (One pound equals 0.45 kilograms.)
<hr/>		
Performance Definitions	IGE	In ground effect. (Hovering near the ground creates a cushion of air that increases the weight carrying capability of the helicopter (the ground effect). This effect generally is present up to one rotor diameter above the ground.)
	OGE	Out of ground effect. (Since the ground effect extends up to one rotor diameter out of ground effect refers to flight that is higher than this height above the ground.)
	max	Maximum.
	Maximum Endurance Speed	The speed at which power required to fly is a minimum.
	Long Range Cruise Speed	The higher of the two speeds at which 99% of maximum range occurs. Cruising at this speed is a tradeoff of one percent in maximum range for 20 to 30 kilometers per hour (10 to 15 knots), higher speed.
	Pressure Altitude	The altitude indicated on an altimeter or barometer when the sea level standard pressure reading is the reference (1013 millibars (29.92 inches) of mercury).
Service Ceiling	The altitude at which the maximum rate of climb capability is 0.5 meters per second, 100 feet per minute.	

THIS IS AN UNCONTROLLED DOCUMENT. THE DATA IS PRESENTED FOR GENERAL INFORMATION ONLY. SOME INFORMATION HAS BEEN SUPERCEDED SINCE ORIGINAL PUBLICATION. PLEASE REFER TO THE CURRENT PRODUCT SPECIFICATION BOOKLET FOR UP-TO-DATE STANDARD EQUIPMENT LIST & KIT WEIGHTS, PERFORMANCE, AND DIRECT OPERATING COST.

SECTION ONE

GENERAL DESCRIPTION

BELL 206B, JETRANGER III



THIS IS AN UNCONTROLLED DOCUMENT. THE DATA IS PRESENTED FOR GENERAL INFORMATION ONLY. SOME INFORMATION HAS BEEN SUPERCEDED SINCE ORIGINAL PUBLICATION. PLEASE REFER TO THE CURRENT PRODUCT SPECIFICATION BOOKLET FOR UP-TO-DATE STANDARD EQUIPMENT LIST & KIT WEIGHTS, PERFORMANCE, AND DIRECT OPERATING COST.

PUBLISHERS NOTICE

The data presented in this document is **GENERAL** in nature, and has been compiled from Bell Helicopter Textron Inc. [**BHTI**] publications including but not limited to; The Model 206B3 Rotorcraft Flight Manual & Manufacturers Data, The Model 206B3 Maintenance Manual, The Model 206B3 Illustrated Parts Catalog, and **BHTI** Training Academy Model 206B3 Pilot and Mechanic Course Manuals.

This document is intended for the use of **BHTI Sales Personnel** and for **prospective customers** as an aid in defining the features and benefits of the Bell Model 206B3 .

This document contains **proprietary material** of **BHTI**. Disclosure, reproduction, or use of any material in this document by persons **other than BHTI employees, and BHTI Independent Representatives [International Dealers]** is forbidden without written permission from **BHTI**.

The **PHOTOGRAPHS** and **DRAWINGS** used in this book are for **illustration** only, and may differ from the actual aircraft, as the **BHTI** continuing product improvement process causes some components, specifications, and procedures to be changed or replaced.

For the **MOST CURRENT** Model 206B3 tabular data, standard equipment list, optional equipment kits, and performance and fuel flow charts refer to the Bell 206B3 Technical Information Booklet. For performance and operational limitations for **actual mission planing** reference must **ALWAYS** be made to the FAA Approved Rotorcraft Flight Manual.



HISTORICAL REVIEW

The JetRanger was designed in April 1965 specifically for the commercial market as a turbine-powered light utility helicopter. Construction began in July 1965 and the first flight took place on the 10th of January 1966. By October it was fully certificated and by January 1967 was in full production.

Modified versions entered military service -- the OH-58A for the U.S. Army and the TH-57 for the U.S. Navy. Another version, the B/A 206B-1 was built in Australia for the Australian Army.

By the end of 1989, 7500 have been sold and are operating in 84 countries. It has proven to be the **most popular light turbine helicopter in history.**

The JetRanger has been modified throughout its life to stay **thoroughly modern and up-to-date.**

Since 1967 thousands of improvements have been made, most of which can be retrofitted to every JetRanger in the field.

Major changes introduced the JetRanger II in 1972 and the JetRanger III in 1977. The most important of which was the increase in horsepower from the original 236.4kW (317 shp) to the present 313 kW (420 shp).

In spite of its maturity all the advantages of today's technology have been and are being applied. This has resulted in a unique combination of **proven reliability and economy of operation.** The two-bladed rotor system is still the simplest to maintain. It is in use all over the world in more applications than any other. Added to the profitable characteristic of **simple in-the-field maintenance** is the solid support which Bell supplies in the upkeep of all Bell helicopters. Maintenance support is specifically tailored to match the customer, his environment and his mission.

In August 1982 Dick Smith flew his JetRanger, solo from Fort Worth, Texas to Sydney, Australia via London, a distance of 18,700 nautical miles in 174 hours, 39 minutes.



JetRanger III



THIS IS AN UNCONTROLLED DOCUMENT. THE DATA IS PRESENTED FOR GENERAL INFORMATION ONLY. SOME INFORMATION HAS BEEN SUPERCEDED SINCE ORIGINAL PUBLICATION. PLEASE REFER TO THE CURRENT PRODUCT SPECIFICATION BOOKLET FOR UP-TO-DATE STANDARD EQUIPMENT LIST & KIT WEIGHTS, PERFORMANCE, AND DIRECT OPERATING COST.

BELL 206B JETRANGER III

In 1986, production of the Model 206 series was transferred to Bell Helicopter Canada, a division of Textron Canada Ltd. The manufacturing facilities are situated in Mirabel, Quebec, 30 kilometers (19 miles) north of Montreal. The plant is a short drive from Dorval Airport for United States and Canadian arrivals, and only minutes from Mirabel International Airport.

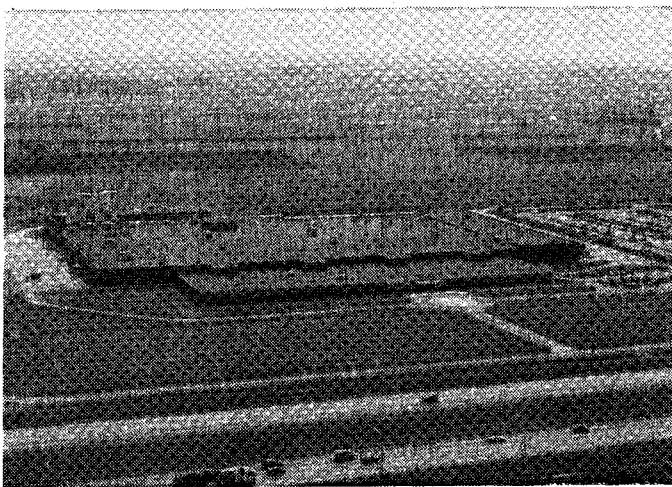
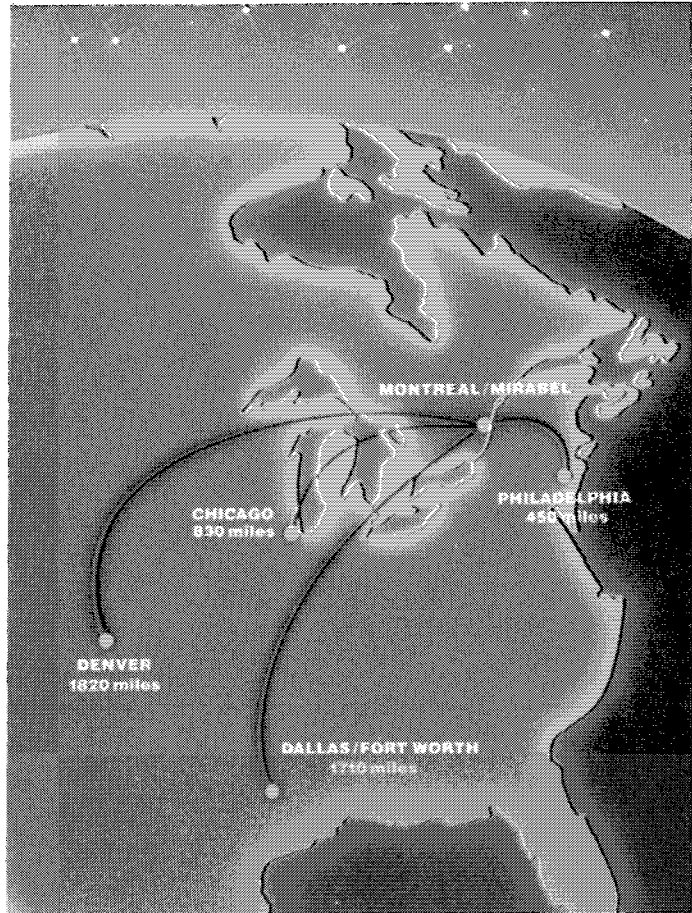

Current production JetRanger III helicopters are manufactured to the same high standards specified by the Federal Aviation Agency (FAA) of the United States. Design approval as a normal category rotorcraft under Civil Air Regulation (CAR) Part 6, is contained on US Type Certificate H2SW.



THIS IS AN UNCONTROLLED DOCUMENT. THE DATA IS PRESENTED FOR GENERAL INFORMATION ONLY. SOME INFORMATION HAS BEEN SUPERCEDED SINCE ORIGINAL PUBLICATION. PLEASE REFER TO THE CURRENT PRODUCT SPECIFICATION BOOKLET FOR UP-TO-DATE STANDARD EQUIPMENT LIST & KIT WEIGHTS, PERFORMANCE, AND DIRECT OPERATING COST.

BELL 206B *JETRANGER III*

The corresponding certification approvals have been issued to Bell Mirabel by Transport Canada (Canada's Civil Aviation Authority) and are accepted under a bilateral agreement between the United States and Canada. They are Manufacturing Approval 1-86, and Canadian Type Approval H92.

A new JetRanger III is delivered with a Canadian Export Certificate of Airworthiness, which may be readily exchanged for a Certificate of Airworthiness in the destination country.





THIS IS AN UNCONTROLLED DOCUMENT. THE DATA IS PRESENTED FOR GENERAL INFORMATION ONLY. SOME INFORMATION HAS BEEN SUPERCEDED SINCE ORIGINAL PUBLICATION. PLEASE REFER TO THE CURRENT PRODUCT SPECIFICATION BOOKLET FOR UP-TO-DATE STANDARD EQUIPMENT LIST & KIT WEIGHTS, PERFORMANCE, AND DIRECT OPERATING COST.

**BELL 206B
JETRANGER III**

**GENERAL DESCRIPTION
OF THE STANDARD CONFIGURATION**

Serial No. 4041 and subsequent

THE JETRANGER III is the smallest member of the current Bell fleet, yet it carries five adults in comfortable, forward-facing seats.



JetRanger III

017154

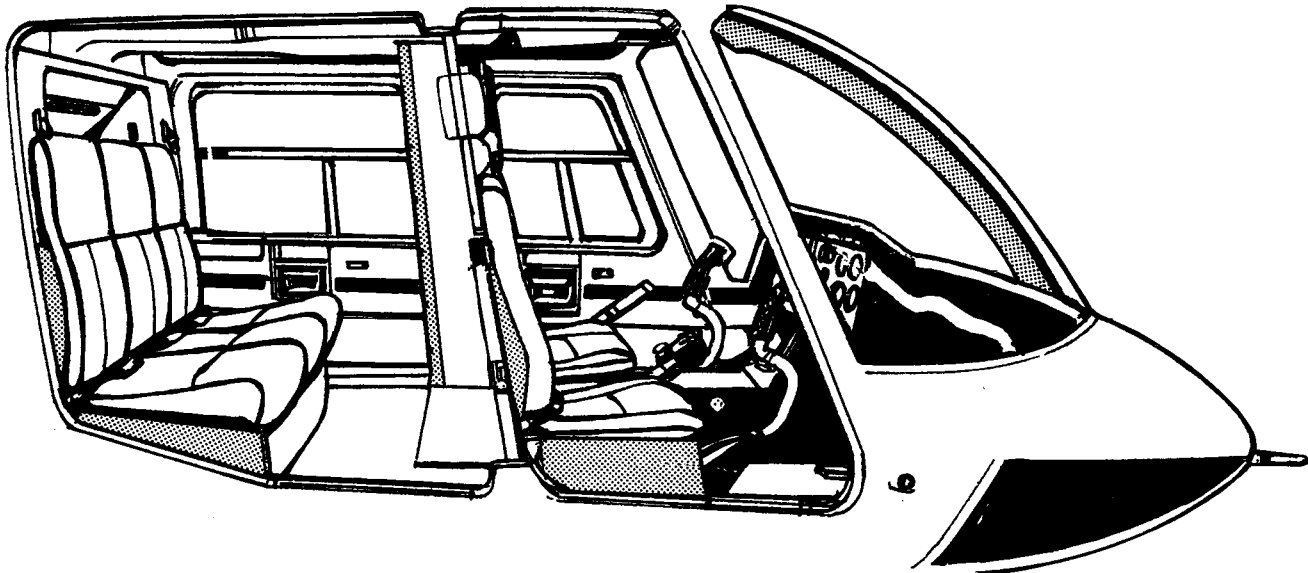



THIS IS AN UNCONTROLLED DOCUMENT. THE DATA IS PRESENTED FOR GENERAL INFORMATION ONLY. SOME INFORMATION HAS BEEN SUPERCEDED SINCE ORIGINAL PUBLICATION. PLEASE REFER TO THE CURRENT PRODUCT SPECIFICATION BOOKLET FOR UP-TO-DATE STANDARD EQUIPMENT LIST & KIT WEIGHTS, PERFORMANCE, AND DIRECT OPERATING COST.

BELL 206B JETRANGER III

The JetRanger has attractive lines and its polyurethane finish is the best available anywhere. Polyurethane paint is not only durable, it is eye catching and it is easy to keep sparkling clean.

The standard JetRanger is finished in one of the three designs illustrated below. The three colors used in each of them are selected from the IMRON color chip chart available from the Bell representative.

Design A

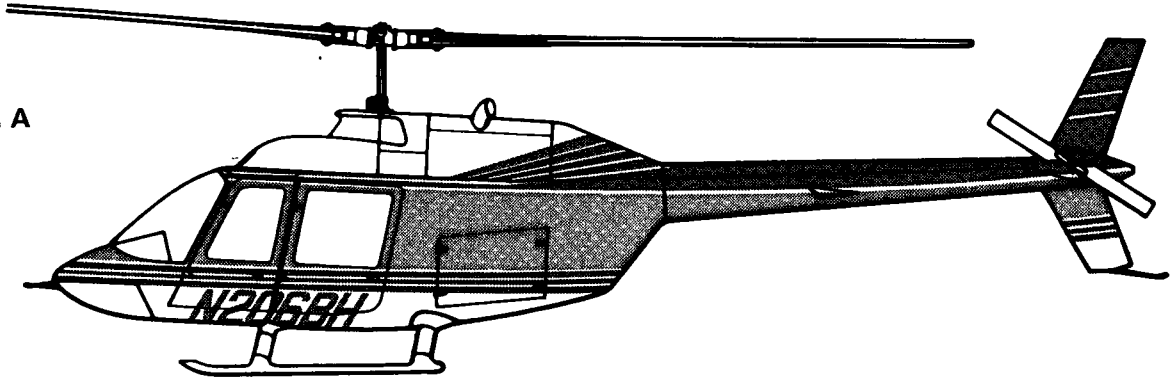

Design B

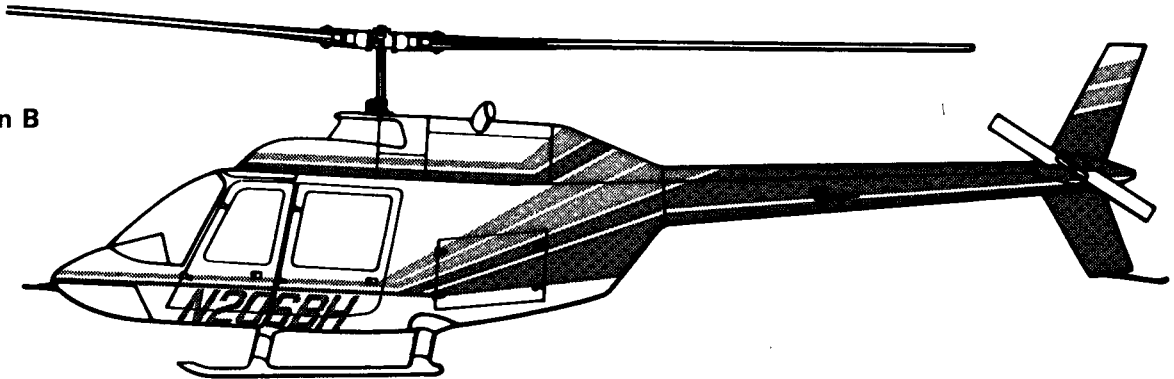

Design C

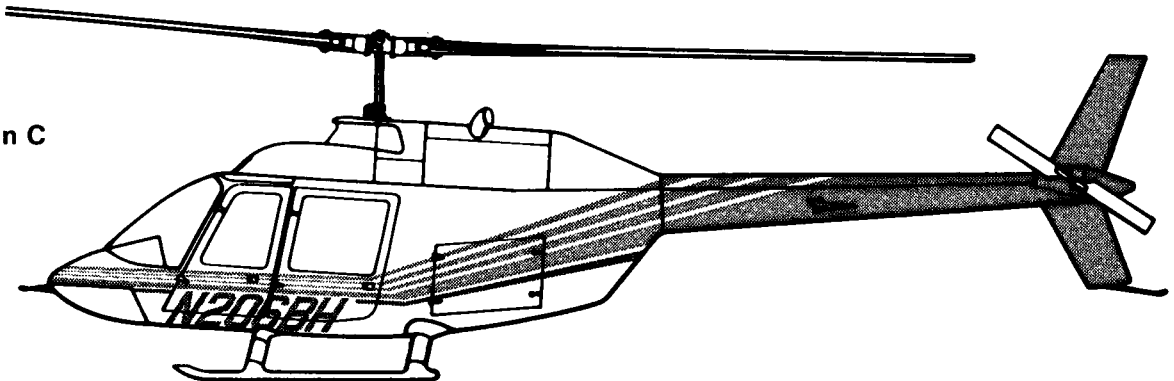

Special company colors, paint design, logos, etc. can be negotiated.



The JetRanger is designed for **single pilot operation** from the right front seat. A passenger seat is provided on the left.



Crew Compartment

Three passengers can be accommodated in the spacious aft cabin.



**Passenger Compartment
Shown with Optional Heater Ducts**

023716

THE INTERIOR is beautifully appointed for the **personnel transport** role.

Each of the **five seats** is based on a pair of tubular metal frames; one for the seat and one for the seat back. Each frame has its own cushion. These start with a neoprene membrane which provides excellent support and vibration isolation. Foam adds to the comfort and then the whole unit is furnished in a fabric with a matching vinyl trim.

A **lumbar support** is built into the seat back. The position of the support can be adjusted in the two front seats by pulling a pair of tabs that are on the center section.

The seat-back is pushed up into position into two pairs of metal hooks. It is held in place at the bottom when the seat is positioned. The seat is secured by a single pin pushed through the two eyes on the forward edge.



Seat Construction

023623

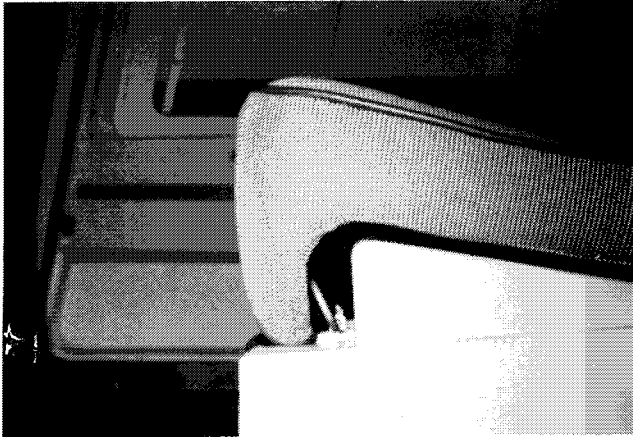

Seat Secured

23727

There are **four attractive interiors** to choose from.

The standard interior comes in a choice of **four fabric and vinyl color combinations**, all painstakingly tailored to ensure they are as comfortable, attractive and safe as possible. The colors are brown, beige, red and blue.

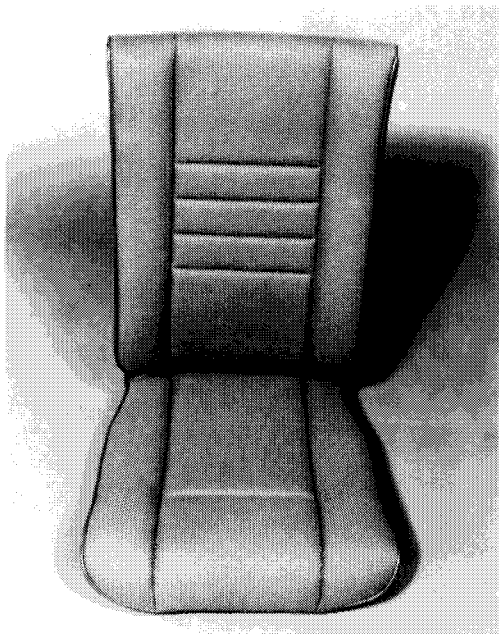

Fabric and Vinyl

22614

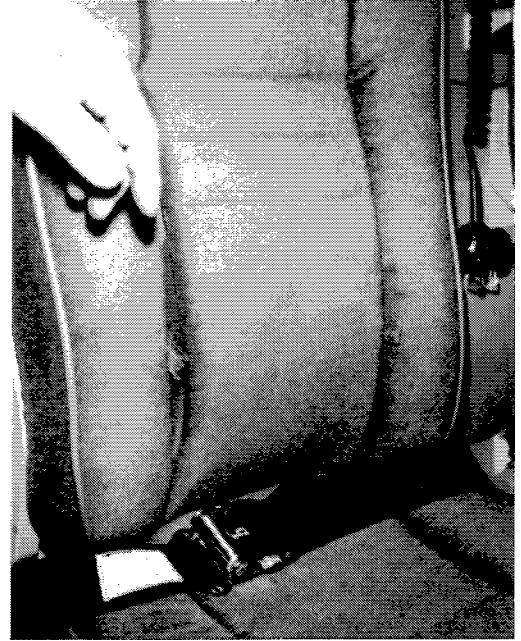

Lumbar Adjustor

23731

The **plastic trim** and the **painted interior surfaces** are furnished in neutral off-white and beige. The trim consists of window frames, headliners for the ceiling, coverings for the vertical control tunnel, the parcel shelf behind the rear seat and the lower part of each door.



Plastic trim closes out both sides of the two front seats and the outboard sides of the back row of seats. The pins that secure the seats remain accessible.

The floor and the areas likely to be scuffed are covered with a lightweight aircraft carpet --color- coordinated to complement the choice of seat material. Where the carpet is continued up the scuff panels it is finished with a plastic edging.

The Bell representative has a book containing actual samples of the standard Fabrics, vinyl, trim, and carpets.

Ample foot room is available for all the passengers and the floor is flat.



**Comfortable, Attractive
Shown with Optional Heater Ducts**

23623

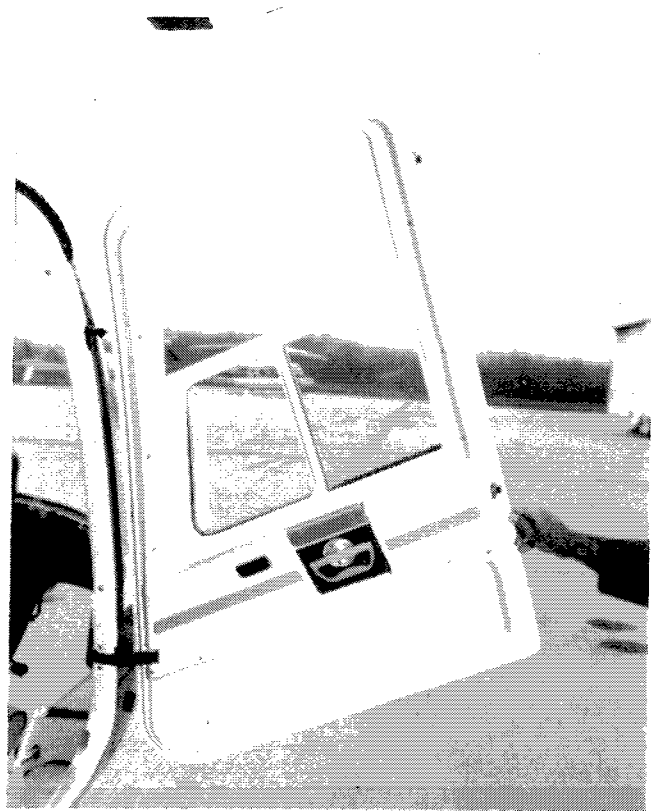

Pilot's Door

23722

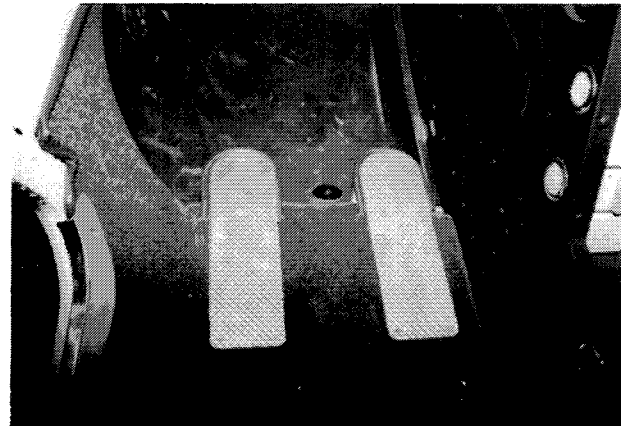

Door Sill, Foot Plates

02446

Each door has a nylon web restraining strap and each is accented with an attractive plastic stripe.

Door sills are metal. A pair of metal plates are installed on the floor at both front seats to minimize carpet wear.

All the materials used in the JetRanger interior are selected for their high resistance to sun, cold and heat in order to prolong their attractive appearance. They are also highly resistant to the fuels and oils normally associated with flying. Cleaning techniques follow normal practices for the care of fine

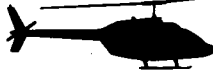

fabrics. All the materials have met the strict standards for fire resistance and low toxicity.

Ample space is provided on the Radio Pedestal for optional Avionics Kits. In addition there is space provision for the **OPTIONAL Ash Tray Kit**. An **OPTIONAL Passenger Ash Tray Kit** (two ashtrays) is also available for the rear cabin.

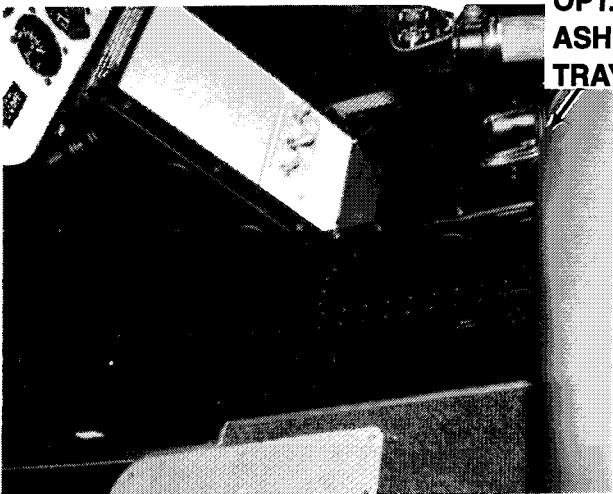

**OPT.
ASH
TRAY**

Radio Pedestal

02272

Five seat belts are provided. The two front seats have dual-strap harnesses, the aft seats each have a single shoulder strap. All



are mounted on individual inertia-reels and are in woven black nylon with chrome fittings. The shoulder strap snaps into the seat belt fastener usually after the seat belt is snugly in place. However, when the seat belt is unfastened, the passenger is free to exit.

The outboard seat belt segment of each outboard seat is protected by a vinyl sleeve. The protective sleeve prevents the seat belt from becoming caught between the door and fuselage when a seat is vacant.



Releasing Passenger Seat Belt



THIS IS AN UNCONTROLLED DOCUMENT. THE DATA IS PRESENTED FOR GENERAL INFORMATION ONLY. SOME INFORMATION HAS BEEN SUPERCEDED SINCE ORIGINAL PUBLICATION. PLEASE REFER TO THE CURRENT PRODUCT SPECIFICATION BOOKLET FOR UP-TO-DATE STANDARD EQUIPMENT LIST & KIT WEIGHTS, PERFORMANCE, AND DIRECT OPERATING COST.

BELL 206B JETRANGER III

Headrests are provided for the two front seats.



Passenger Compartment Trim

Soundproofing blankets are installed on the cabin ceiling and one is installed behind the parcel shelf. These are made of a fiberglass batting filling and a quilted cover.

The blankets are covered with the plastic headliners which have soft fabric inserts giving a soft look to the cabin ceiling. A one piece trim unit covers the parcel shelf area.

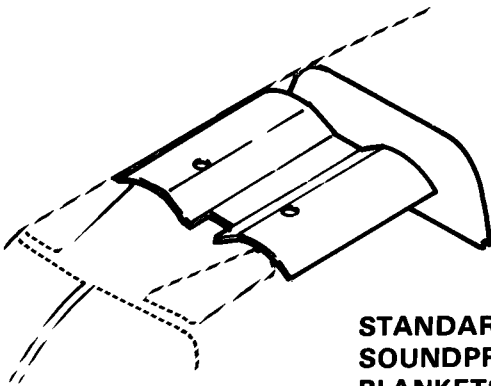

STANDARD
SOUNDPROOF
BLANKETS

FOUR LARGE DOORS are hinged forward and open wide for easy access. The low door sills, about 50 centimeters high (20 inches), make entry or exit comfortable without additional steps.

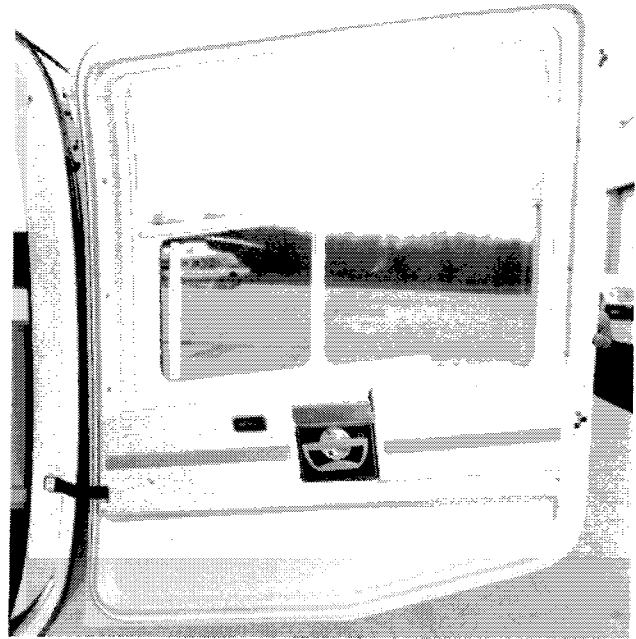

Passenger Door

023721



Low Silhouette

004483



The windows in the two rear doors are bulged. This provides an arm rest and more than ten centimeters (four inches) additional **shoulder room** for each of the two outside passengers. Downward visibility is also increased.

All the windows, windshields and chin bubbles are made of blue tinted acrylic. The two sky lights are of polycarbonate and have a heavier tint. The tint provides shielding from direct sunlight without interfering with the excellent all around visibility.

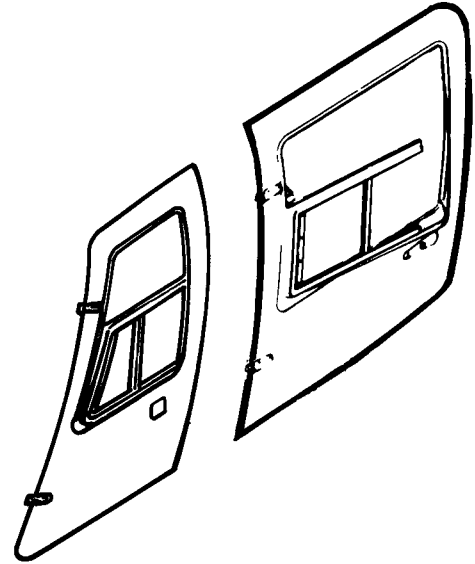
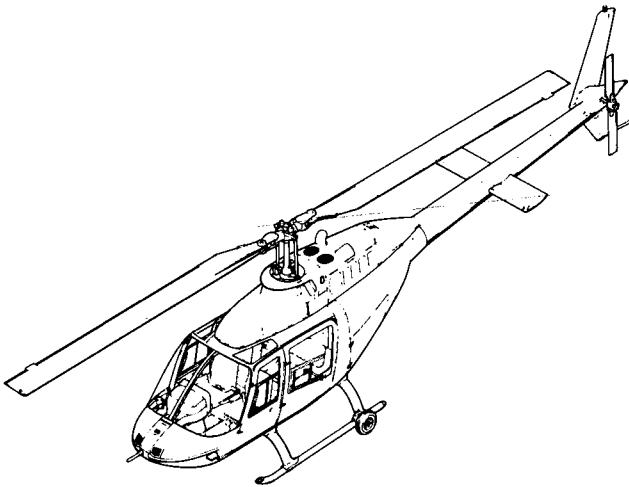

The doors can be removed if mission requirements so dictate. Any flight limits imposed are detailed in the flight manual.

The four doors have a **slam-closing** feature and a **dual point latching** system.



Convenient Entrance

014194M



Doors-Off Operations

019914



The exterior handles are recessed so that they are flush with the door surface. They are elongated for easy operation and are hinged at the aft end.



Outside Handle Closed

23724

The interior handles are the hinged, D-ring, rotary type. The D-ring provides a handhold to pull the door closed, however a metal hand grip is also provided.

The ring is turned to open the door. Once the door is closed an additional turning motion locks the system.

All our doors can be locked from the outside with one key.

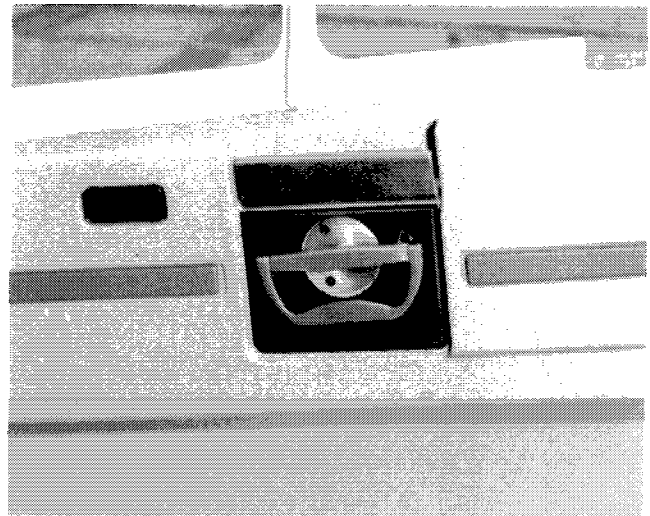

Inside Handle

023726

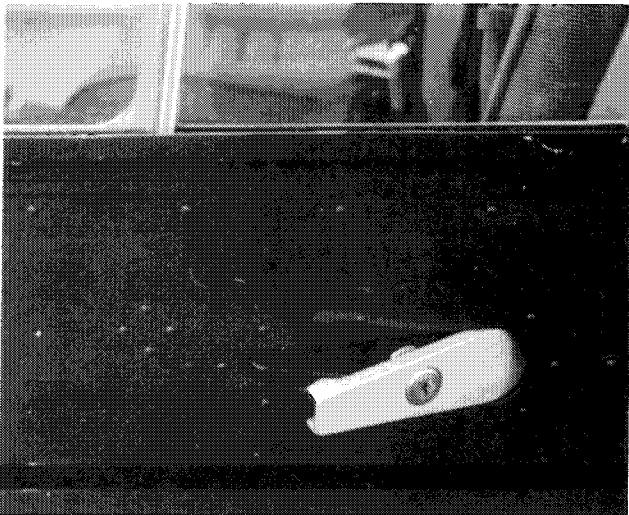

Outside Handle Open

23725



All door openings have effective rain seals. A rain gutter extends along the fuselage immediately above the door openings.



Rain Gutters

310738



Excellent Observation

02279

Visibility is excellent from all seats.

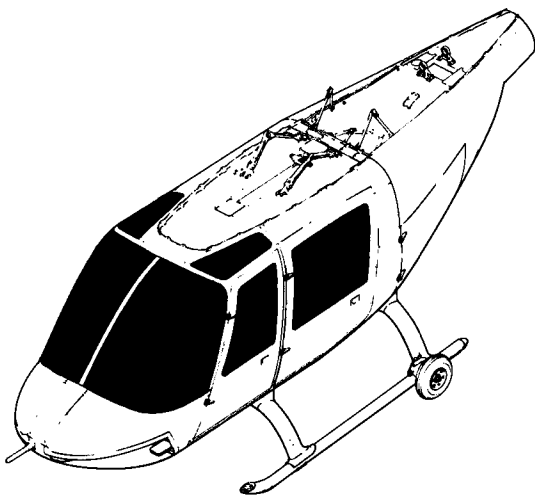

Drain holes with rubber plugs are provided in both chin bubbles to aid in keeping the bubbles clean.

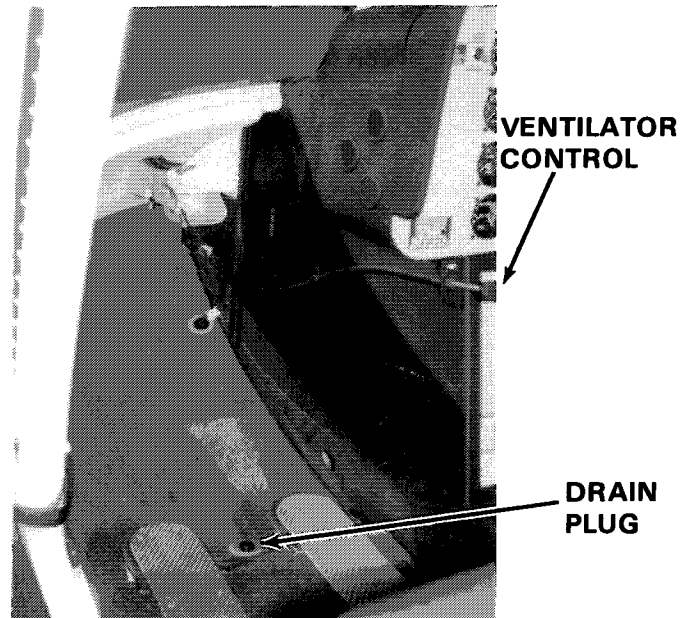

Left Front

021480



THE PILOT'S STATION is on the right.



Observation

014192

Visibility is excellent through the large acrylic windshield, chin bubbles and door windows.

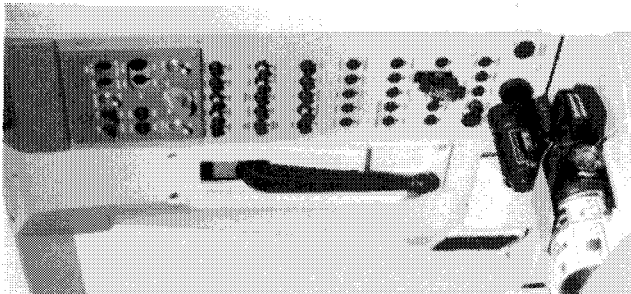

**Overhead Console
Shown with Optional Rotor Brake**

23737

The instrument panel, radio pedestal and overhead console are centrally located: all within easy view and reach.

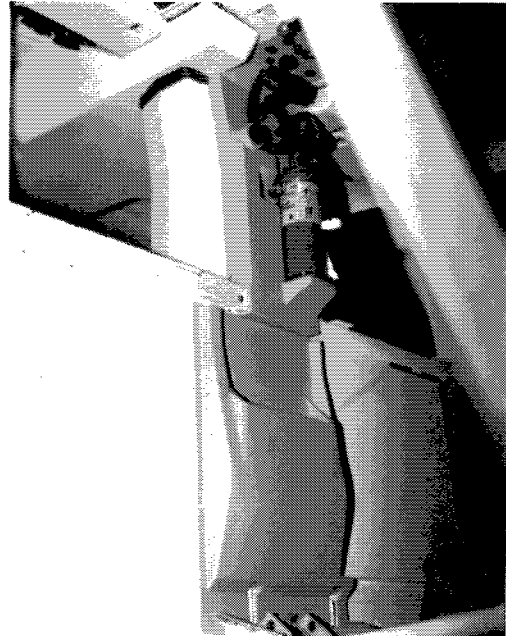

**Vertical Control Tunnel
Shown Without Seats**

310734

A pocket is provided on the right side of the radio pedestal and a document case is built into the trim on the forward face of the vertical control tunnel.



Small, Central Panel

021482M

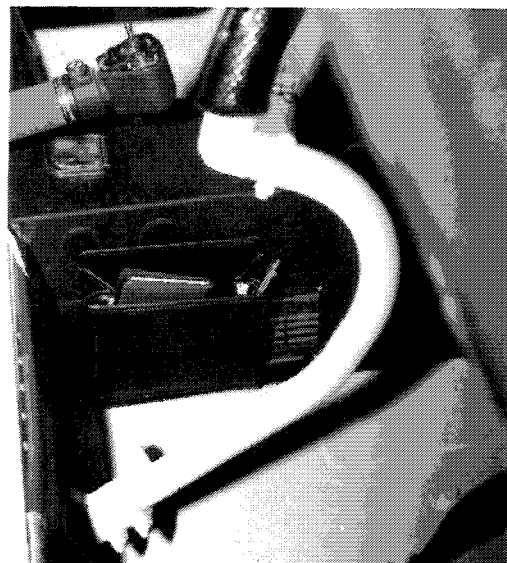

Radio Pedestal Pocket

310740



FLIGHT CONTROLS are conventional. They consist of a cyclic and a collective flight control stick and directional (anti-torque) pedals.

To the pilot, good flying qualities mean quick responsive control, good stability, ease of handling and excellent maneuverability. These qualities are inherent to the JetRanger.

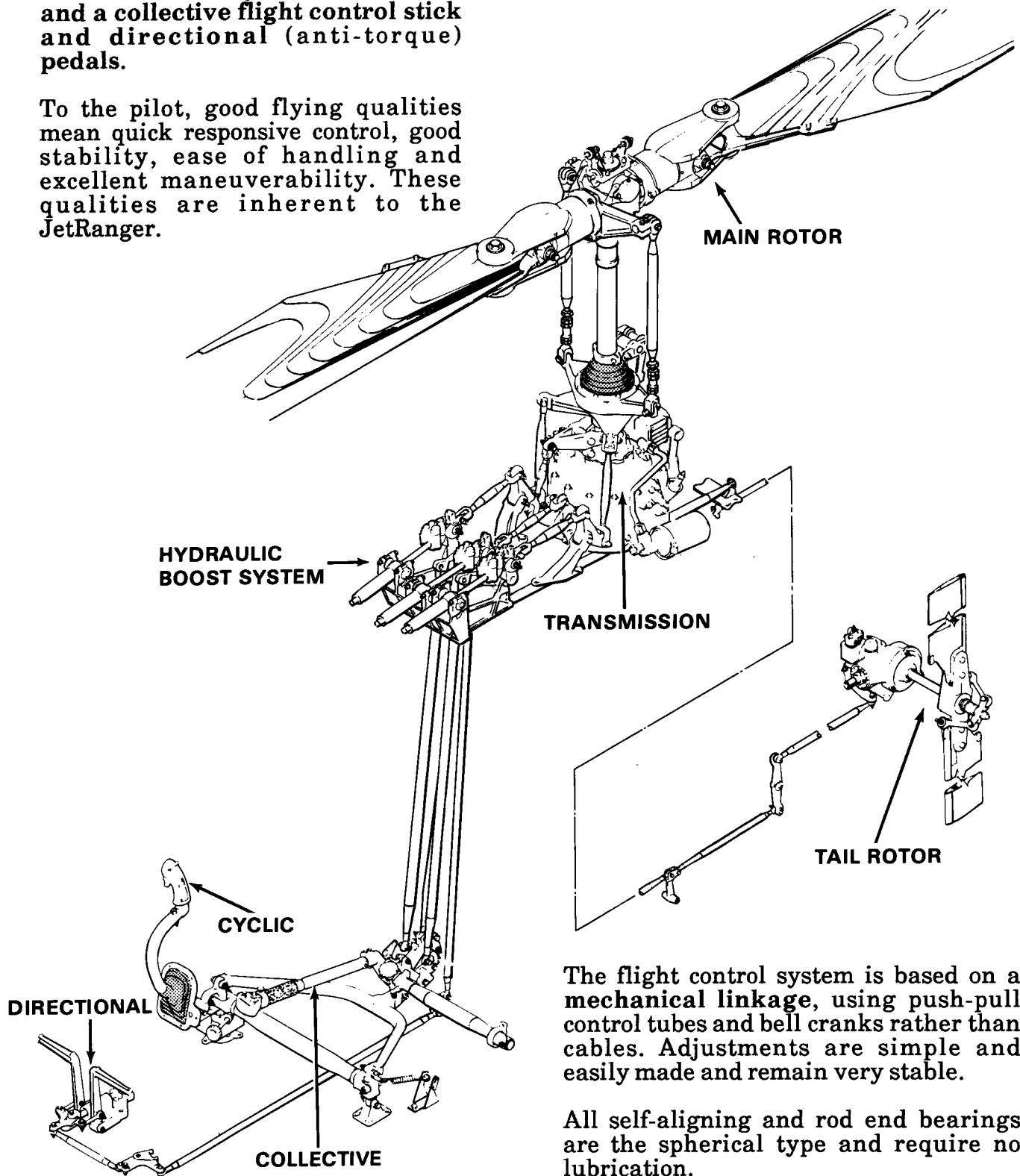

The flight control system is based on a **mechanical linkage**, using push-pull control tubes and bell cranks rather than cables. Adjustments are simple and easily made and remain very stable.

All self-aligning and rod end bearings are the spherical type and require no lubrication.

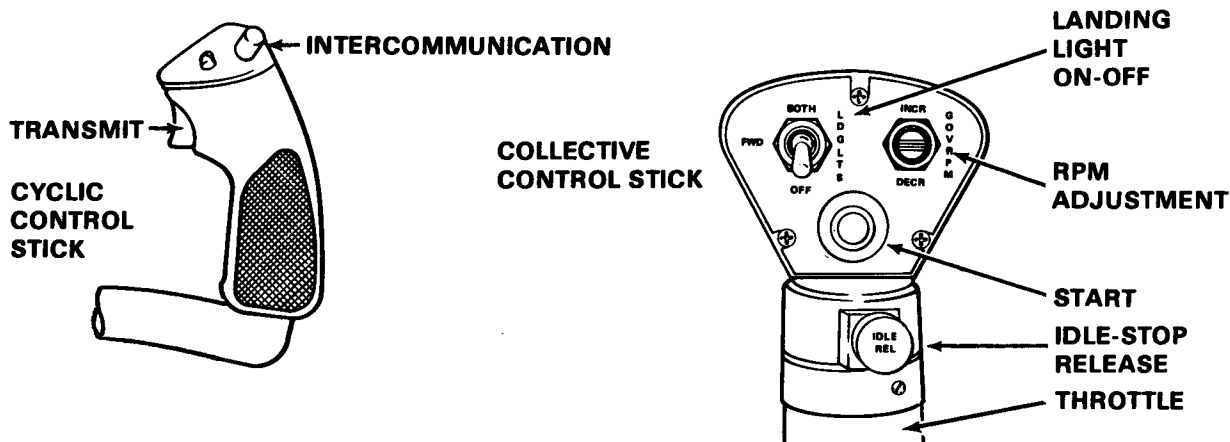

The cyclic control stick provides the JetRanger with fore and aft and lateral control.

The cyclic control stick, centrally located on pivot assembly between the pilot's knees, has a comfortably shaped grip for his right hand. The stick contains a trigger switch for radio transmission and a thumb switch on the top for intercommunication. Force required to move the stick can be adjusted by turning the friction knob located near the base of the stick on the left side.

The **collective control stick** gives the JetRanger up and down movement. The control stick is located at the pilot's left side. It contains the twist grip throttle and terminates in a small control panel. The panel contains the starter button, the RPM adjustment

button and the landing light ON-OFF switch.

A detent prevents the throttle from being inadvertently closed beyond idle. An idle-stop release button mounted on the stick just above the throttle allows the throttle to be fully closed.

Force to move the stick can be adjusted by turning the friction knob which is located at the base of the stick on the left side.

The pilot operates the collective control with his left hand.

Rotor speed control is automatic throughout changes of power (rotor pitch changes). The RPM adjustment button enables the pilot to adjust the rotor speed governor up or down for fine adjustments.



The **directional pedals** control the heading of the JetRanger. These can be adjusted for leg length by turning the knob located between them.

All the control tubes are routed from the controls into the forward seat bench and then up to the roof through the **vertical control tunnel**.

Provisions for the dual controls are included in the system's design.

On reaching the roof, the two rods from the cyclic control and the single one from the collective control are each connected to a hydraulic servo actuator. These **three servo actuators** boost the pilot's input and thus reduce the effort required to fly. They also prevent forces originating in the rotor, such as those created by gusts, from feeding back to the flight controls.



JetRanger III

009440

The servo actuators are mounted on the cabin roof just forward of the transmission. They transmit the boosted cyclic and collective input directly to the swashplate. From there it goes to the main rotor where it is translated into cyclic or collective changes in the pitch of the main rotor blades.

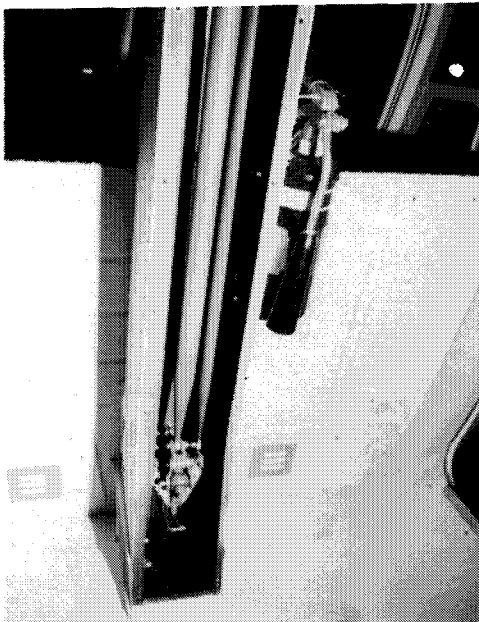

Vertical control Tunnel Open

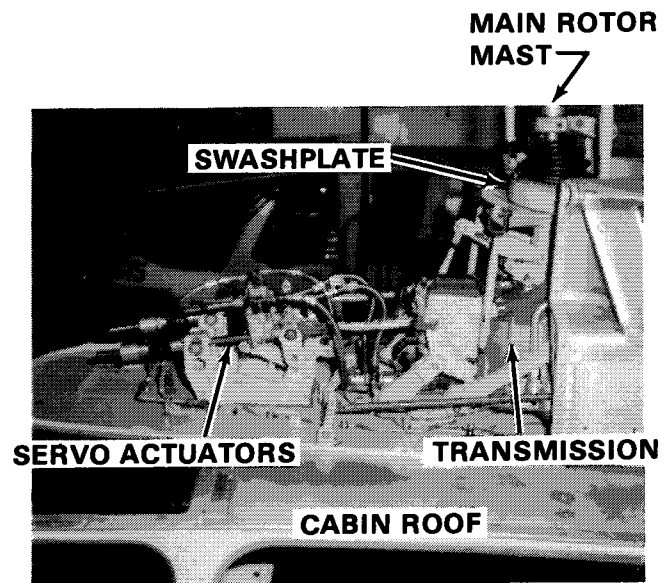

Left side, cowling removed

02279



THIS IS AN UNCONTROLLED DOCUMENT. THE DATA IS PRESENTED FOR GENERAL INFORMATION ONLY. SOME INFORMATION HAS BEEN SUPERCEDED SINCE ORIGINAL PUBLICATION. PLEASE REFER TO THE CURRENT PRODUCT SPECIFICATION BOOKLET FOR UP-TO-DATE STANDARD EQUIPMENT LIST & KIT WEIGHTS, PERFORMANCE, AND DIRECT OPERATING COST.

BELL 206B JETRANGER III



JetRanger III

02279

The swashplate, with its nonrotating inner ring and rotating outer ring, is the interface between the cyclic and collective flight control systems and the main rotor. The swashplate is mounted on a uniball and can be tilted in any direction by control tubes reacting to the cyclic stick input.

Collective inputs are similarly transmitted to the swashplate by raising or lowering it.

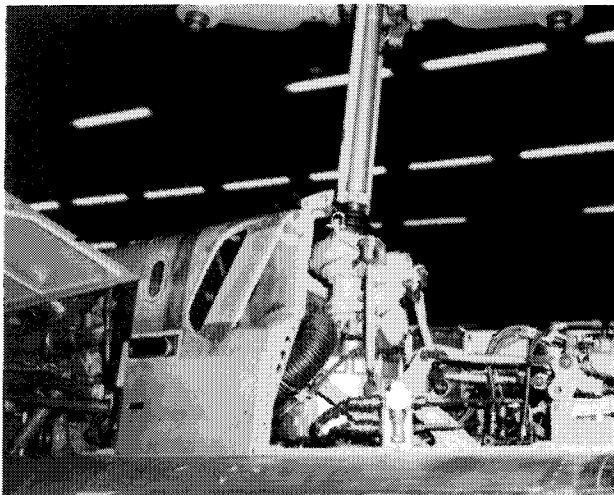

Right side, cowling removed

02279

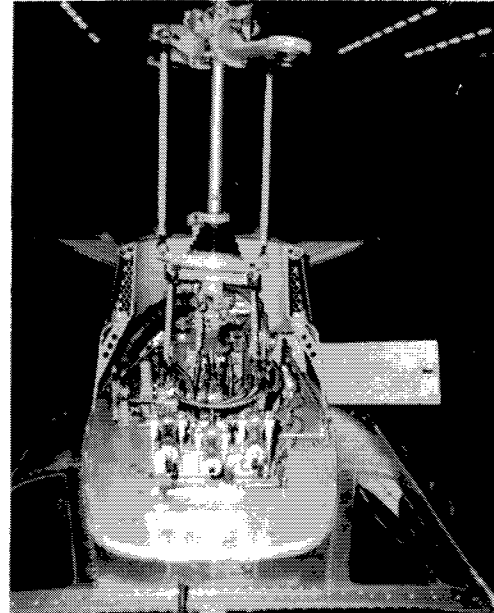

Front View,
Cowling Removed

02279

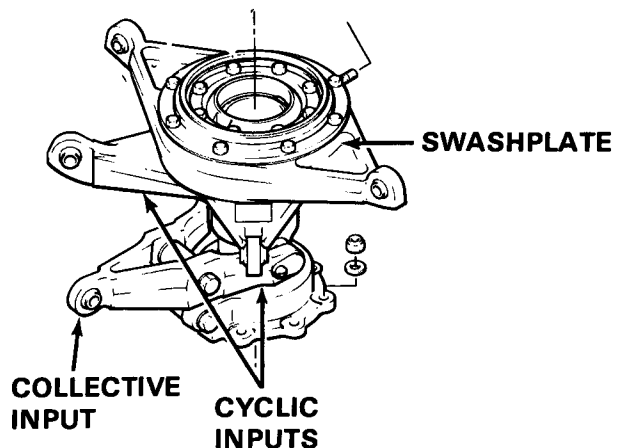
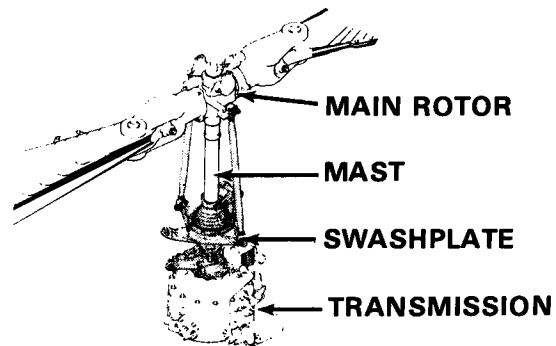



The uniball and the sleeve which allows the vertical movement are both coated with tungsten-carbide to give exceptionally good wear characteristics.

All the inputs to the swashplate are transferred to the main rotor by tubes that connect the swashplate to the pitch horns on the blade grips.

Push-pull action on the pitch horns changes the pitch on the main rotor blades. (See page 1- 52).

UNIBALL AND SLEEVE

UNIBALL AND SLEEVE

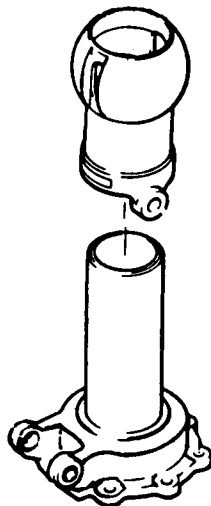

The directional pedal input is not boosted and feedback forces from the tail rotor are so slight that no damping is required. The control rods from the pedals are routed directly back to the tail rotor. The pedals change the pitch of the tail rotor blades collectively to offset the main rotor torque and to provide directional control input to the helicopter.

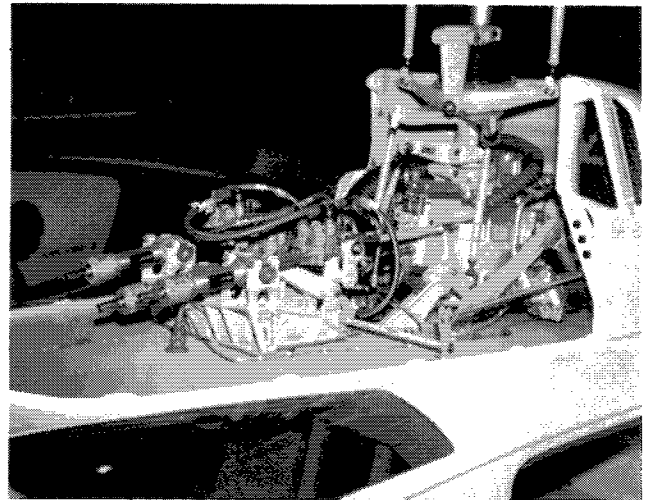

Servo Actuators

02446

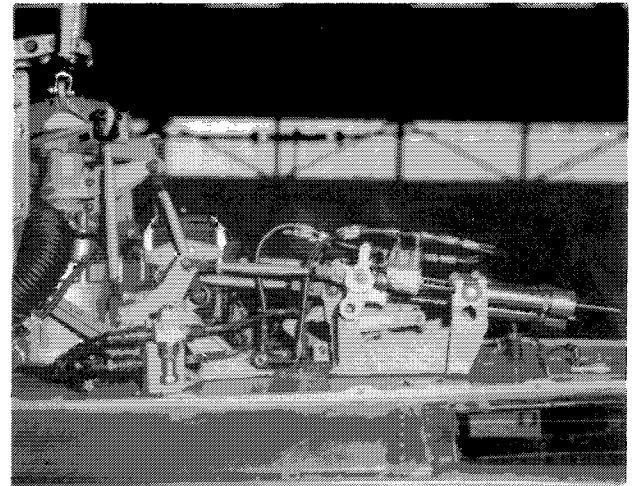

Right Side

02279

THE HYDRAULIC SYSTEM provides the power required by the three servo actuators to boost the flight controls. It has its own pump, reservoir and pressure regulator mounted in one assembly on the front of the transmission.



Because the pump is constantly driven by the transmission, fully boosted flight controls are available during autorotations. Normal operating pressure within the system is 4137 ± 172 kilopascals (600 ± 25 psi).

The reservoir has a capacity of 0.5 liters (1 pint). It has a transparent plastic sight glass to allow a quick visual check of the hydraulic fluid level.

A filter for the system is mounted on the roof, to the right of the pump assembly. The filter element incorporates a "pop-up" red button to warn of a dirty filter and a valve that allows the filter to be bypassed if it becomes clogged.

move the cyclic and collective controls increases. The rate at which they can be changed is slightly decreased. The pilot can isolate the system by turning it off. He can continue the flight regardless of the duration because the feedback through his controls is not excessive. For this reason a back-up system is not required.

Normal maintenance consists of maintaining the system at the correct fluid level. Quick disconnects provide a simple means of using a hydraulic test stand during major inspections.

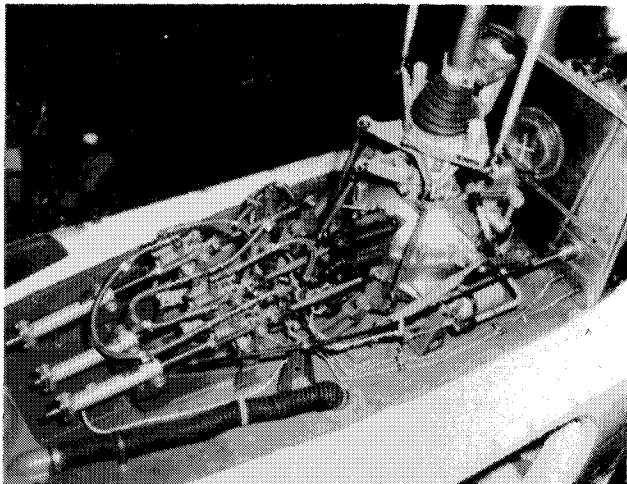

Servo Actuators

257055

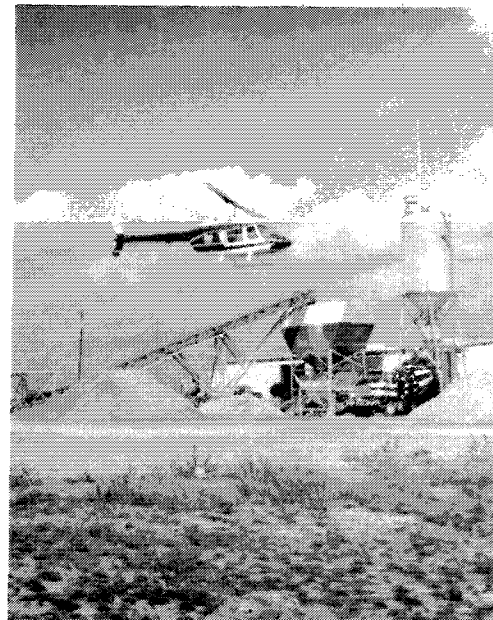

014988

Just forward of the pump assembly is a solenoid valve which permits or prevents the flow of fluid in the system depending on the selected position. It is electrically operated by a switch on the radio pedestal.

If a hydraulic malfunction occurs, the flight control motions remain the same but the force required to



THIS IS AN UNCONTROLLED DOCUMENT. THE DATA IS PRESENTED FOR GENERAL INFORMATION ONLY. SOME INFORMATION HAS BEEN SUPERCEDED SINCE ORIGINAL PUBLICATION. PLEASE REFER TO THE CURRENT PRODUCT SPECIFICATION BOOKLET FOR UP-TO-DATE STANDARD EQUIPMENT LIST & KIT WEIGHTS, PERFORMANCE, AND DIRECT OPERATING COST.

BELL 206B JETRANGER III

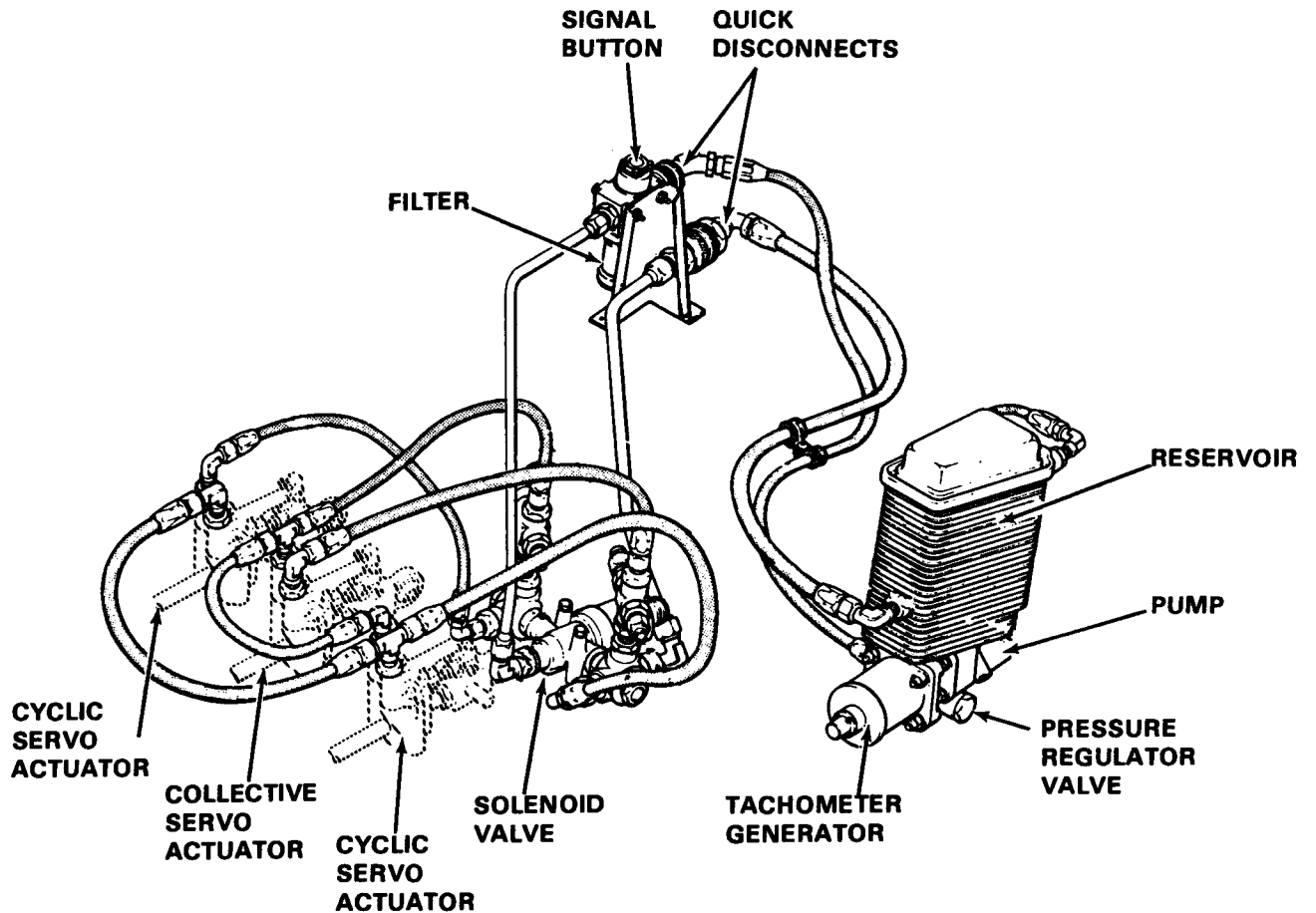

Hydraulic System

With this system good control qualities have been achieved. The JetRanger has light, precise control and there is no feedback through the controls even in turbulent air.

All the components of the flight control system are readily accessible.

The system is easily rigged and requires very little maintenance to keep it perfectly aligned.



THIS IS AN UNCONTROLLED DOCUMENT. THE DATA IS PRESENTED FOR GENERAL INFORMATION ONLY. SOME INFORMATION HAS BEEN SUPERCEDED SINCE ORIGINAL PUBLICATION. PLEASE REFER TO THE CURRENT PRODUCT SPECIFICATION BOOKLET FOR UP-TO-DATE STANDARD EQUIPMENT LIST & KIT WEIGHTS, PERFORMANCE, AND DIRECT OPERATING COST.

BELL 206B JETRANGER III



Standard Instrument Panel

012844M

THE INSTRUMENT PANEL in the standard JetRanger has the basic flight and engine instruments with ample space to add a wide selection of options. Visibility forward and to the side is excellent due to the panel's low, compact design. A magnetic compass is mounted on the fuselage to the right of the panel and an outside-air temperature gauge indicating both degrees Celsius and degrees Fahrenheit is mounted on the upper right windshield near the center post.

The panel has a shield to reduce glare and vents on both sides to permit air circulation. The panel is hinged along the bottom edge so that the whole compartment can easily be opened for inspection or maintenance.

Integral white instrument lighting can be controlled by a dimming switch in the overhead console.

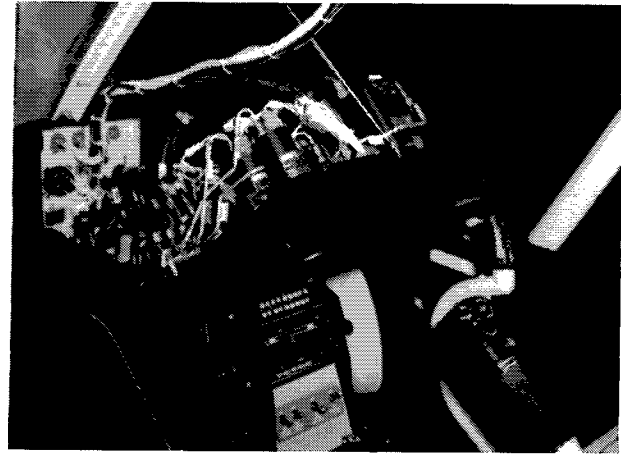

Hinged Panel
(Glare Shield Removed)

02279

The pitot tube is mounted externally on the forward part of the nose section. Two static ports are mounted one on each side of the fuselage just forward of the crew doors.

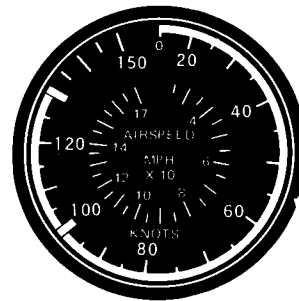

AIRSPPEED
INDICATOR

The airspeed indicator is a standard 7.6 cm (3 inches) instrument indicating in knots and miles per hour.



THIS IS AN UNCONTROLLED DOCUMENT. THE DATA IS PRESENTED FOR GENERAL INFORMATION ONLY. SOME INFORMATION HAS BEEN SUPERCEDED SINCE ORIGINAL PUBLICATION. PLEASE REFER TO THE CURRENT PRODUCT SPECIFICATION BOOKLET FOR UP-TO-DATE STANDARD EQUIPMENT LIST & KIT WEIGHTS, PERFORMANCE, AND DIRECT OPERATING COST.

BELL 206B JETRANGER III

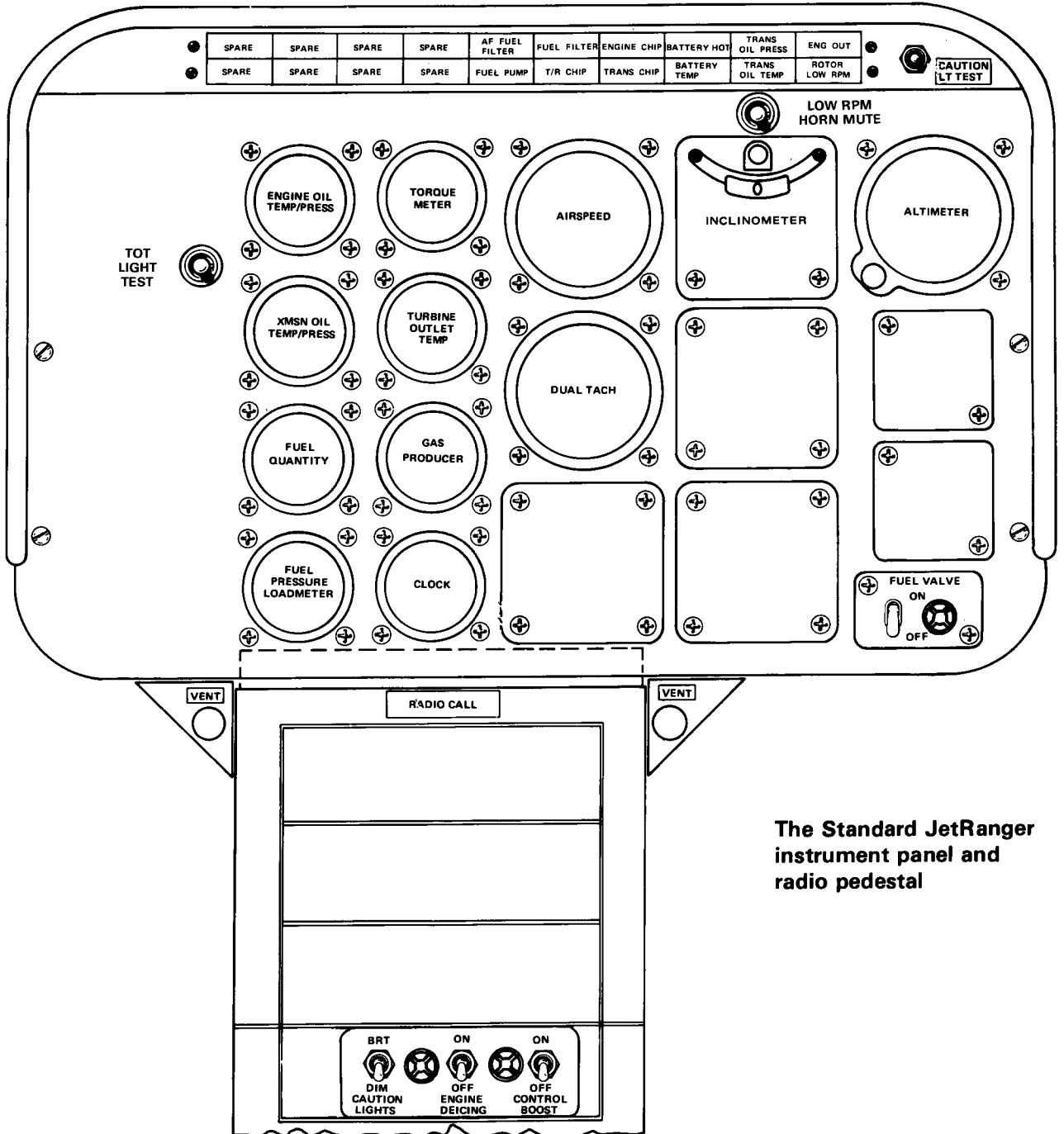

The Standard JetRanger instrument panel and radio pedestal



The inclinometer is a curved glass tube and ball indicating level flight and coordinated turns.

The altimeter is a static air-vented system indicating altitude from minus 1000 to plus 20,000 feet. It is calibrated in inches of mercury and is 7.6 cm (3 inches) in size.

The 8-day clock shows the time. It has a sweep-second pointer.

The fuel quantity gauge indicates in U.S. gallons.

The fuel pressure and loadmeter gauge indicates the fuel pressure to the engine in pounds per square inch and the electrical load on the dc generator.

Space saving in the panel is obtained by using small engine and transmission gauges, by combining instruments, and by substituting caution lights for gauges.

The engine instruments are as follows:

Dual tachometer	Indicates engine power turbine rpm and main rotor rpm (in percentage of power turbine and rotor rpm).
Torquemeter	A wet-line type indicator displays torque output of engine in percentage of maximum allowable torque.
Transmission oil pressure and temperature	A wet-line type dual indicator indicates pressure (psig) and temperature (°C) of transmission oil.
Engine oil pressure	A wet-line type dual indicator indicates engine oil pressure and and temperature (psig) and temperature (°C).
Gas producer tachometer	Indicates gas producer speed in percentage of rpm.
Turbine outlet temperature (TOT)	A servo type with an expanded scale. It indicates the turbine outlet temperature in degrees Celsius sensed by thermocouples mounted at the gas producer turbine outlet of the engine. The needle goes to zero when power is shut off. A red warning light is incorporated on the face of the TOT indicator. It will illuminate if the red line temperature of 810 to 927 degrees is exceeded for 10 seconds; 927 degree or higher for 1 second. It will remain illuminated until power is removed or the circuit is reset by the technician. If not reset, the light will come on any time power is applied. The TOTLT TEST button is to aid in the adjustment of the temperature that activates the light, and provides assurance that the sensing circuit is functional.



THIS IS AN UNCONTROLLED DOCUMENT. THE DATA IS PRESENTED FOR GENERAL INFORMATION ONLY. SOME INFORMATION HAS BEEN SUPERCEDED SINCE ORIGINAL PUBLICATION. PLEASE REFER TO THE CURRENT PRODUCT SPECIFICATION BOOKLET FOR UP-TO-DATE STANDARD EQUIPMENT LIST & KIT WEIGHTS, PERFORMANCE, AND DIRECT OPERATING COST.

BELL 206B JETRANGER III

CAUTION PANEL

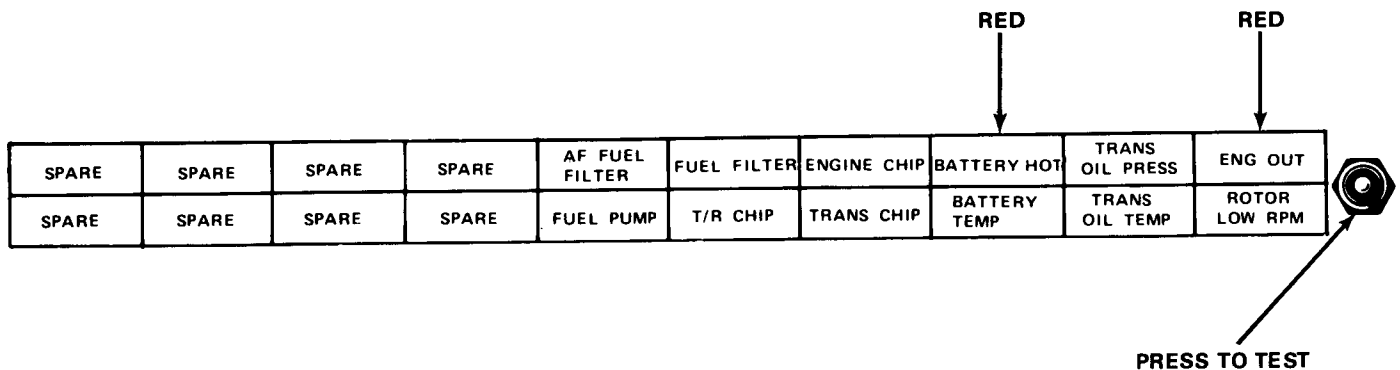

The caution panel is located across the top of the instrument panel. It contains 20 modules, each containing a light which illuminates individually when a fault occurs.

The light intensity of all but the ENG OUT and ROTOR LOW RPM indicators can be controlled by means of a DIM/BRIGHT switch on the radio pedestal and a rheostat in the roof panel. The rheostat adjusts the intensity of all instrument lighting, but affects the caution lights only if the DIM/BRIGHT switch is on DIM. A reset capability ensures that the DIM/BRIGHT switch will automatically be set to BRIGHT each time the electrical power is turned on.

The lights are tested by depressing one test button at the right end of the caution panel.

Bulb replacement is simplified by rocker-type holders that swing out to expose the bulb.

Capsules shown as spares are available for optional kits.

The lighting is amber except where otherwise stated.



The caution panel indications are as follows:

AF FUEL FILTER	The airframe-mounted fuel filter is about to be bypassed.
ENGINE CHIP	Metal particles are on the engine chip detector.
BATTERY HOT	The battery temperature is excessively high, approximately 60°C (140°F).
TRANS Oil PRESS	The transmission oil pressure is too low.
ENG OUT	The rpm of the gas producer tachometer is too low. A pulsating audio signal is also energized.
FUEL PUMP	A malfunction has occurred in one of the boost pumps or pressure switches.
TR Chip	Metal particles are on the tail rotor chip detector.
TRANS CHIP	Metal particles are on the transmission chip detectors.
BATTERY TEMP	The battery temperature is above normal, approximately 54°C (130°F),
TRANS OIL TEMP	The transmission oil temperature is too high.
ROTOR LOW RPM	The rotor rpm is below a preset level. A steady audio signal is also energized.



THE OVERHEAD CONSOLE
contains:

- Two headset outlets.
- Two warning horns:
-pulsating for engine out
-steady for low rotor rpm
- Breakers for all the electrical circuits.
- Switches for interior and exterior lights, defog blowers, battery and generator.
- Spaces are provided for circuit breakers and switches for optional kits.

An airspeed limit placard is located at the forward edge.

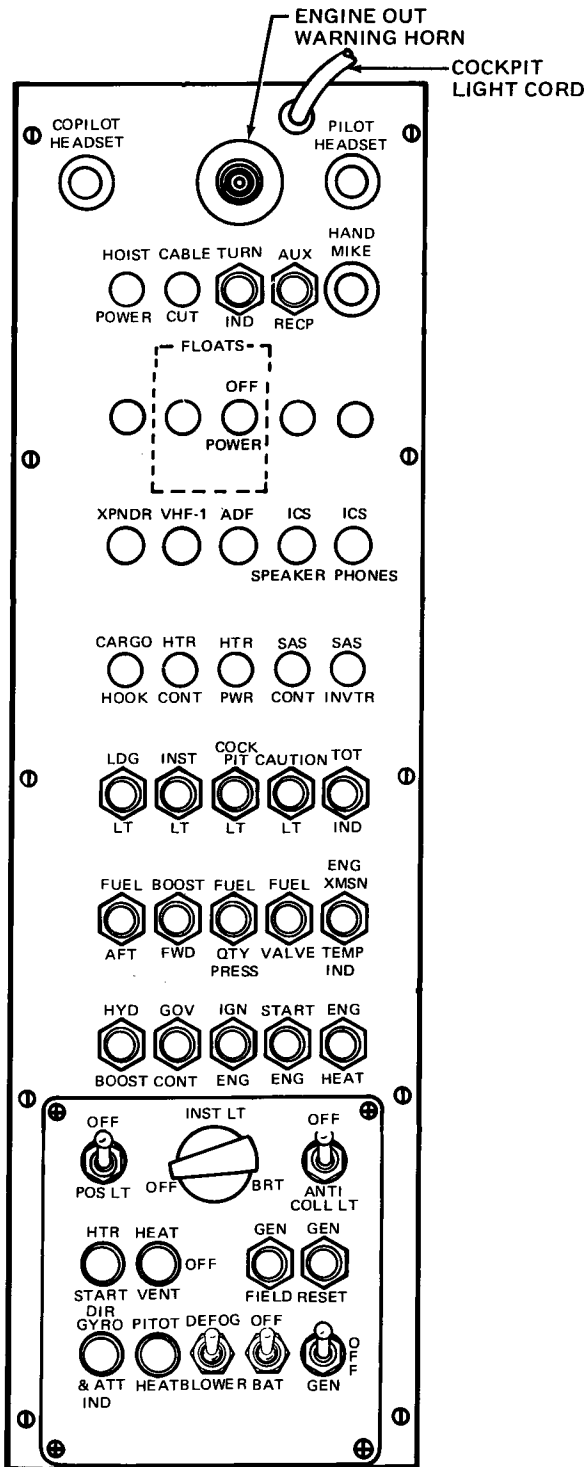

Overhead Console



THE RADIO PEDESTAL slopes from the instrument panel and extends horizontally to the seat bench to give the pilot the best viewing angle of the radio controls.

It can accept the standard width radio boxes in both the sloping and horizontal surfaces. (159 cm or 6.25 inches in width.)

The pedestal also includes the miscellaneous switching panel for:

- caution-light dimming
- engine anti-ice
- control boost

Space is also provided for an **OPTIONAL Ash Tray Kit**.

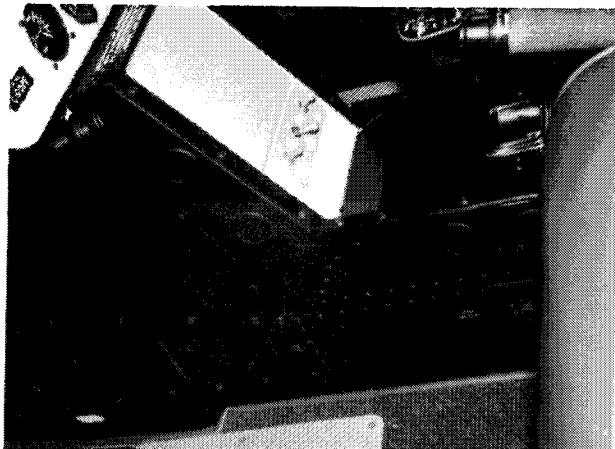

Radio Pedestal

02272

A portable fire extinguisher and a utility light are mounted on the vertical control tunnel.

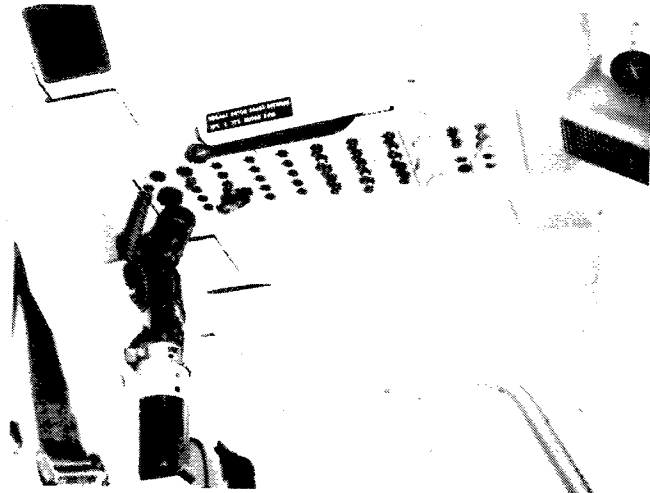

Fire Extinguisher and Utility Light Shown with Optional Rotor Brake and Speakers

23723

THE AIRFRAME

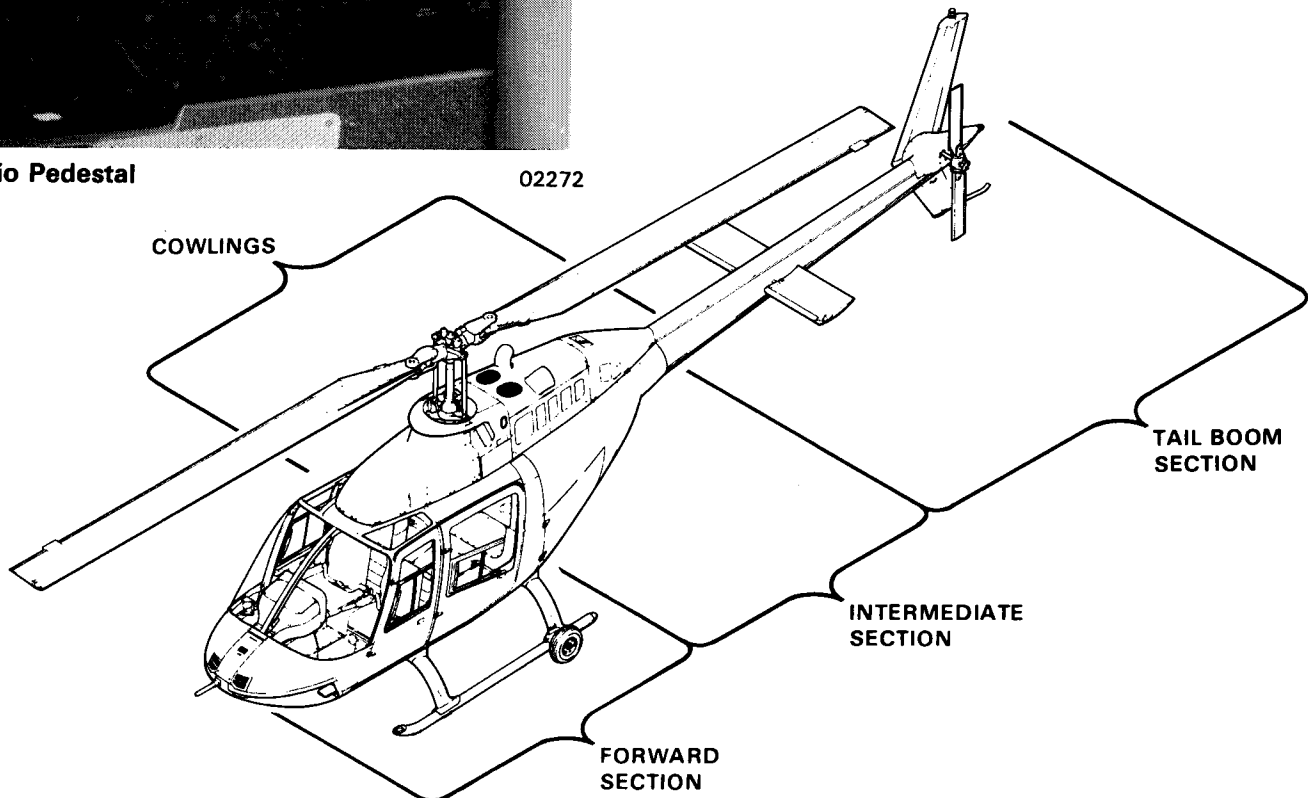



THIS IS AN UNCONTROLLED DOCUMENT. THE DATA IS PRESENTED FOR GENERAL INFORMATION ONLY. SOME INFORMATION HAS BEEN SUPERCEDED SINCE ORIGINAL PUBLICATION. PLEASE REFER TO THE CURRENT PRODUCT SPECIFICATION BOOKLET FOR UP-TO-DATE STANDARD EQUIPMENT LIST & KIT WEIGHTS, PERFORMANCE, AND DIRECT OPERATING COST.

BELL 206B JETRANGER III

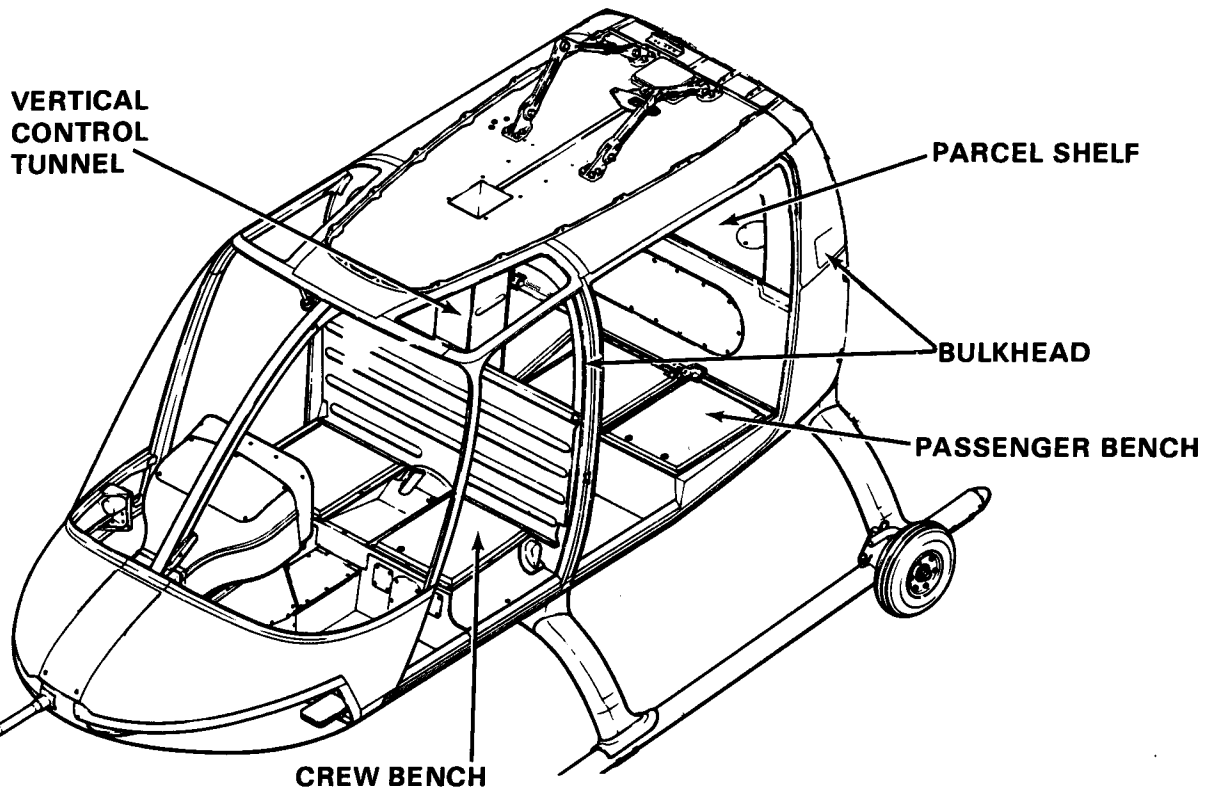

THE FUSELAGE consists of four main sections; the **forward section** which extends from the cabin nose to the bulkhead aft of the passenger compartment, the **intermediate section** which extends from the bulkhead aft of the passenger compartment to the tail boom, the **tail boom section** and the **cowlings**.

The **forward section** of the fuselage includes the crew and passenger compartments which together make up the cabin.

It is basically an aluminum honeycomb structure using one-inch thick honeycomb and a combination of fiberglass and sheet metal facings.

Both the crew and passenger seat benches, of aluminum honeycomb, are a major part of the structure. The latter forms the fuel cell enclosure

with the space above forming a parcel shelf. The top surface of the front bench has been "dished-out" to provide maximum headroom for the two seats.



Crew Seats Construction

310744



Two rugged bulkheads are built into the cabin, one behind each of the seat benches. A vertical control tunnel is fitted from floor to roof immediately behind the forward bulkhead. These all add structural integrity to the cabin and provide roll over protection to the occupants.

A pair of longitudinal beams in the cabin roof give additional strength for the support of the transmission.

The nose section is an extension of the crew compartment. The honeycomb deck supports the instrument panel and radio pedestal.

The structure extends up to the windshields, forming compartments for the landing lights and the battery. The power receptacle and pitot tube are mounted externally between the two compartments.

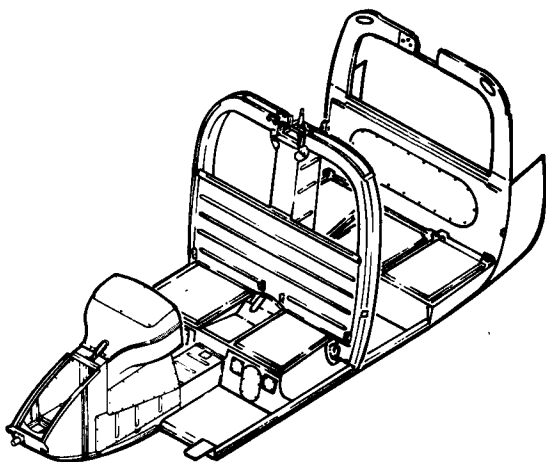

The honeycomb cabin structure provides a rugged, live-in-the-field durability. Its strength-to-weight ratio is superior to conventional aircraft construction techniques and it affords high impact strength as a result of a combination of multiple load paths and structural rigidity.

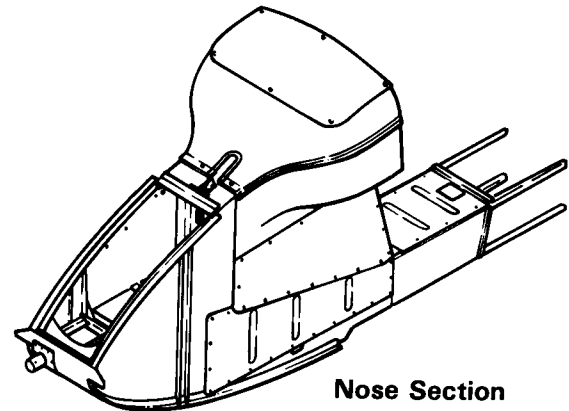

Nose Section

The structure is easy to repair. It has the best inside dimensions for the most compact external size and it has attractive curved surfaces that are difficult to achieve with the more conventional methods.

Ventilation is provided by windows in the crew and passenger compartments and by a ram-air/defog system installed in the upper nose section. During flight, ram-air enters through two large grilles located in the nose. Two separate subsystems, one connected to each grille, direct the air to the windshields. Each has its own nozzle curved to fit the windshield contour and each has its own air volume control. The control knobs are mounted one on each side of the radio pedestal just below the instrument panel. The volume of air entering either or both subsystems is increased by pulling on one or both control knobs which lock automatically whenever they are released. To decrease the volume the release button in the center of the control knob must be pressed and the knob pushed forward.

When on the ground, ample flow of air for defogging is provided by electric blowers, one in each system. The Defog Blower switch to activate them is mounted on the overhead console.

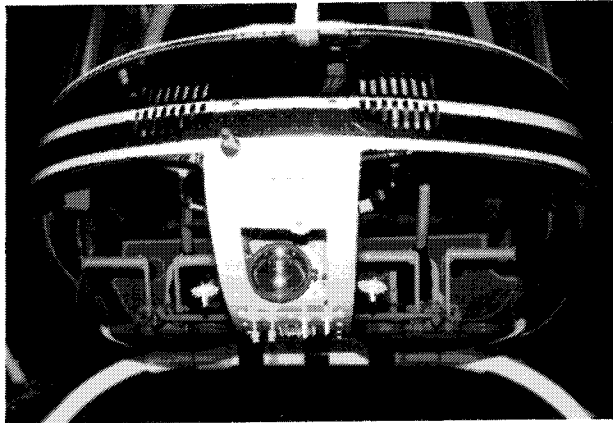

Ventilation Grilles

02272

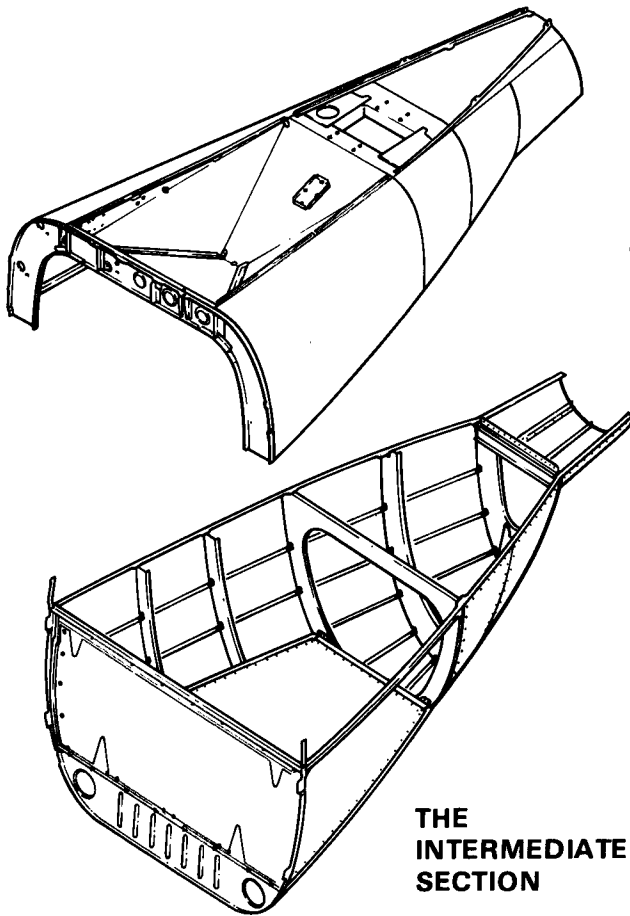

**THE
INTERMEDIATE
SECTION**

The intermediate section is a semi-monocoque structure that provides an engine deck, a baggage compartment and an equipment compartment.

It is enclosed by aluminum-alloy skins and a fiberglass fairing at the lower aft end.

The titanium engine pan and firewalls are fitted to the top of the intermediate section to form an engine compartment

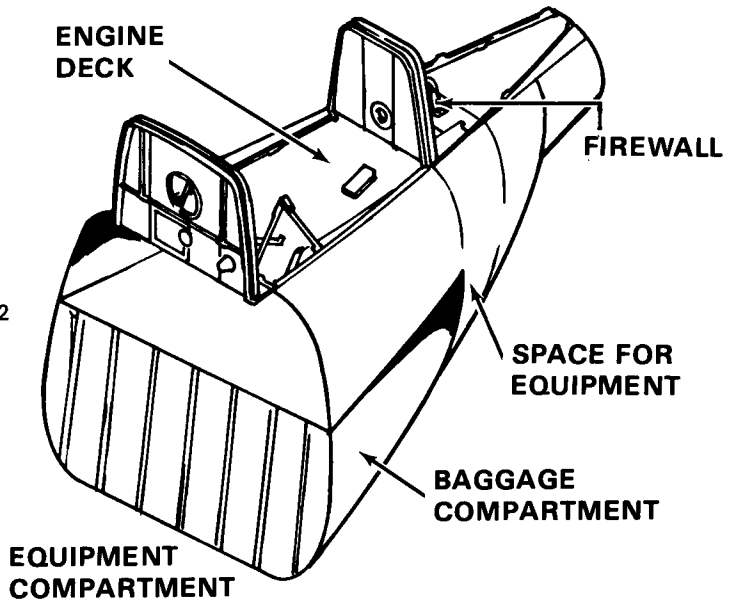

Convenient Baggage Compartment

The baggage compartment is located in the intermediate section. It has a volume of 0.45 cubic meters (16 ft³) and can carry a load of 113.4 kilograms (250 lb). The door is on the left side and opens the full width and height of the compartment. It is hinged at the forward end and secured by two push button latches and a keyed lock -- the same key as for the doors.

Ten tie-down loops are provided.

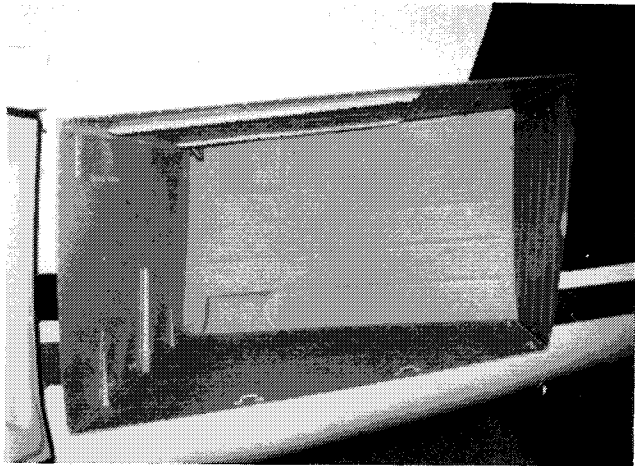

Tie-downs

02247

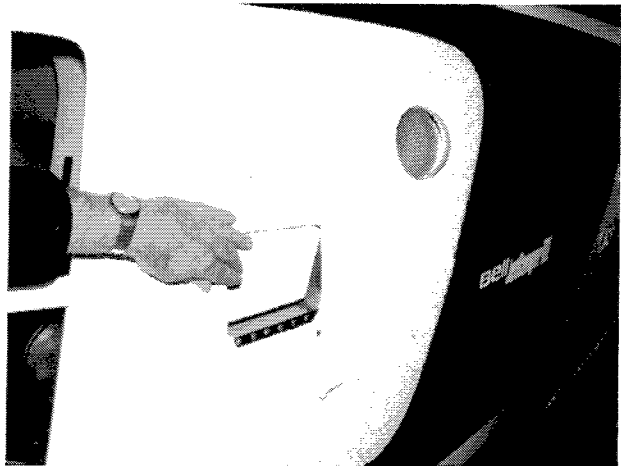

Kick-In Step

02272

A kick-in step is provided aft of the left passenger door for access to the roof.

The equipment compartment is an area immediately behind the parcel shelf and above the baggage compartment.

It contains the electrical relays and regulators and has space for the optional heater or environmental control unit -- a convenient location near the source of bleed air.

There is space for additional equipment immediately behind the baggage compartment. Selected items can be installed there without interfering with the baggage area.

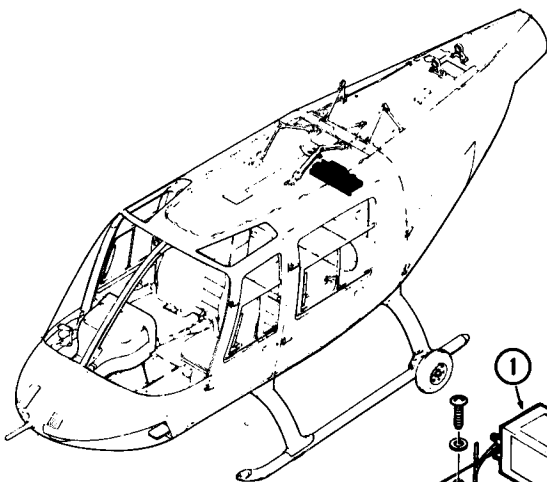

The Equipment Compartment

1. Over voltage relay
2. Generator field relay
3. Load meter shunt
4. Generator field reset
5. Starter relay
6. Load meter circuit breakers
7. Reverse current relay
8. Voltage regulator
9. Base — voltage regulator

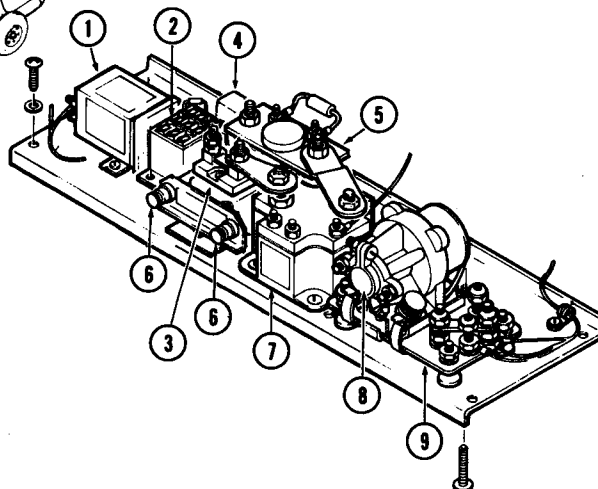



The transmission and the engine are mounted on the fuselage roof, easily accessible, well clear of the passenger cabin and as far as possible from the fuel cell.

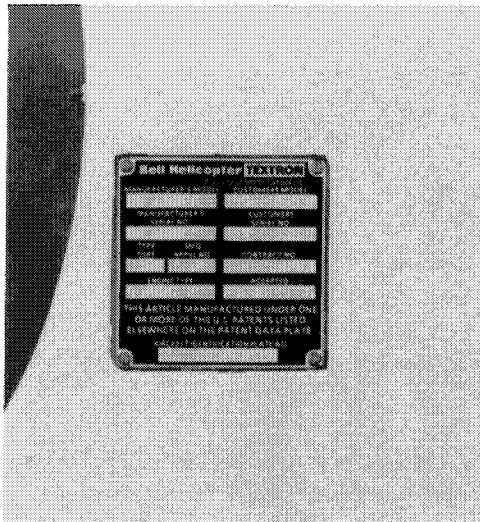
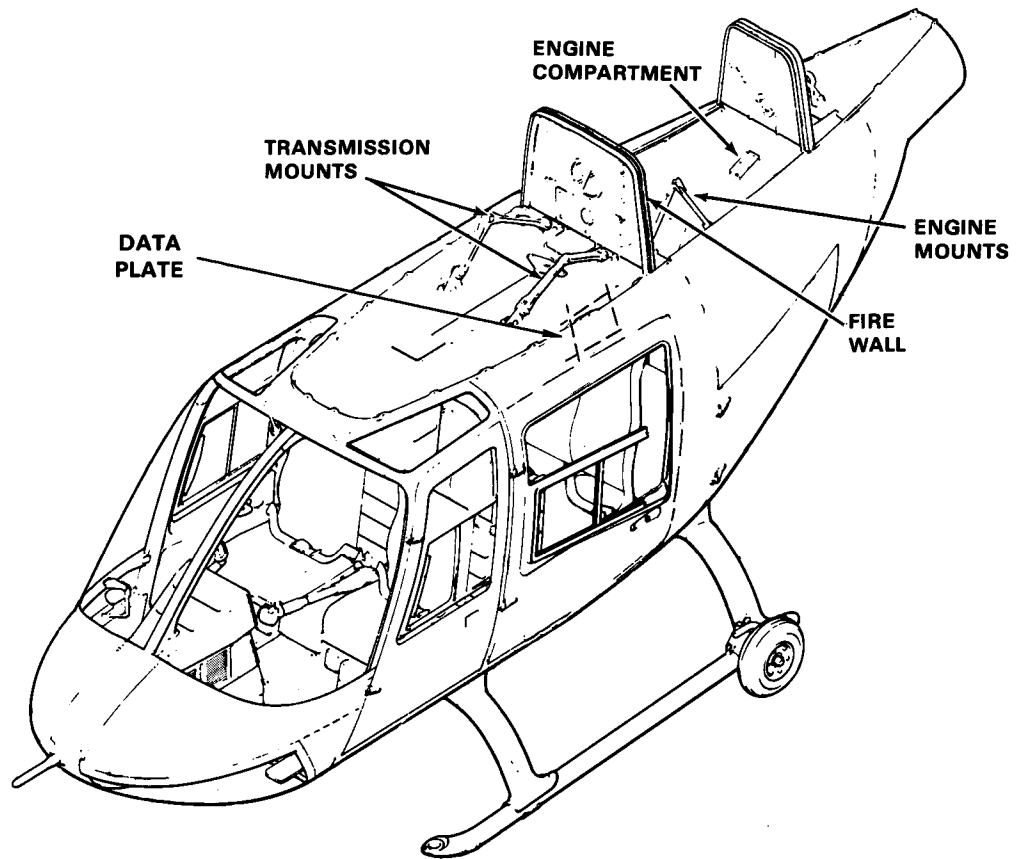

The manufacturer's data plate is located on the right side of the intermediate section near the fuel filler cap.



THE TAIL BOOM is an aluminum-alloy monocoque structure that supports the tail fin, the fixed horizontal stabilizer, the tail rotor, and the tail rotor drive train.

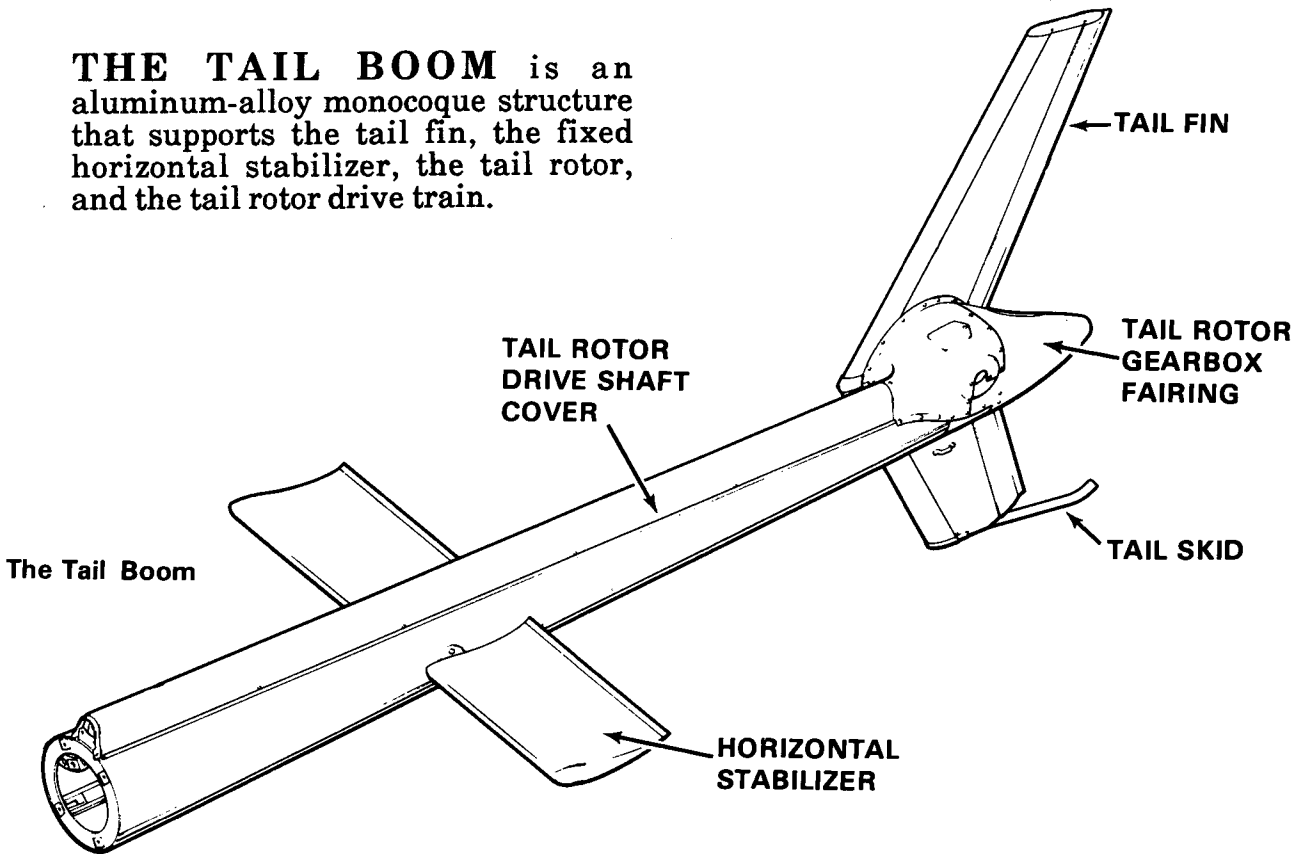

The tail fin provides directional stability. It sweeps back, both above and below the end of the tail boom on the right side. The leading edge is canted outboard to reduce tail rotor thrust requirements during forward flight.

A tubular steel tail skid attached to the bottom of the fin acts as a bumper to protect the fin and tail rotor in the event of a tail-low landing.

The horizontal stabilizer maintains a near level fuselage trim throughout the full speed range.

An easily removable aluminum-alloy cover that extends along the top of the tail boom protects the tail-rotor drive-shaft train from the elements. A fairing made of sheet metal incorporates either an acrylic window or a screened area for viewing the oil level sight gauge.



JetRanger III

02279

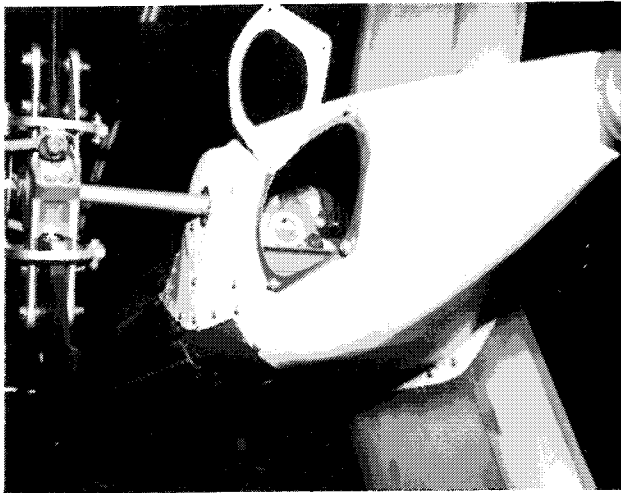

Window in the Gear Box Fairing

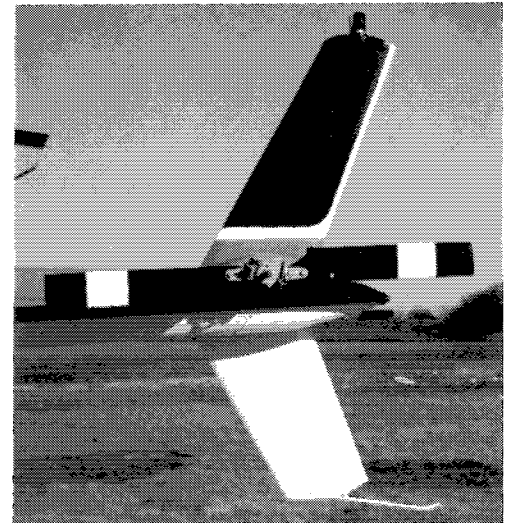

Tail Skid

02279

THE COWLINGS AND FAIRINGS

All components mounted on the JetRanger roof are protected from the elements by aerodynamically shaped cowlings and fairings.

The engine cowling has a full length hinged door on each side, each with a rod to keep the door in the raised position.

The Cowlings

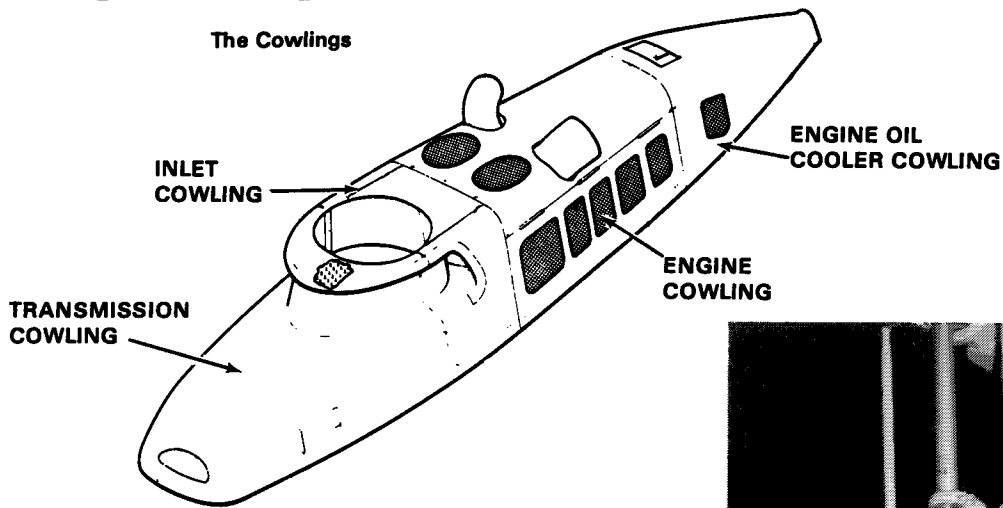

02279



The other cowlings have hinged doors for access to components requiring inspection and servicing.

No tools are required to open any of the doors.

Ports in the cowlings allow quick inspection of oil levels. The cowlings are individually removable.

The transmission cowling has standard provisions for optional snow deflectors.

LANDING GEAR for the JetRanger III is the tubular skid type made of aluminum alloy. Each of the two arched cross tubes is attached to the fuselage with two caps. This allows the gear to be attached or removed easily so that alternate types of landing gear may be installed.

The skid landing gear is simple, rugged, and practically maintenance free. It is designed to absorb energy and to preclude extensive damage to the helicopter in the event of a hard or high-impact landing. It is stressed for landings up to 2.4 meters per second, (7.9 feet per second).



Wide Stance

02279



Built for rugged service

309000

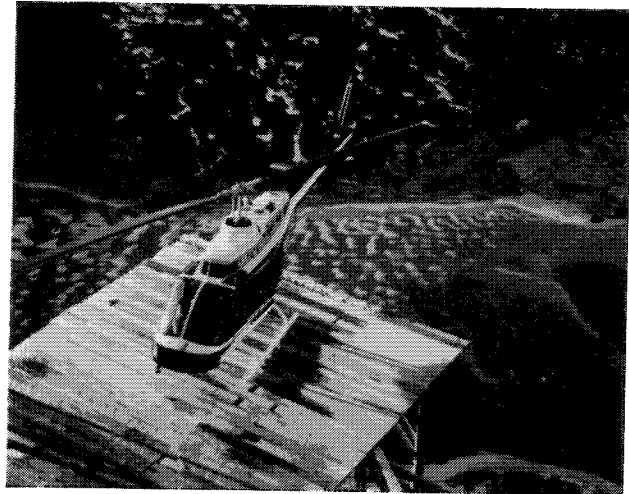

Simple Landing Gear

At normal vertical ground-contact speeds, the gear will "springback" after touchdown. At excessive vertical speeds, up to 3 meters per second (10 feet per second), the gear will "yield" (taking on a permanent deformation) and absorb additional energy to avoid damage to the helicopter.

It is particularly adept for landing on rough, uneven surfaces.

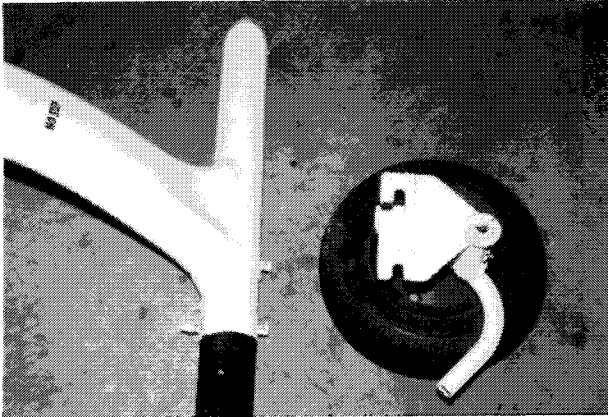

Ground Handling Wheel

02272

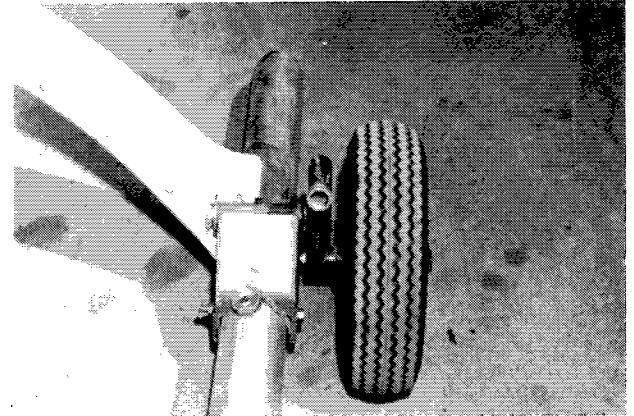

Wheel in position

282103

The skid tubes have fittings for the ground handling wheels. To move the JetRanger on the ground the wheels are snapped and pinned in place at the rear of each skid near the center of gravity. The wheels are extended or retracted manually using a lift bar and a cam mechanism. Once in the raised position the wheel is locked in place with a pin. The wheels must be removed for flight. Two tow rings are supplied as loose equipment. One is mounted on the toe of each skid.

Each skid is fitted with five replaceable skid shoes to absorb the wear caused by normal ground contact.

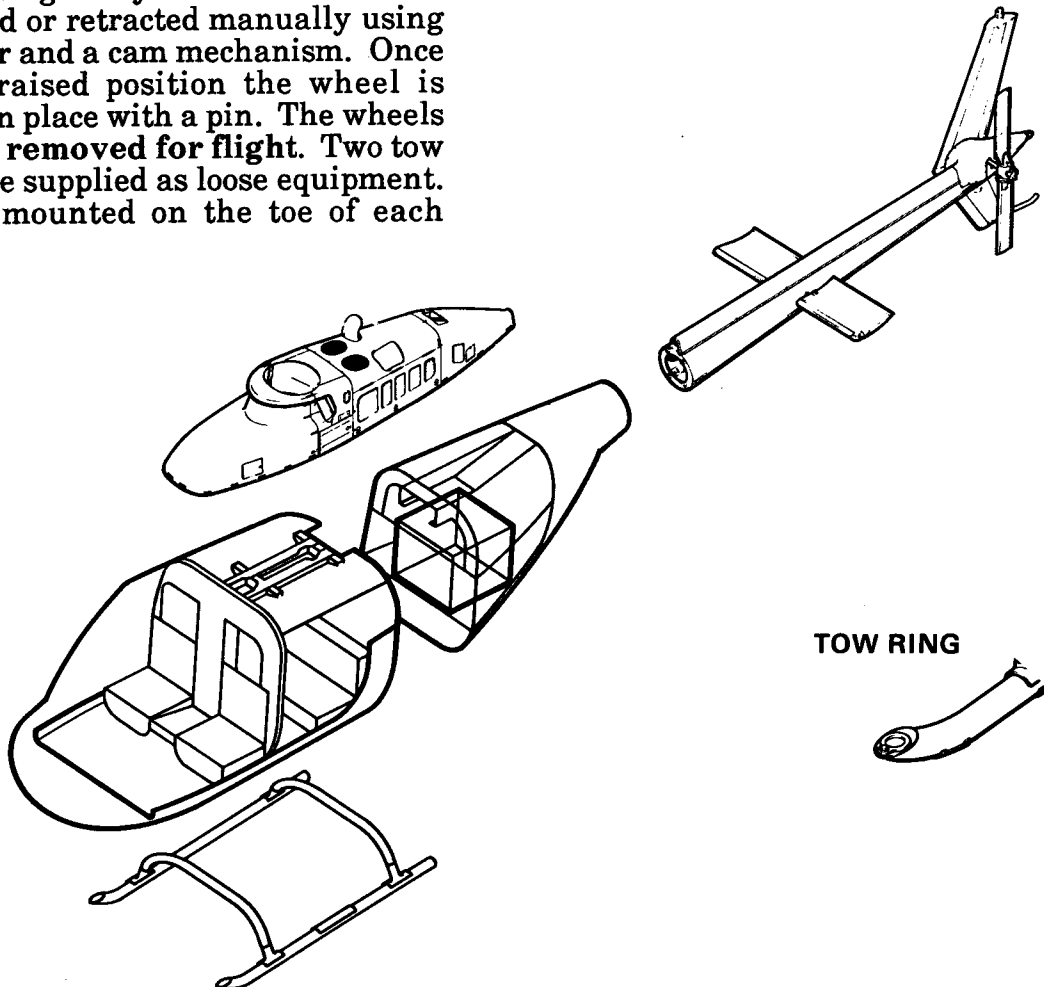

TOW RING



THIS IS AN UNCONTROLLED DOCUMENT. THE DATA IS PRESENTED FOR GENERAL INFORMATION ONLY. SOME INFORMATION HAS BEEN SUPERCEDED SINCE ORIGINAL PUBLICATION. PLEASE REFER TO THE CURRENT PRODUCT SPECIFICATION BOOKLET FOR UP-TO-DATE STANDARD EQUIPMENT LIST & KIT WEIGHTS, PERFORMANCE, AND DIRECT OPERATING COST.

BELL 206B JETRANGER III



All areas where moisture may collect have **drain holes**.

Three **tie down fittings** are provided. These are also used as **jacking points**.

The complete JetRanger can be **hoisted** from a single point--the **main mast nut**.

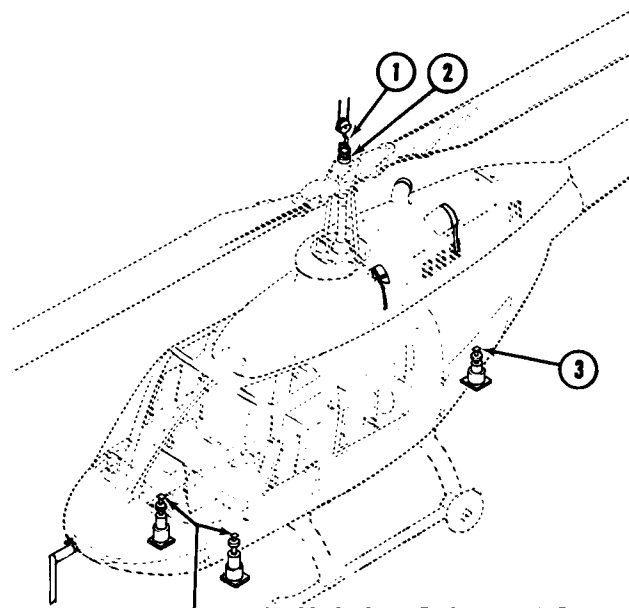

1. Hoisting Cable and Clevis
2. Main Rotor Mast Nut
3. Jack and Mooring Points

THIS IS AN UNCONTROLLED DOCUMENT. THE DATA IS PRESENTED FOR GENERAL INFORMATION ONLY. SOME INFORMATION HAS BEEN SUPERCEDED SINCE ORIGINAL PUBLICATION. PLEASE REFER TO THE CURRENT PRODUCT SPECIFICATION BOOKLET FOR UP-TO-DATE STANDARD EQUIPMENT LIST & KIT WEIGHTS, PERFORMANCE, AND DIRECT OPERATING COST.

PUBLISHERS NOTICE

The data presented in this document is **GENERAL** in nature, and has been compiled from Bell Helicopter Textron Inc. [**BHTI**] publications including but not limited to; The Model 206B3 Rotorcraft Flight Manual & Manufacturers Data, The Model 206B3 Maintenance Manual, The Model 206B3 Illustrated Parts Catalog, and **BHTI** Training Academy Model 206B3 Pilot and Mechanic Course Manuals.

This document is intended for the use of **BHTI Sales Personnel** and for **prospective customers** as an aid in defining the features and benefits of the Bell Model 206B3 .

This document contains **proprietary material** of **BHTI**. Disclosure, reproduction, or use of any material in this document by persons **other than BHTI employees, and BHTI Independent Representatives [International Dealers]** is forbidden without written permission from **BHTI**.

The **PHOTOGRAPHS** and **DRAWINGS** used in this book are for **illustration** only, and may differ from the actual aircraft, as the **BHTI** continuing product improvement process causes some components, specifications, and procedures to be changed or replaced.

For the **MOST CURRENT** Model 206B3 tabular data, standard equipment list, optional equipment kits, and performance and fuel flow charts refer to the Bell 206B3 Technical Information Booklet. For performance and operational limitations for **actual mission planing** reference must **ALWAYS** be made to the FAA Approved Rotorcraft Flight Manual.



Two plates are installed in cabin for leveling, one in the ceiling and one in the floor. A plumb bob suspended from the upper plate will point to a special mark on the lower plate when the helicopter is level.

Structural provisions to support the optional cargo hook are included in the standard fuselage.

DYNAMIC COMPONENTS

THE ENGINE AND DRIVE TRAIN includes the transmission, the tail rotor drive shaft and the tail rotor gearbox.



Rear Tie-Down

02423

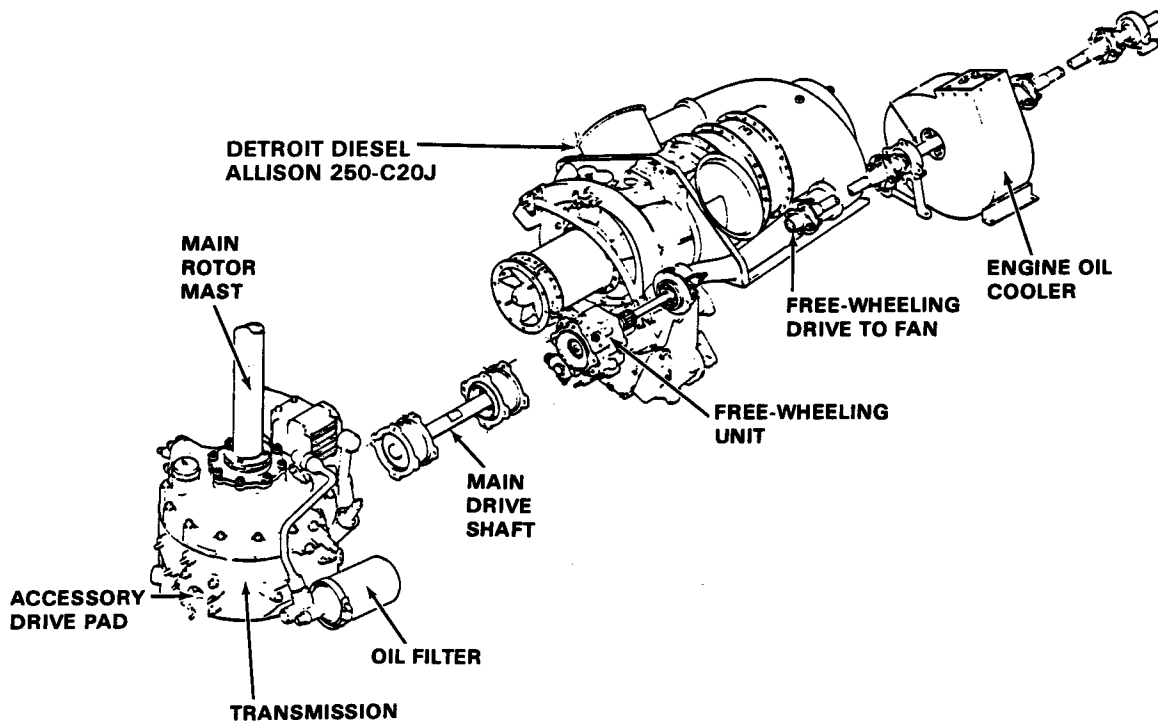



AN ALLISON MODEL 250-C20J GAS TURBINE ENGINE

drives the JetRanger III. Optimized for performance under hot day, high altitude conditions, the C20J packs a lot of power into a 72 kilogram, (158 pound) package. The Allison rating is 313 kW (420 SHP)

drive train and the exhaust system.

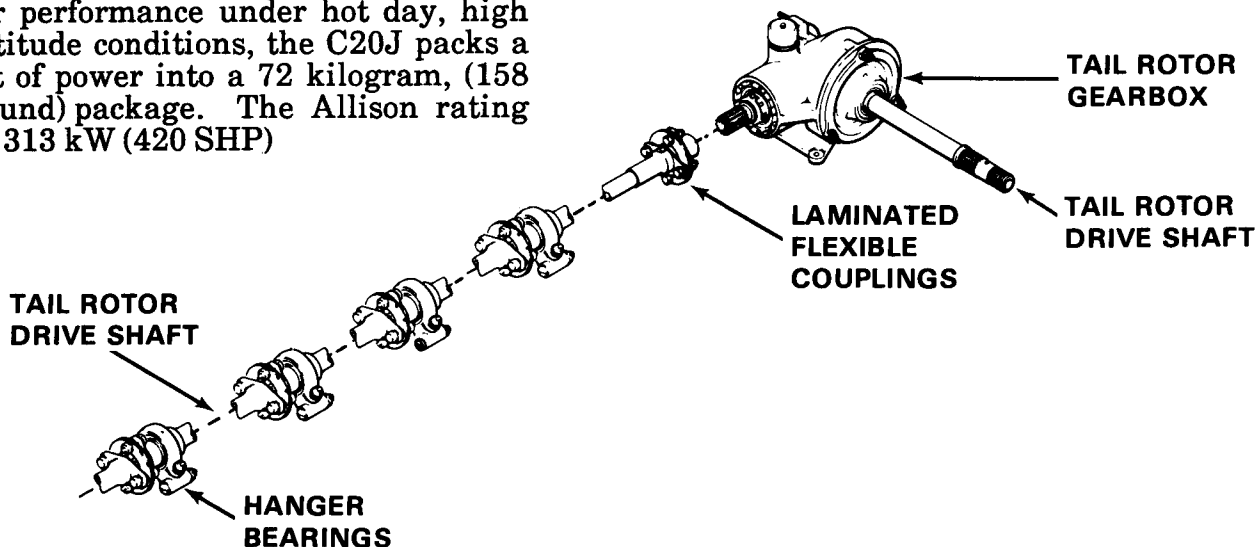

The Engine and Drive Train

but the engine is flat rated to the transmission limit of 236 kW (317 SHP), allowing the needed margin of safety in extreme operational environments.

The engine consists of multistage axial-centrifugal-flow compressor, a single combustion chamber, a two-stage gas producer turbine, and a two-stage power turbine which supplies the output power of the engine.

The 250-C20J engine is manufactured by Detroit Diesel Allison, a division of General Motors Corporation. It is installed on the roof of the intermediate section of the fuselage. This places the engine in the best position in relation to the passenger compartment and it also simplifies the

The engine is supported by three bi-pod struts. It is attached to the two forward struts with "Accousti Mounts" which isolate the engine noise from the airframe. All three struts have "clam shell" dampers which further reduce the noise transmitted through the struts.

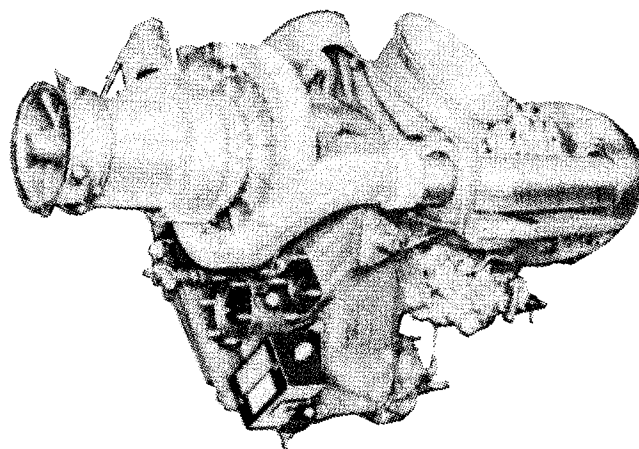



THIS IS AN UNCONTROLLED DOCUMENT. THE DATA IS PRESENTED FOR GENERAL INFORMATION ONLY. SOME INFORMATION HAS BEEN SUPERCEDED SINCE ORIGINAL PUBLICATION. PLEASE REFER TO THE CURRENT PRODUCT SPECIFICATION BOOKLET FOR UP-TO-DATE STANDARD EQUIPMENT LIST & KIT WEIGHTS, PERFORMANCE, AND DIRECT OPERATING COST.

BELL 206B JETRANGER III

The engine is coupled to the transmission through the free-wheeling unit and the main drive shaft.

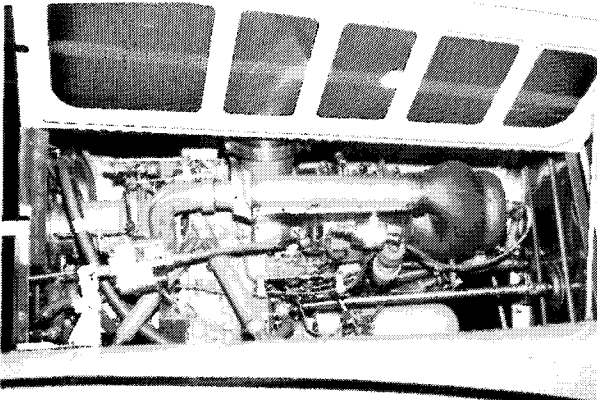

Left Side

310747

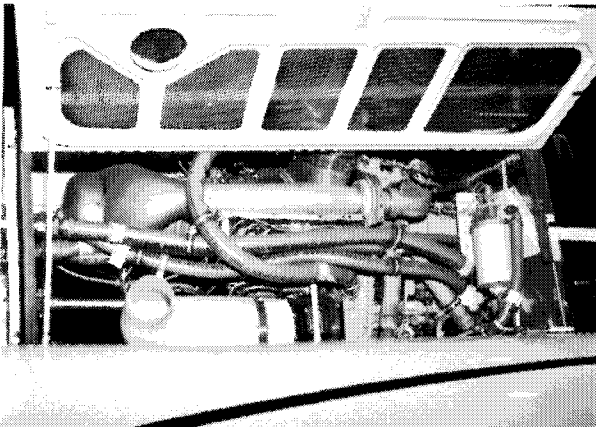

Right Side

310748

The sprag type free-wheeling unit is mounted on the engine gearbox. During autorotation, it provides a disconnect from the engine and allows autorotational forces of the main rotor to drive the transmission, tail rotor and all transmission accessories.

The engine is light in weight and minimum in size. It has maximum reliability, and is easy to maintain. In-the-field experience as well as thousands of hours of ground and flight testing have shown the C20J engine to be very adaptable to operating under severe and varying environmental conditions.

The "J" has only one difference from the earlier C20B model. The gear mesh from the power-take-off to the torque meter has been changed to raise the pitch of the gear noise from 5,000 to 6,000 hertz. Strange as it seems, this new frequency reduces cabin noise because the higher pitch

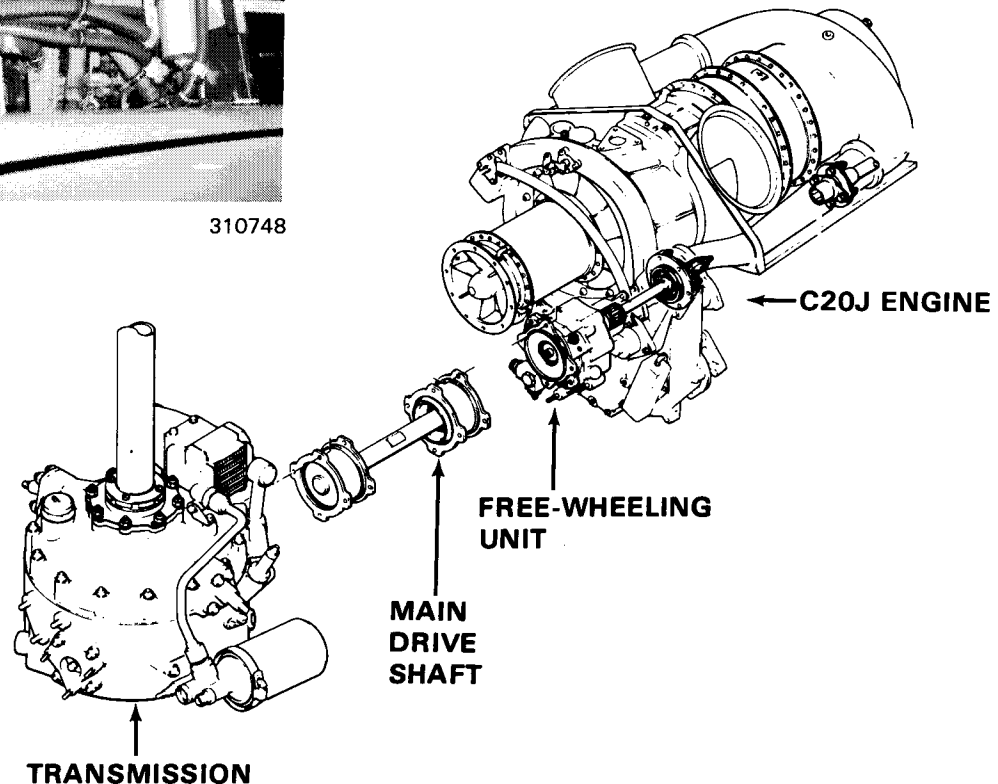

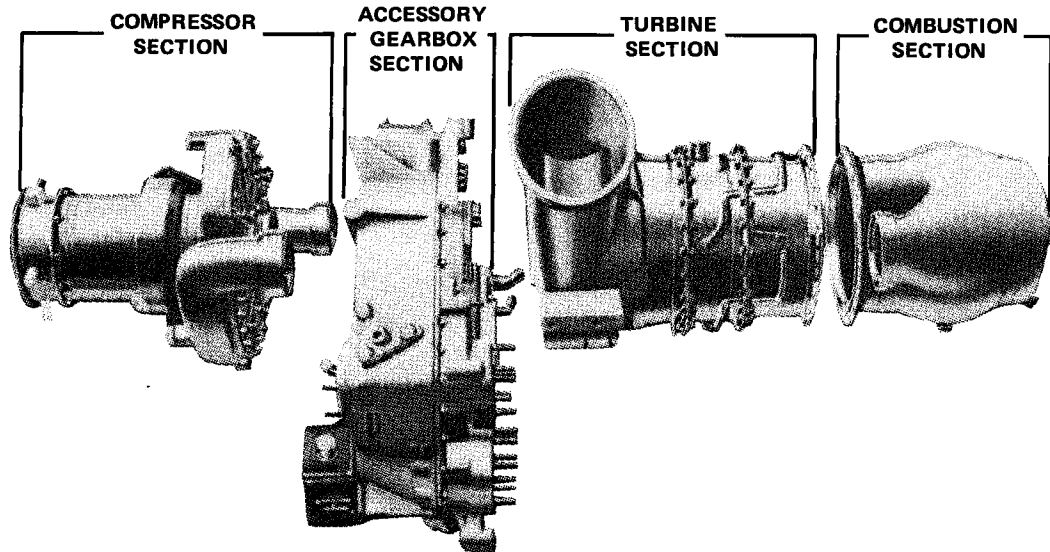

does not transmit as easily. The change is worthwhile because it reduces the high frequency noise in the cabin by about 20 decibels -- a significant improvement in the comfort level.

The high performance specifications for the 250-C20J look like this:

Weight	71.67 kg	(158 lb)
Power/Weight Ratio		2.66:1
Airflow	1.56 kg/sec	(3.45 lb/sec)
Pressure Ratio		7.2:1
Output shaft speed at 100%		6016 RPM
Fuels		JP-4, JP-5 ASTM D 1655
Oils		Type A, A1 or B MIL-L-7808 MIL-L-23699
Overall Dimensions	103.6 cm	(40.8 in) long
	48.3 cm	(19.0 in) wide
	58.9 cm	(23.2 in) high

It features modular design for easy access to the engine components. One component can be replaced quickly without disturbing the others. The modular design offers substantial direct operating cost advantages. Maintenance or overhaul of a single module can be accomplished independently of the remainder of the engine. A compressor, for instance, may be removed from the engine for repair or incorporation of the latest technical improvements while the engine remains in service using a replacement compressor.

All engine adjustments and almost all maintenance can be easily performed from ground level.

The hinged doors running the length of the engine, one on each side, may be opened individually or the whole engine cowling can be removed.

250-C20J Performance (Sea level static)

	Power		Fuel	
	(min.)		Consumption (max)	
	kW	(SHP)	kg/kW/h	(lb/shp-h)
Takeoff (5 min.)	313	(420)	0.395	(0.650)
Max Continuous	276	(370)	0.395	(0.650)
Cruise A (90%)	248	(333)	0.405	(0.665)
Cruise B (75%)	207	(278)	0.431	(0.709)

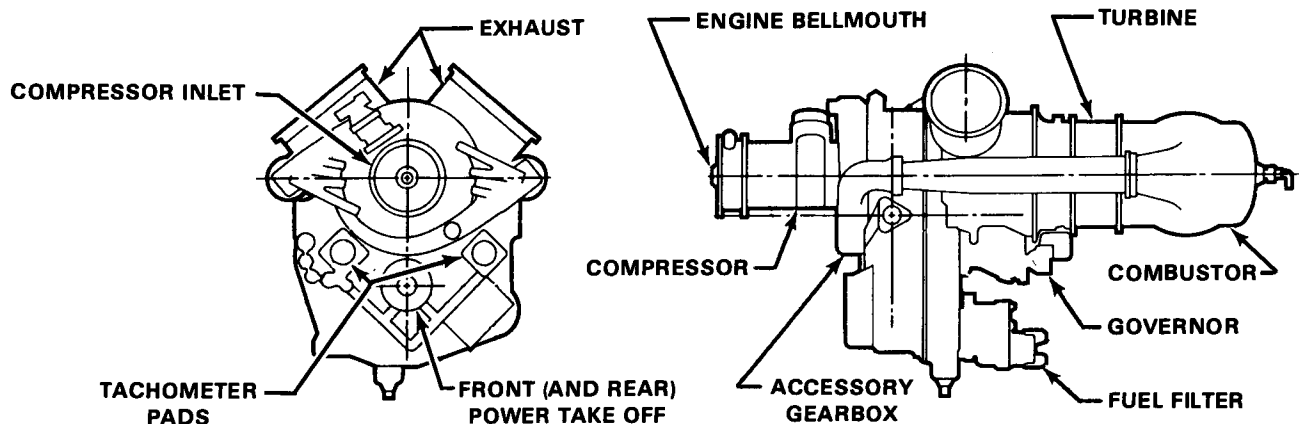

Air is supplied to the engine through airscoops on either side of the transmission. A protective induction screen is mounted in front of the engine bellmouth.

The power turbine and gas producer tachometer generators are mounted on the front of the engine on the left and right sides, respectively. The starter/generator is located on the right side. A turbine outlet temperature harness relays temperature measurements to an indicator on the instrument panel. An ENG OUT warning light on the caution panel illuminates when the gas producer tachometer rpm falls below a preset level.

The anti-icing system directs hot compressor discharge air over the compressor inlet guide vanes and front bearing support hub. The system is controlled by a switch on the radio pedestal.

The compressor wash system directs a spray of water toward the center of the engine bellmouth. The spray fitting is mounted on the inlet screen and the tubing is routed to the left side of the helicopter for easy access to an outside source of water.

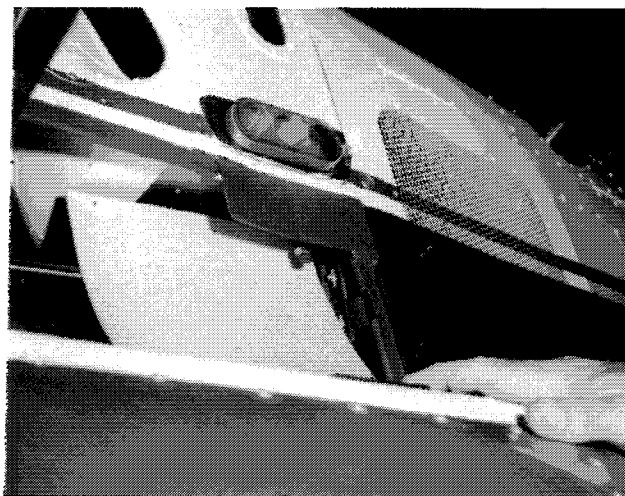

Compressor Wash Inlet

008976



An hour meter, mounted in the battery compartment operates in conjunction with the engine rpm sensor. It gives an accumulative total of the engine running time. A specially keyed reset switch for the TOT Overtemp Warning Light is located next to the hour meter.

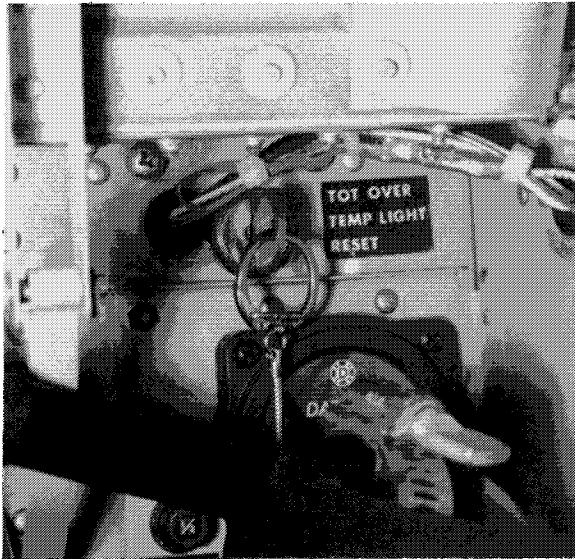

Hour Meter & TOT Light Reset

A start counter, mounted on the engine, records the total starts, counting one each time the ignition system is energized.

The basic principle of a gas turbine is quite simple -- continuous combustion that produces a steady flow of efficient power.

- air enters the compressor (1) and is compressed to over seven times normal atmospheric pressure

- twin air transfer tubes (2) direct this compressed air into the combustion chamber (3)

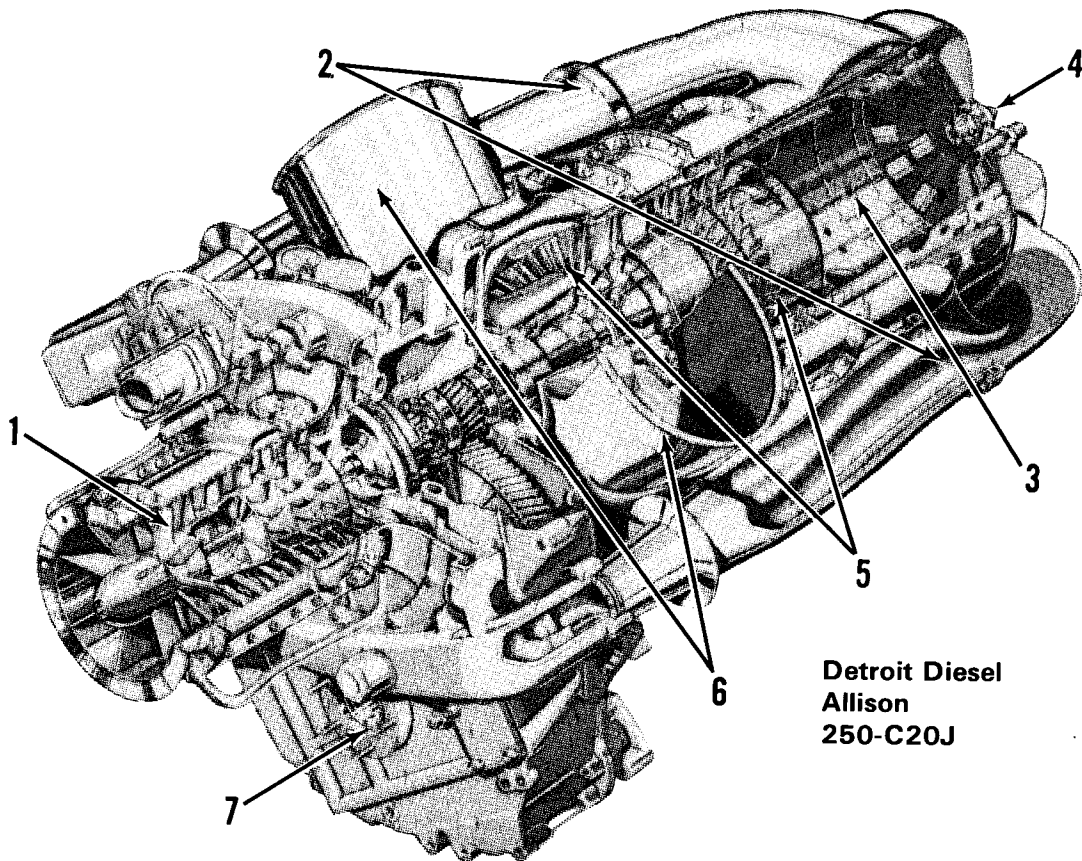

**Detroit Diesel
Allison
250-C20J**



- fuel is injected and the mixture is ignited. A spark igniter (4) and a fuel nozzle are mounted in the aft end of the outer combustion case
- hot gases flow forward and expand through four turbine stages
- the first two turbine stages provide power to drive the compressor

- the two-stage free power turbine converts most of the remaining energy to useful power at the output shaft through reduction gears
- the exhaust gases exit (6)
- the power output shaft (7) at 6016 rpm (after entering the accessories gearcase at 33290 rpm) is available at either front or rear output pads.

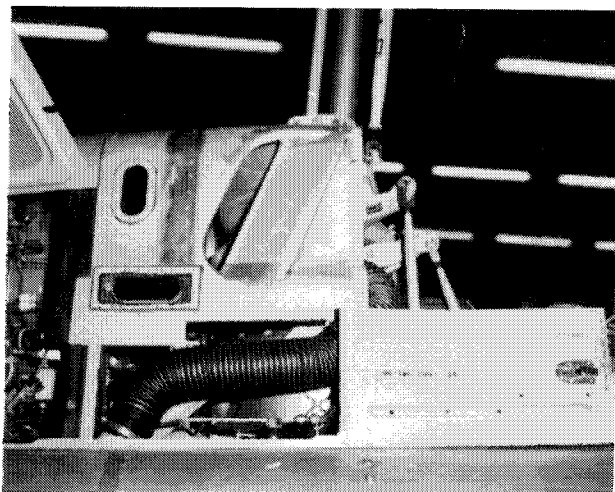
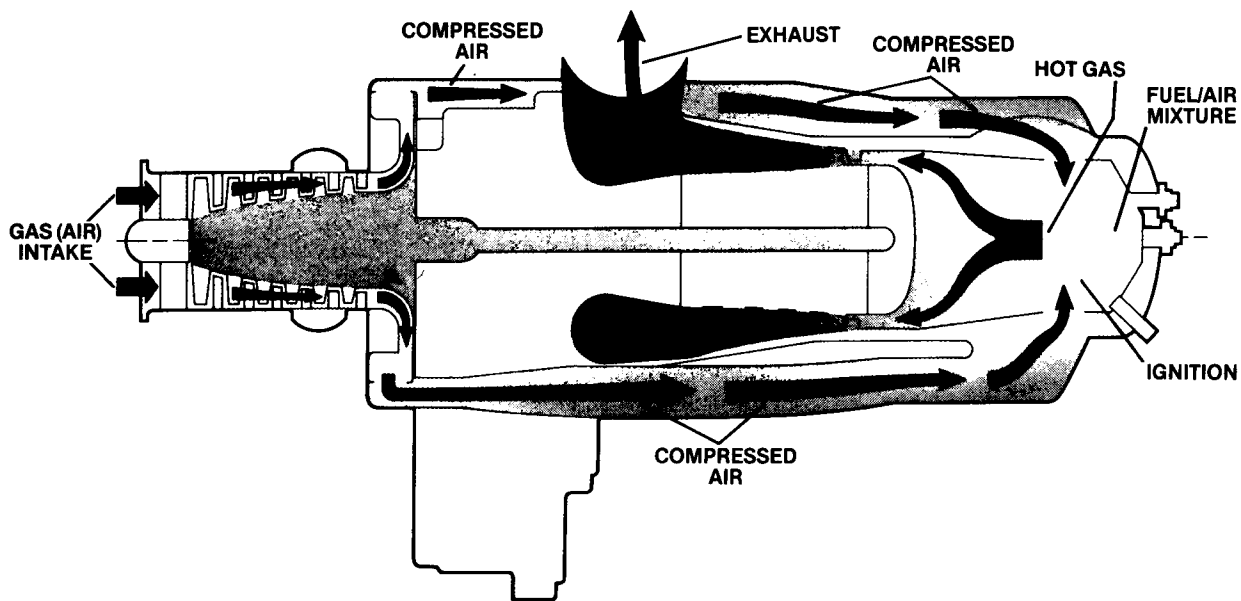

Left Side

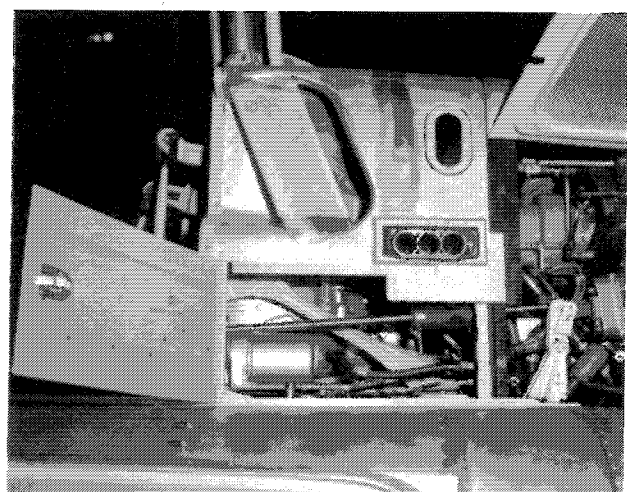

Right Side

02279



ALLISON 250-C20R4 PRODUCTION OPTION

In 1990, Bell Helicopter Textron began to offer the Allison 250-C20R4 engine as a standard production option in the Model 206B-III. Installation in the JetRanger III is through a Supplemental Type Certificate which was granted jointly to Allison and Soloy Conversions, Ltd.

With its additional power capability -- 335KW(450SHP) take-off rating and 283KW(380SHP) continuous rating -- the C20R4 provides a further safety margin wherein the JetRanger III may operate without concern for engine power limitations.

Significant changes have also been made to enhance the reliability of the C20R when compared to the C20J. (Initial TBO's and retirement hours remain the same as the C20J.)

Some of the key features of the C20R are shown below.

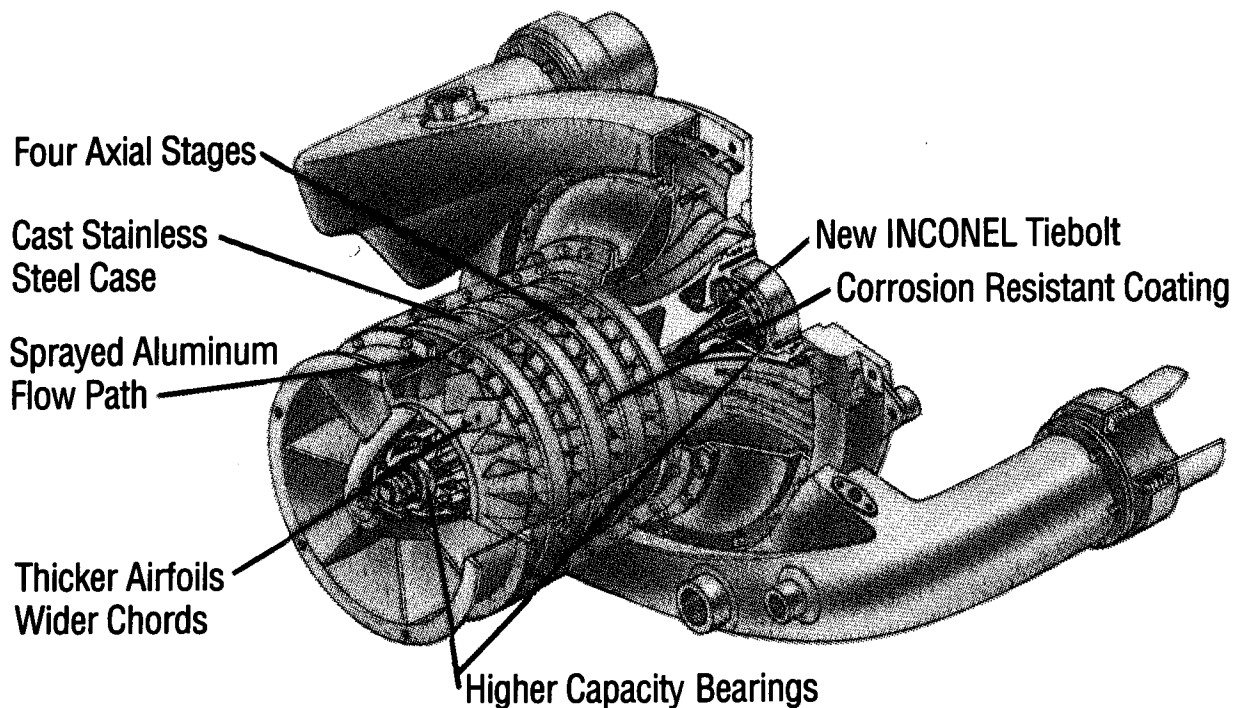

An advanced design compressor is included. The compressor has four axial stages, and one centrifugal stage. It is designed to provide greater airflow and pressure ratio, increase efficiency, add reliability and lengthen component life.



THIS IS AN UNCONTROLLED DOCUMENT. THE DATA IS PRESENTED FOR GENERAL INFORMATION ONLY. SOME INFORMATION HAS BEEN SUPERCEDED SINCE ORIGINAL PUBLICATION. PLEASE REFER TO THE CURRENT PRODUCT SPECIFICATION BOOKLET FOR UP-TO-DATE STANDARD EQUIPMENT LIST & KIT WEIGHTS, PERFORMANCE, AND DIRECT OPERATING COST.

BELL 206B JETRANGER III

The gearbox has been modified only slightly, primarily to add life to the bearings. Oil distribution to the #2 bearing has been modified, squeeze film damping is provided and the material in the power takeoff and torque meter bearings has been improved. In addition, power takeoff and torque meter gears incorporate the 6000 Hz mesh frequency to reduce cabin noise.

Provide #2 Bearing
Squeeze Film Damping
Improved Material -
Torquemeter Front Bearing
Improved Material -
PTO Rear Bearing

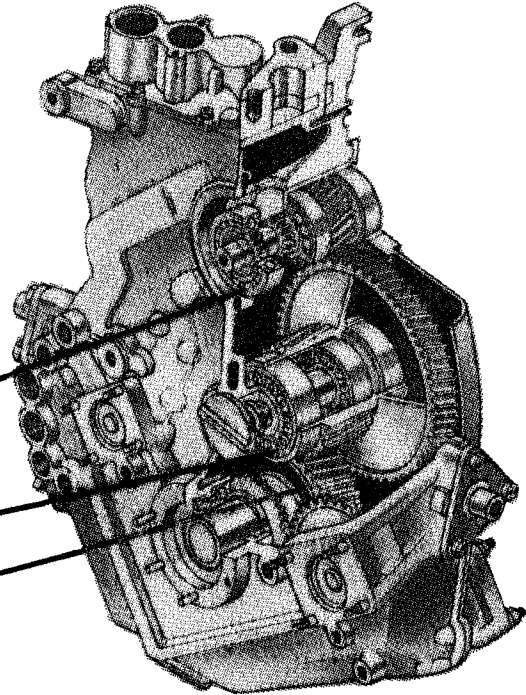

The power turbine remains essentially the same except for the addition of an energy absorbing ring over the first stage wheel to provide airframe protection in the event of a wheel failure.

Modified Flow Area -
1st, 3rd & 4th Stage Nozzles
Floating Diaphragm -
1st & 4th Stage Nozzles

Energy Absorbing Ring

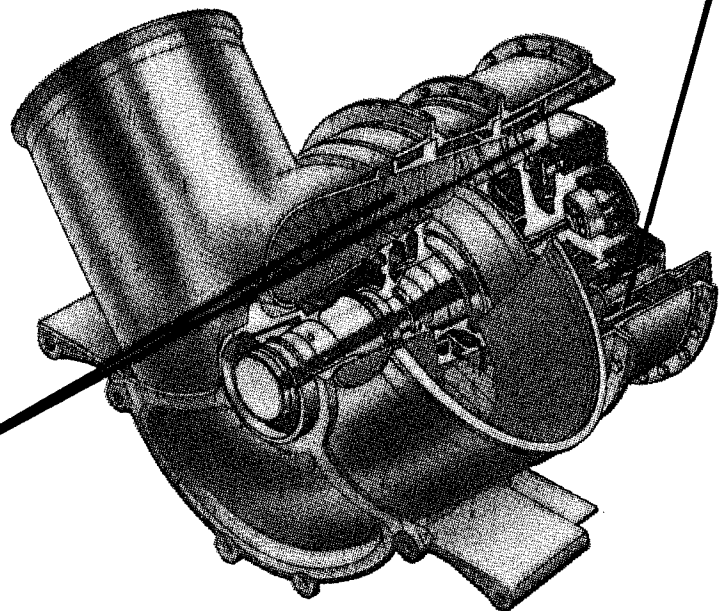



THIS IS AN UNCONTROLLED DOCUMENT. THE DATA IS PRESENTED FOR GENERAL INFORMATION ONLY. SOME INFORMATION HAS BEEN SUPERCEDED SINCE ORIGINAL PUBLICATION. PLEASE REFER TO THE CURRENT PRODUCT SPECIFICATION BOOKLET FOR UP-TO-DATE STANDARD EQUIPMENT LIST & KIT WEIGHTS, PERFORMANCE, AND DIRECT OPERATING COST.

BELL 206B JETRANGER III

The combustor has been improved. The outer case and the air discharge tubes have increased in thickness. The tubes also incorporate a new expansion bellows and a bolt-on front flange to maintain an air tight seal.

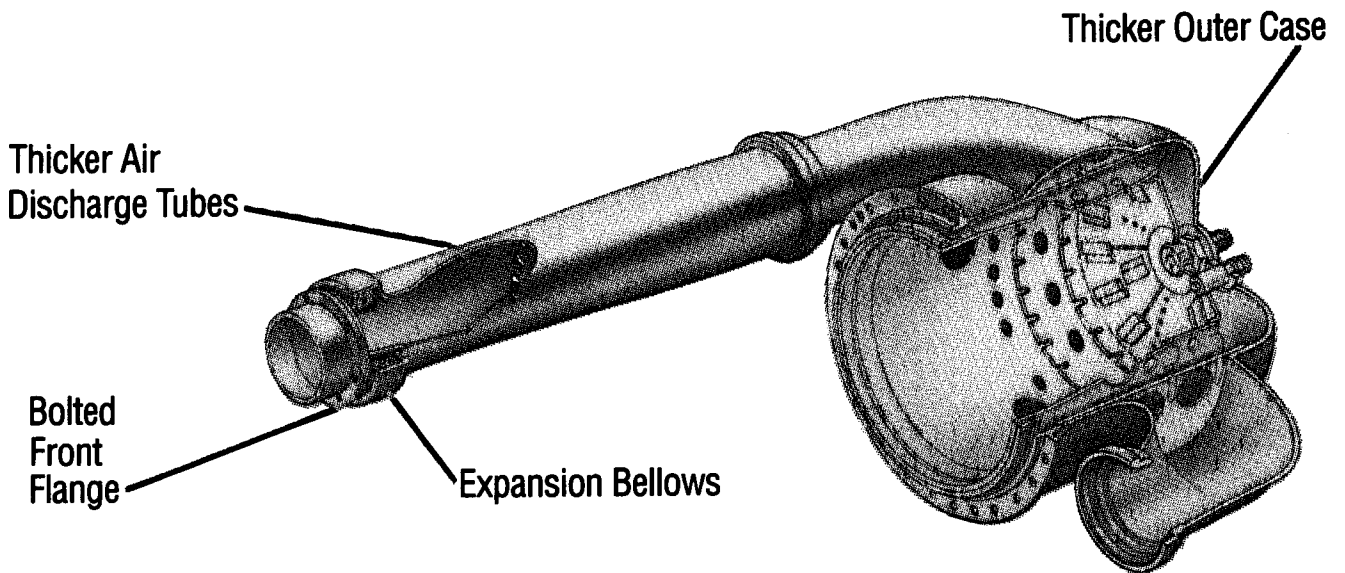

Thermodynamically, the engine will develop considerably more horsepower; however, in the JetRanger, this increased power performance is available only if off the XMSN torque limit. Generally speaking, this will be in an OGE hover above 10,000 feet altitude on a standard day and above 6000 feet on an ISA + 20°C day.

IGE, the performance will be improved at altitudes above 12,800 feet on a standard day or above 10,200 feet on an ISA + 20° C day. Following is a chart showing the performance gains.



THIS IS AN UNCONTROLLED DOCUMENT. THE DATA IS PRESENTED FOR GENERAL INFORMATION ONLY. SOME INFORMATION HAS BEEN SUPERCEDED SINCE ORIGINAL PUBLICATION. PLEASE REFER TO THE CURRENT PRODUCT SPECIFICATION BOOKLET FOR UP-TO-DATE STANDARD EQUIPMENT LIST & KIT WEIGHTS, PERFORMANCE, AND DIRECT OPERATING COST.

**BELL 206B
JETRANGER III**

**HOVER PERFORMANCE COMPARISON
JETRANGER III WITH C20B/J, C20R ENGINES
DATA FROM FAA-APPROVED FLIGHT MANUALS
BASIC INLET**

(ALTITUDE IN FEET)

GROSS WEIGHT, LBS		2600	3000	3200
IGE-Standard Day	C20B/J	16,000 (1)	14,800	12,800
	C20R	16,000 (1)	16,000 (1)	13,500 (2)
IGE-ISA + 20° C	C20B/J	13,800 (1)	12,200	10,200
	C20R	13,800 (1)	13,800 (1)	11,200 (2)
OGE-Standard Day	C20B/J	16,000 (1)	10,600	8800 (3)*
	C20R	16,000 (1)	12,000	6400 (4)
OGE-ISA + 20° C	C20B/J	12,000	7600	4000 (4)
	C20R	13,800 (1)	9700	4000 (4)

Anti-Ice on (only required if OAT is below 40° F [4° C] and visible moisture).

Subtract lbs from hover gross weight	}	C20B/J	220	IGE,	295	OGE
		C20R	230	IGE,	240	OGE

With Particle Separator Installed

C20B/J Hover Ceiling decreases 400 feet to 1000 feet when on engine limits
C20R Hover Ceiling decreases 500 feet to 900 feet when on engine limits

- Notes: (1) *Flight Manual* data limited to 16,000 ft density altitude for all gross weights.
(2) *Flight Manual* data limits of 13,500 ft density altitude for gross weights above 3000 lbs.
(3) Without accounting for torque limit. *With torque limit - 6400 lbs.
(4) Torque limited.

Included in the C20R production option are all the necessary modifications to the JetRanger III's airframe, electrical system and instrumentation. They are a heavy duty battery (17 ampere hour), increased capacity wiring from the battery to the starter/generator and a different TOT gage.

Production availability of the C20R equipped JetRanger III requires a greater lead time than the standard C20J JetRanger III. Customers considering this alternate configuration are encouraged to contact their Bell Helicopter Textron Marketing Representative to discuss mission requirements/suitability of the C20R and to discuss availability.



THE ENGINE OIL SYSTEM

is a circulating dry sump type with an external reservoir and oil cooler. Pressure and scavenge pumps are mounted within the engine and are driven by the accessory gearbox. All engine oil system lines and connections are internal with the exception of the pressure and scavenge lines to the front and rear bearings.

A blower driven by the tail rotor drive shaft provides cooling air to the oil cooler. An oil temperature bulb installed in the supply tank is connected to an indicator on the instrument panel. A chip detector illuminates a light on the caution panel when metal particles are detected in the system.

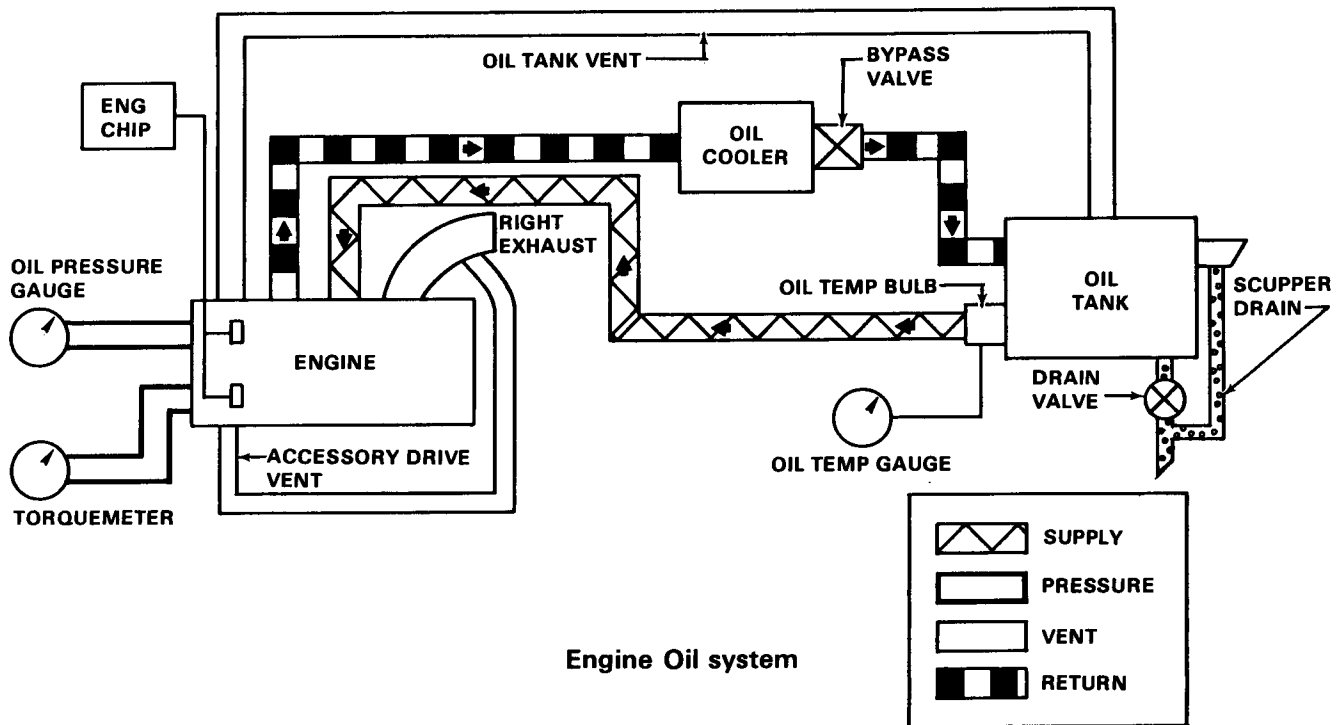

Right Side

02279



THE *JETRANGER* FUEL SYSTEM consists of:

- A single, bladder-type, fuel cell located in the aft passenger seat bench with a fuel capacity of 344 liters (91 US gallons). The cell has been reinforced to withstand the "50-foot drop test".
- An engine-driven fuel pump and a fuel filter both mounted on the engine.
- Two electric submerged boost pumps in the fuel cell, connected in parallel to the engine fuel supply line. The pumps can be removed for repair or replacement from the bottom of the fuselage.
- A fuel pump caution light to inform the pilot if either of the boost pumps malfunctions.
- Two fuel-level transmitters connected to one indicator on the instrument panel.
- An airframe-mounted fuel filter with a replaceable element and a switch to activate the airframe fuel filter bypass caution light.

- A single filler cap located on the right side of the helicopter just aft of the passenger door. A grounding plug is located nearby.

- An electric, fuel-ump drain valve operated by a push-button just below the filler cap.

- A fuel shut-off valve electrically operated by a switch on the instrument panel.

- A transducer to activate the fuel pressure gauge.

FUEL CONTROL PANEL



Fuel Controls

23724

FILLER CAP

GROUNDING JACK

PUSH BUTTON
DRAIN SWITCH

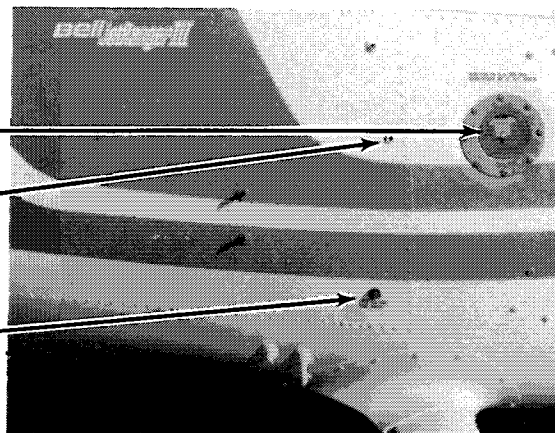

Fuel Filler Cap

02279

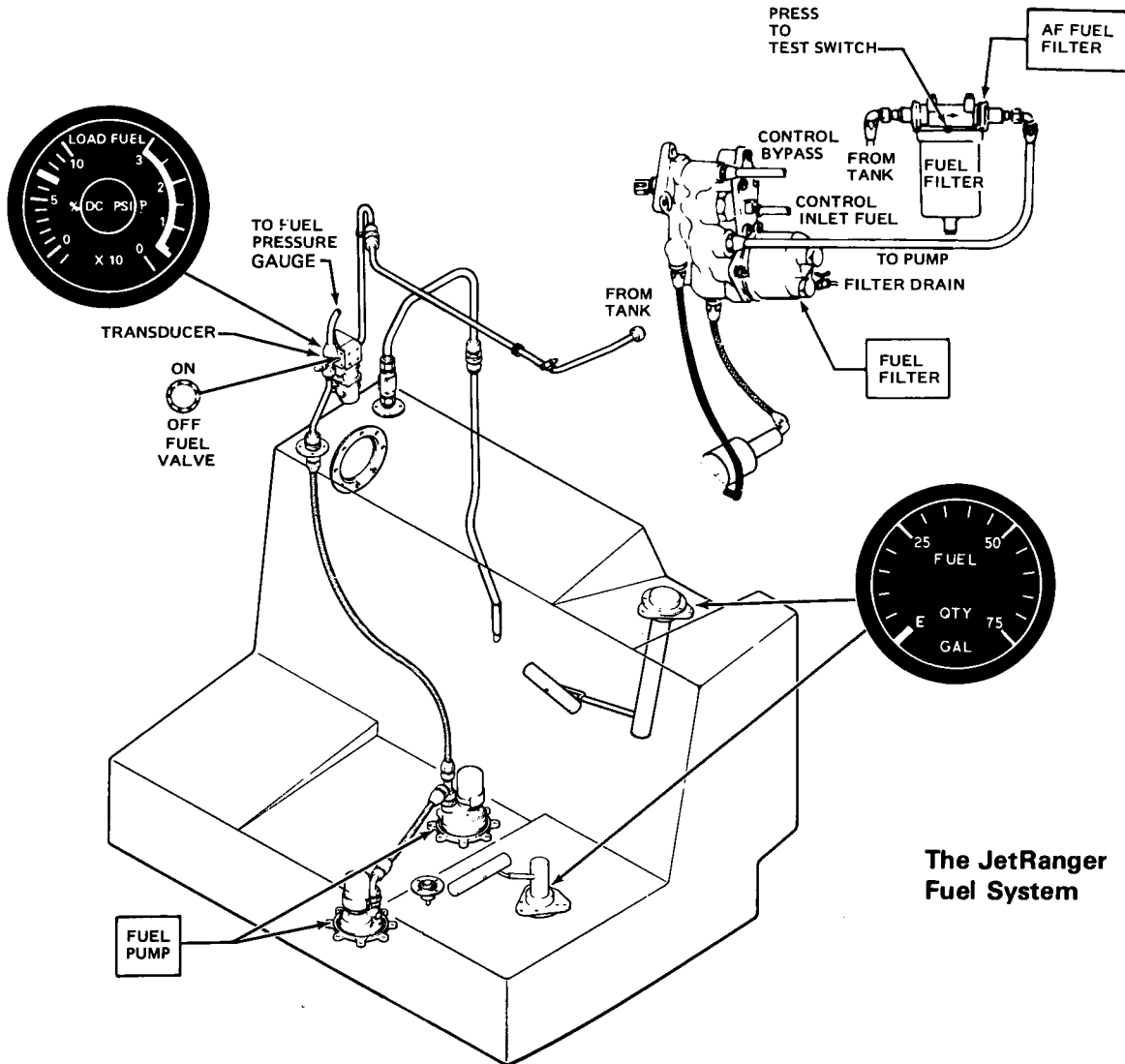

**The JetRanger
Fuel System**

The honeycomb box structure which forms the passenger seat bench provides the fuel cell with a rugged, damage resistant cavity. The smooth fiberglass inner surface further reduces risk of cell rupture, thus sharply reducing the fire hazard.



JetRanger III

011660



THIS IS AN UNCONTROLLED DOCUMENT. THE DATA IS PRESENTED FOR GENERAL INFORMATION ONLY. SOME INFORMATION HAS BEEN SUPERCEDED SINCE ORIGINAL PUBLICATION. PLEASE REFER TO THE CURRENT PRODUCT SPECIFICATION BOOKLET FOR UP-TO-DATE STANDARD EQUIPMENT LIST & KIT WEIGHTS, PERFORMANCE, AND DIRECT OPERATING COST.

BELL 206B JETRANGER III

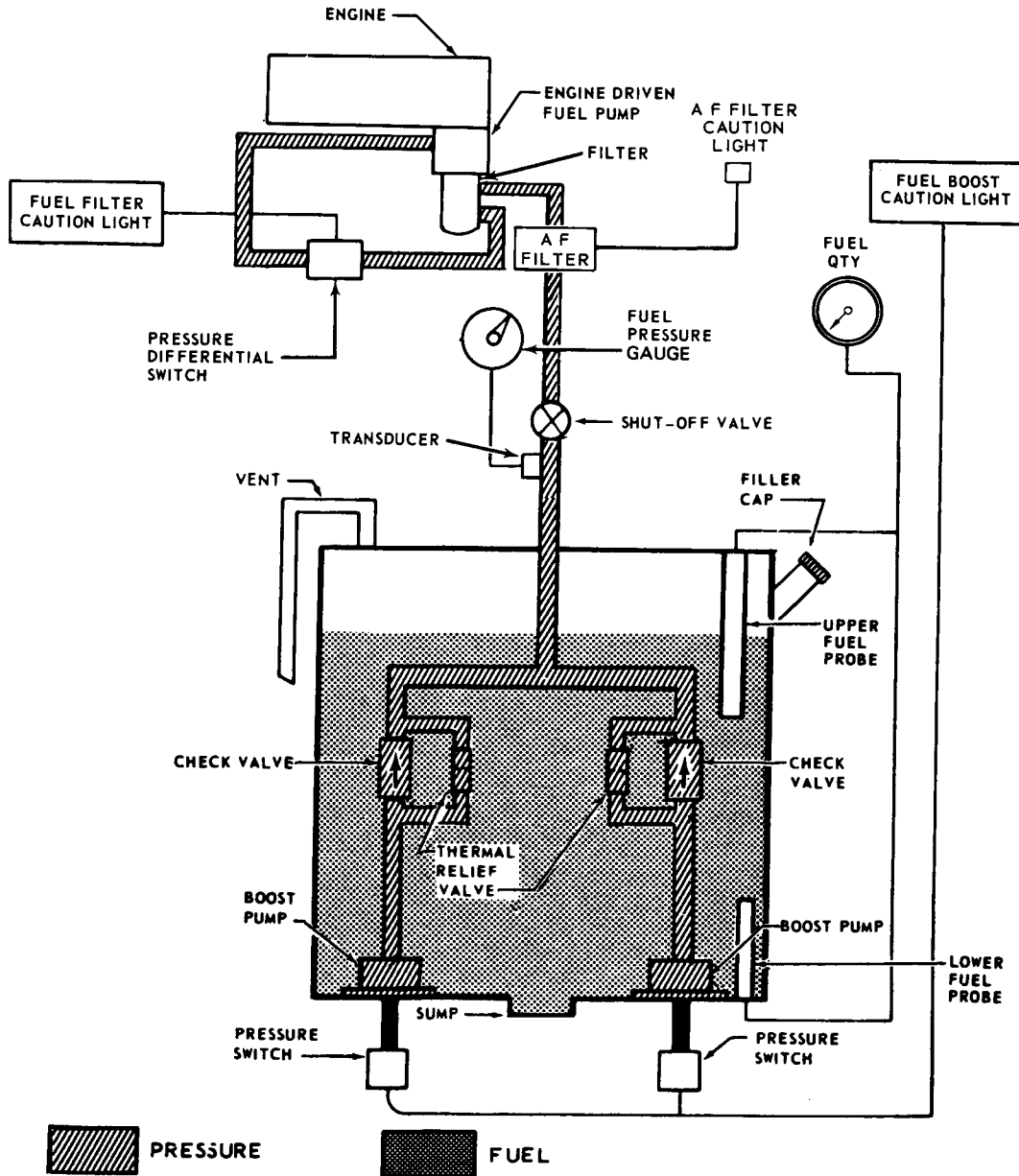

Fuel System Schematic



THE TRANSMISSION

is mounted on the cabin roof forward of the engine by a pair of pylon support links or "A frames". It is a unique isolation mount which reduces airframe vibration and permits higher flight speeds without compromising pilot comfort or the fatigue life of the airframe and dynamic parts.

The transmission is coupled to the engine by means of a short drive shaft. Basically, the transmission is a reduction gearbox which transmits engine power to the main rotor at reduced rpm by means of a spiral bevel gear and a planetary gear. The transmission, with its total of eight precision gears, reduces engine output rpm to the rotor from 6016 to 394.

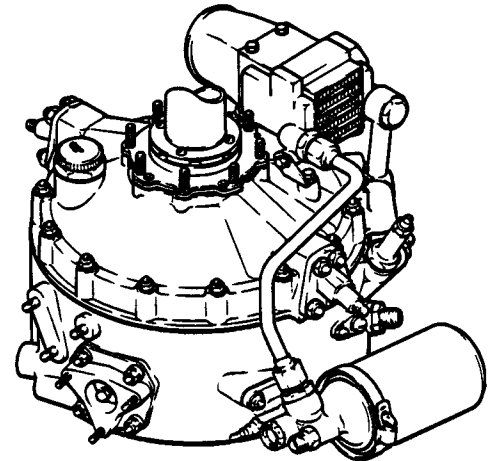
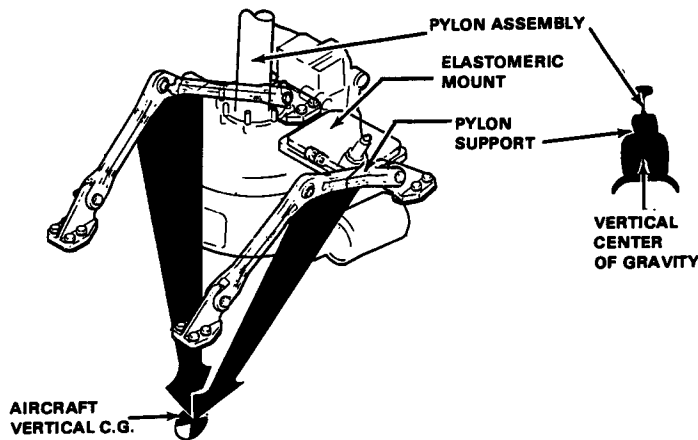

This support system differs from the conventional four or five point spring-mounted arrangement in that the bi-pod supports aim or focus the pylon input loads at the fuselage vertical center of gravity.

The use of elastomerics provides pylon static centering.

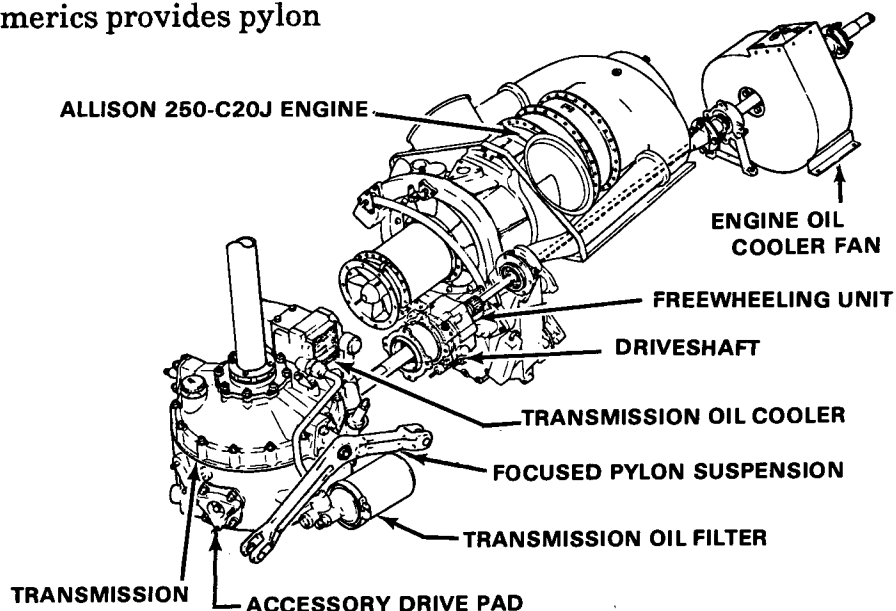



THIS IS AN UNCONTROLLED DOCUMENT. THE DATA IS PRESENTED FOR GENERAL INFORMATION ONLY. SOME INFORMATION HAS BEEN SUPERCEDED SINCE ORIGINAL PUBLICATION. PLEASE REFER TO THE CURRENT PRODUCT SPECIFICATION BOOKLET FOR UP-TO-DATE STANDARD EQUIPMENT LIST & KIT WEIGHTS, PERFORMANCE, AND DIRECT OPERATING COST.

**BELL 206B
JETRANGER III**

**TWO STAGE REDUCTION
15.23 TO 1.0**

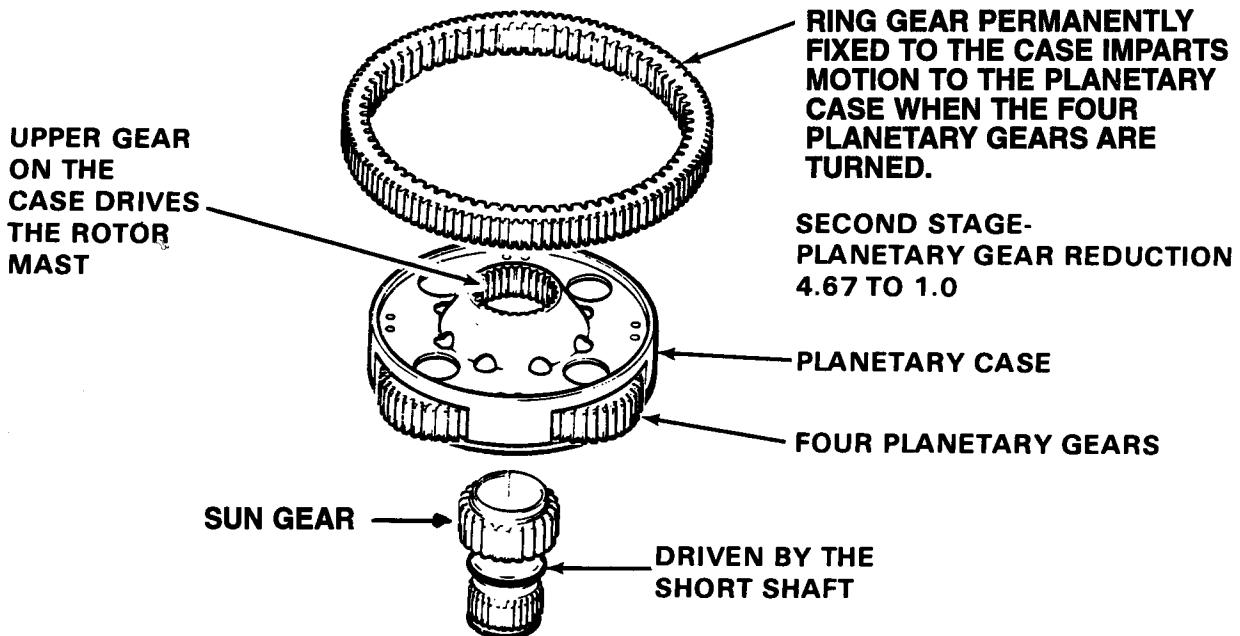
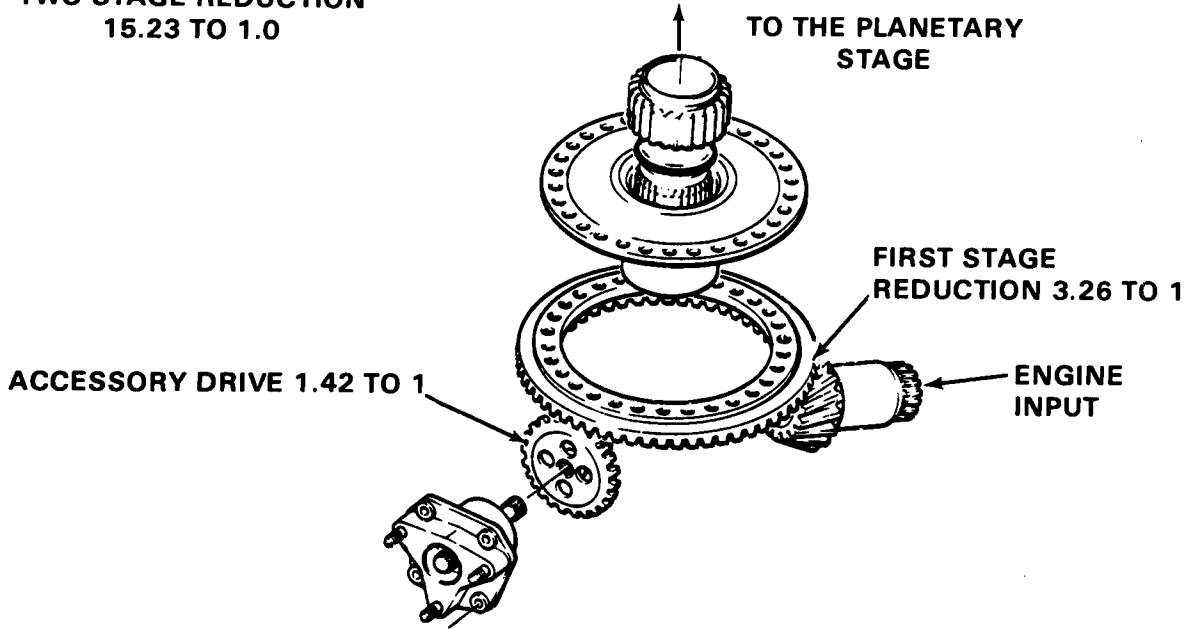



THE FIRST STAGE IS AT THE BOTTOM OF THE TRANSMISSION CASE.

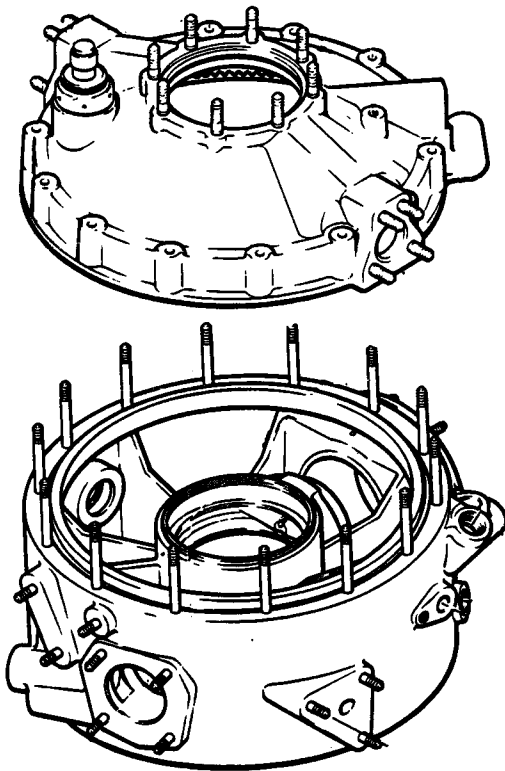

ROTOR MAST TURNS WITH THE PLANETARY CASE.

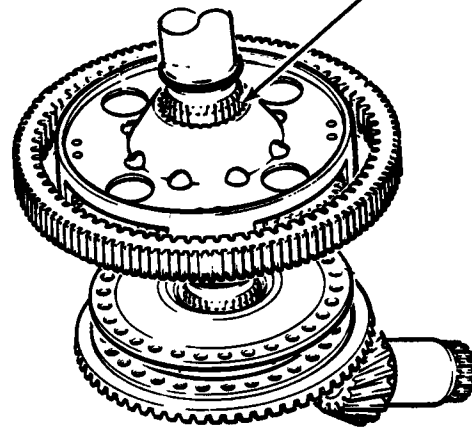

A self-contained lubrication system for the transmission and the free-wheeling unit is incorporated.

An accessory-drive bevel gear on the forward left side drives the transmission oil pump. It, in turn, is equipped with a pad on which the hydraulic pump is installed, and the hydraulic pump is equipped with one on which the tachometer generator is installed.

The transmission oil pump is a constant-volume submersed type that forces oil out of the sump to a filter on the left side and on to an oil cooler on the aft side. Both the filter and the cooler are mounted on the transmission.

From the cooler, the oil is circulated to the oil jets in the transmission and free-wheeling unit.

The oil filter assembly contains a bypass valve, a high-temperature warning switch, a thermobulb, a magnetic chip detector and a drain valve. It has a replaceable filter element.

The oil cooler contains a thermal valve that allows oil to bypass until it warms up.

The self-contained transmission lubrication system has a capacity of 4.1 liters (5 U.S. quarts).

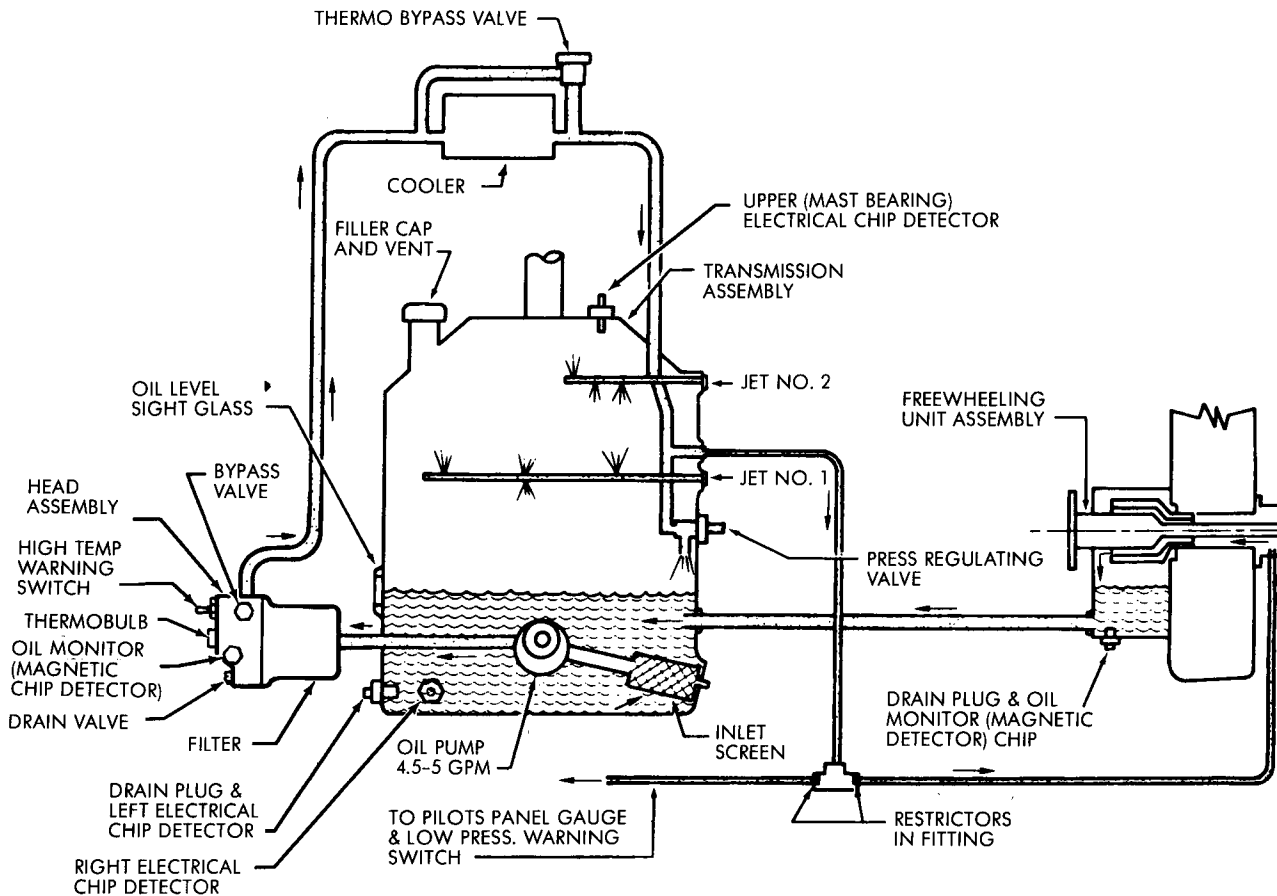

Lights on the caution panel warn the pilot of loss of oil pressure and/or excessive oil temperature.

Three electric chip detectors are located in the transmission; two near the oil sump, and one near the mast bearing. These detectors have a permanent nonconducting magnet surrounding an electric probe. When a sufficient number of metal particles accumulate to complete the circuit, the TRANS CHIP light on the caution panel illuminates.

Two magnetic chip detectors (visual inspection type) are also in the lubrication system to act as oil monitors, one in the freewheeling unit and another one is in the fitter housing on the inlet port.

A breather-type filler cap and an oil level sight gauge are located on the

transmission top case and the right side of the lower case, respectively.

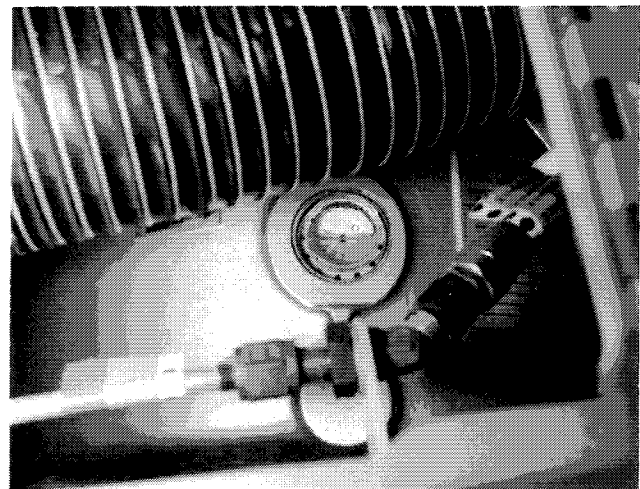

**Transmission Oil Level
Sight Gauge**

02247



THIS IS AN UNCONTROLLED DOCUMENT. THE DATA IS PRESENTED FOR GENERAL INFORMATION ONLY. SOME INFORMATION HAS BEEN SUPERCEDED SINCE ORIGINAL PUBLICATION. PLEASE REFER TO THE CURRENT PRODUCT SPECIFICATION BOOKLET FOR UP-TO-DATE STANDARD EQUIPMENT LIST & KIT WEIGHTS, PERFORMANCE, AND DIRECT OPERATING COST.

BELL 206B
JETRANGER III

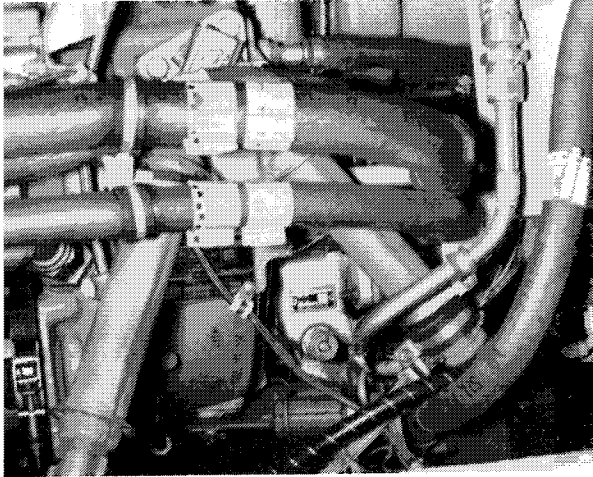

Freewheeling Unit Magnetic Plug

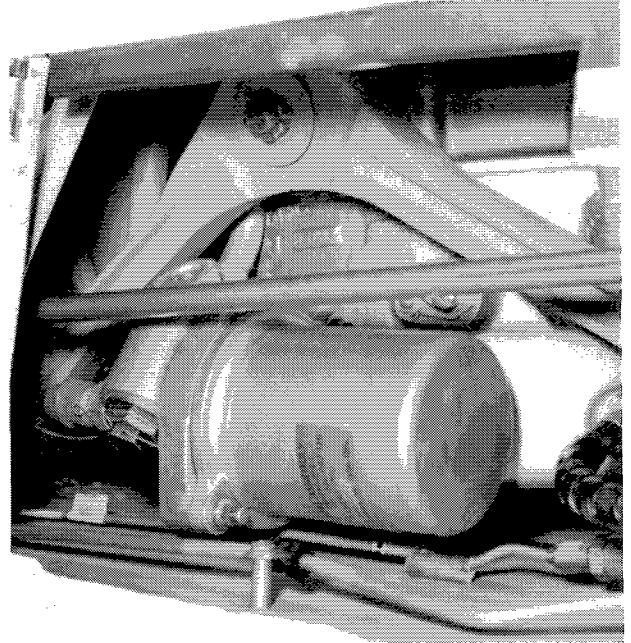

Oil Filter Magnetic Plug

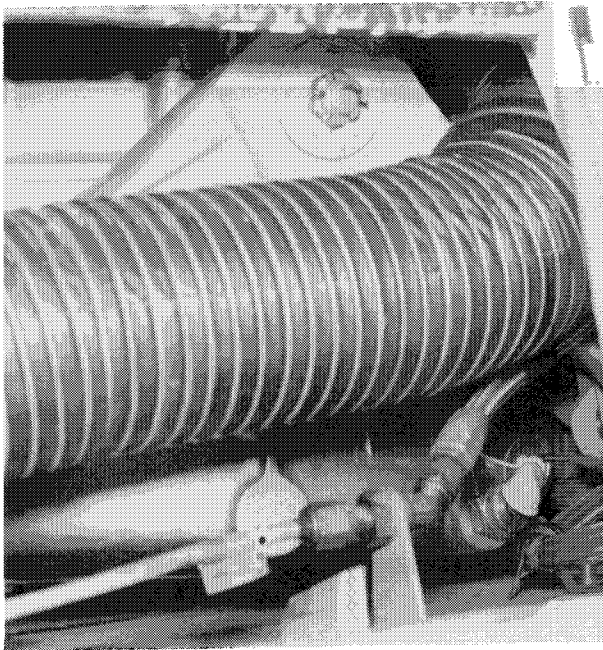

**Transmission (right)
Chip Detector**



THE MAIN ROTOR MAST is a tubular steel shaft that transmits rotational speed to the main rotor. Splines on the lower portion mate with those of the transmission planetary gear.

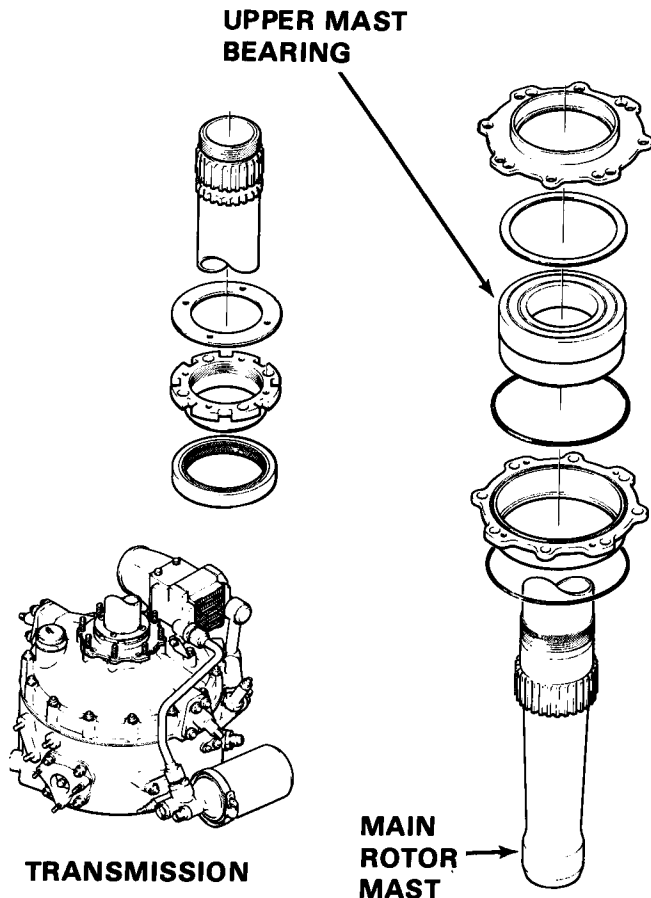

The JetRanger uses an underslung-feathering-axis (UFA) hub. The UFA hub, with only six bearings that require grease, is mechanically simple and provides good stability and quick control response.

The hub assembly consists primarily of a yoke fitted onto a splined trunnion and secured with pillow blocks; a pitch horn and grip assembly attached to each arm of the yoke with a tension torsion strap; and a blade-latch mechanism located between the upper and lower tangs of each grip assembly.

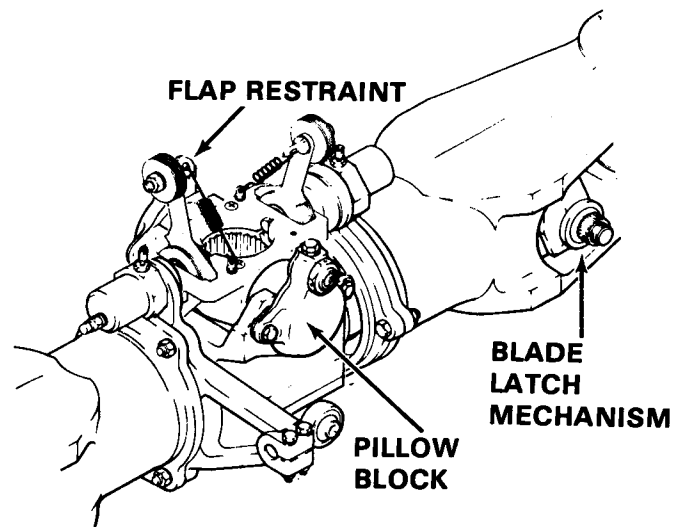

The main rotor is a semi-rigid, teetering type with two interchangeable blades.

High inertia means a forgiving rotor. Twenty-four pounds of weight in each blade increase stability and assure high blade energy for safe, easy autorotations. Safety and survivability are the pilot's inheritance in the JetRanger where high inertia permits zero speed touchdowns even at the maximum gross weight.

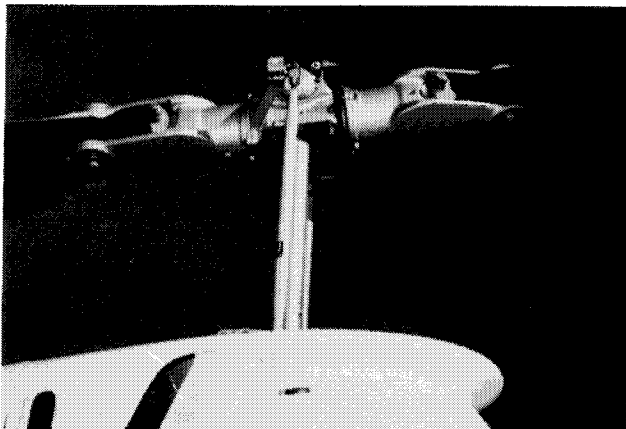

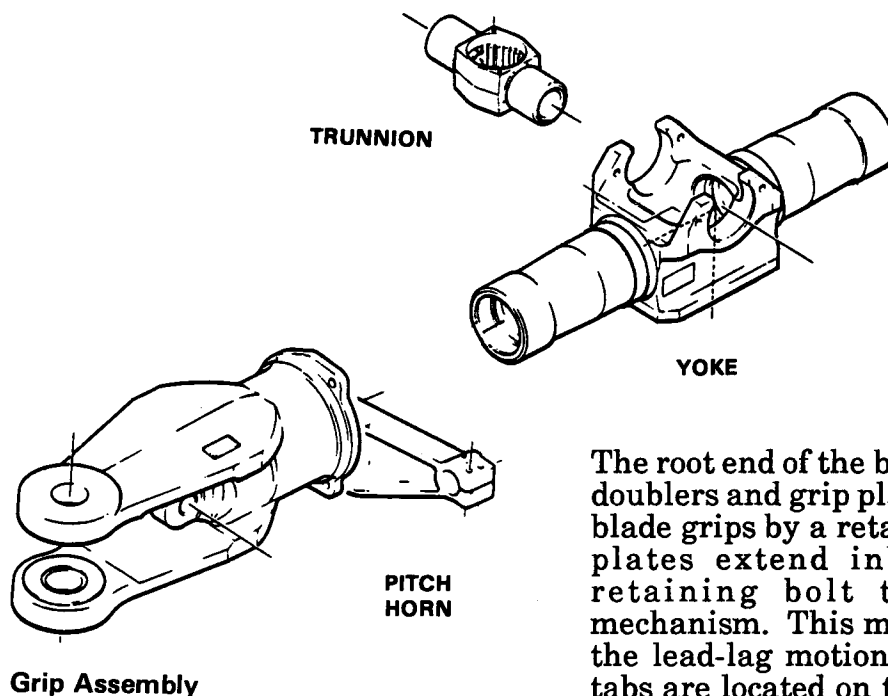

The root end of the blade, reinforced with doublers and grip plates, is secured to the blade grips by a retaining bolt. The grip plates extend inboard beyond the retaining bolt to a blade latch mechanism. This mechanism constrains the lead-lag motion of the blade. Trim tabs are located on the outboard trailing edge for tracking adjustment.

For the pilot, additional significant advantages of the JetRanger's two-bladed, semirigid rotor include:

-- No Control Loss With Stall:

The onset of retreating blade stall does not induce pitching moments as in articulated rotors.

-- Low Gust Sensitivity:

High kinetic energy reduces the effect of turbulence.

The flap restraint prevents excessive flapping that may occur during startup and shutdown under gusty wind conditions.

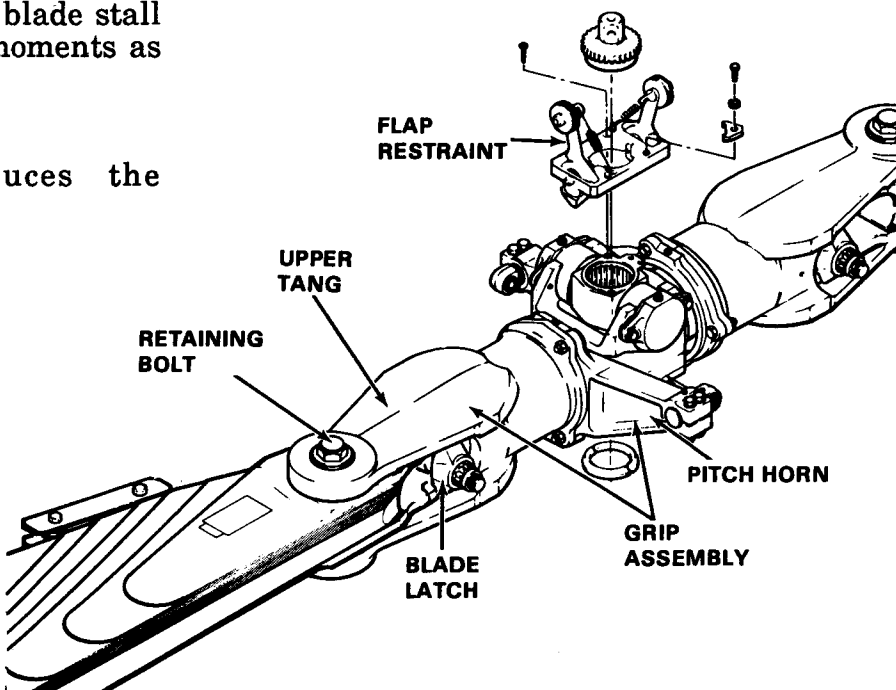



THIS IS AN UNCONTROLLED DOCUMENT. THE DATA IS PRESENTED FOR GENERAL INFORMATION ONLY. SOME INFORMATION HAS BEEN SUPERCEDED SINCE ORIGINAL PUBLICATION. PLEASE REFER TO THE CURRENT PRODUCT SPECIFICATION BOOKLET FOR UP-TO-DATE STANDARD EQUIPMENT LIST & KIT WEIGHTS, PERFORMANCE, AND DIRECT OPERATING COST.

BELL 206B JETRANGER III

The flap restraint mechanism is installed on top of the trunnion and engages between 100 and 125 rpm.

The design stresses safety and simplicity.

The main rotor blade has qualities of advanced aerodynamic efficiency, ruggedness, and simplicity blended in a design to satisfy the basic criteria and still leave a margin of safety for the pilot.

The JetRanger uses a **droop-snoot airfoil** section. Rotor blade efficiency is significantly improved compared to symmetrical blade shapes. A wide thrust margin for maneuverability and high efficiency in a hover, particularly under adverse conditions of gross weight, temperature and altitude, are, in part, the result of this airfoil design.

The blade is bonded, using six basic aluminum-alloy parts. A honeycomb core provides a rugged, light structure and retains airfoil shape.

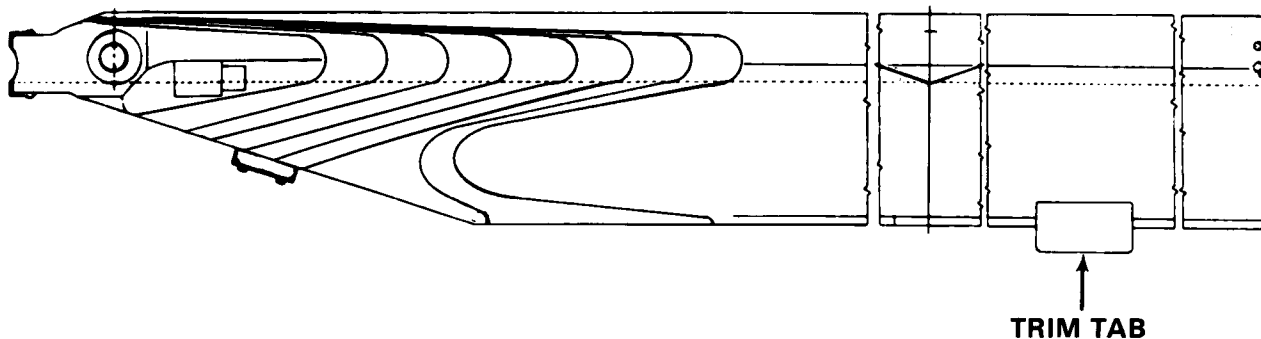
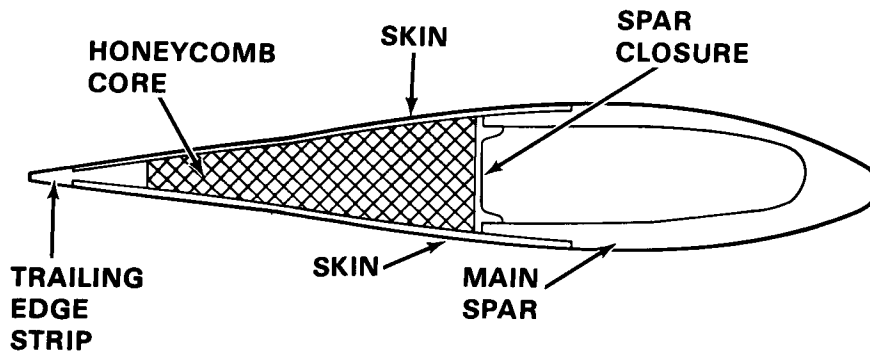



THE TAIL ROTOR DRIVE TRAIN extends from the free-wheeling unit to the tail rotor gearbox. The drive train is made up of eight individual drive shafts: three short ones extending from the free-wheeling unit to the tail boom, and one short shaft and four longer, interchangeable shafts extending along the top of the tail boom. The engine oil cooler blower is installed on and driven by the second shaft from the free-wheeling unit. The first two shafts are steel and the remainder are aluminum alloy.

Steel laminated flexible couplings requiring no lubrication are used to connect the individual shafts to each other and to the tail rotor gearbox. Bearing hangers support and maintain the drive shaft alignment.

The tail rotor gearbox contains two spiral bevel gears which change the direction of drive 90° and provide a speed reduction of 2.35 to 1.0. It has its own, self-contained lubrication system with a capacity of 0.1 liter (0.375 U.S. pints). The gearbox assembly includes a breather-type filler cap, an oil level sight gauge, and a combination electrical chip detector and self-closing valve. The self-closing valve makes it possible to check the electric chip detector for metal particles without draining oil from the gearbox. The

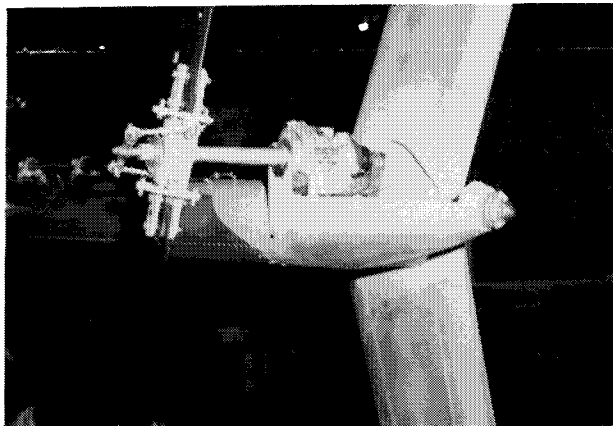

Tail Rotor Gearbox

02279

self-closing valve also serves as a drain plug for gearbox oil.

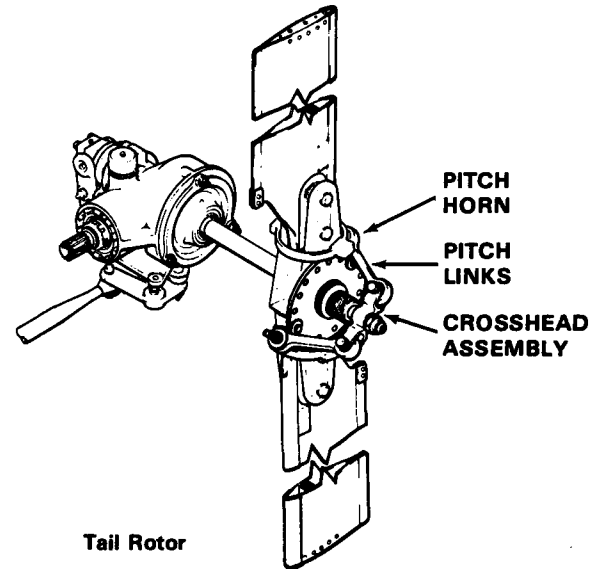

Quick, sure directional control is provided by the two bladed, semi-rigid tail rotor mounted on the left side of the tail boom.

The tail rotor is a delta-hinge type with two interchangeable blades and a changeable pitch controlled by the directional pedals.

The tail rotor blade is an all-metal bonded assembly composed of stainless-steel skins over a honeycomb core. Two spherical bearings permit the pitch changes.

The tail rotor hub has an aluminum-alloy yoke and a stainless-steel trunnion. Each rotor blade is retained by two bolts. The pitch horn is a ring with a center cross-piece that bolts onto the root end of the blade. A pitch link connects the pitch horn to a crosshead assembly mounted on the tail rotor control tube outboard of the hub.



THIS IS AN UNCONTROLLED DOCUMENT. THE DATA IS PRESENTED FOR GENERAL INFORMATION ONLY. SOME INFORMATION HAS BEEN SUPERCEDED SINCE ORIGINAL PUBLICATION. PLEASE REFER TO THE CURRENT PRODUCT SPECIFICATION BOOKLET FOR UP-TO-DATE STANDARD EQUIPMENT LIST & KIT WEIGHTS, PERFORMANCE, AND DIRECT OPERATING COST.

BELL 206B JETRANGER III

The pitch links are nonadjustable and use non-lubrication bearings.



020158



003515

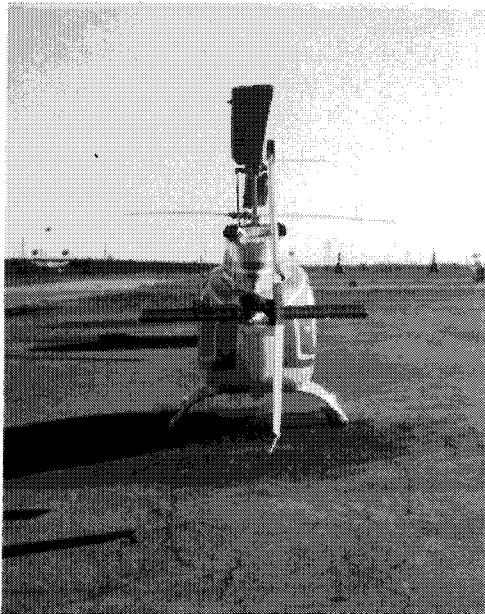

02279



02279



THE ELECTRICAL SYSTEM

is 28-volt dc, single-conductor. All circuits are single wire with a common "negative" ground. Primary electrical power is supplied by a 30-volt, 150-ampere air-cooled starter/generator (derated to 105 amperes). It serves the dual function of starter and main generator. An electronic starter/generator control unit functions as a regulator.

In the event of failure of the starter/generator, essential dc loads are supplied by the secondary system - a 24-volt, 13-ampere-hour, nickel-cadmium battery installed in the nose section. The capacity of the battery is 10 ampere-hours at the 5-hour discharge rate. At 65% power the battery will permit six starts at 32°C (90°F) and will perform a start down to -32°C (-25°F).

The engine may be started from battery power or by connecting an external 28-volt dc power source to the power receptacle in the nose.

The ignition system consists of a single igniter plug and an ignition exciter box, provided by the engine manufacturer. The engine starter switch is located on the pilot's collective control stick.

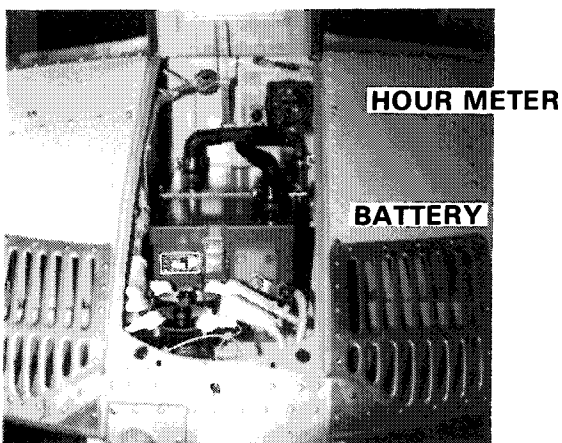

Battery Compartment

02279

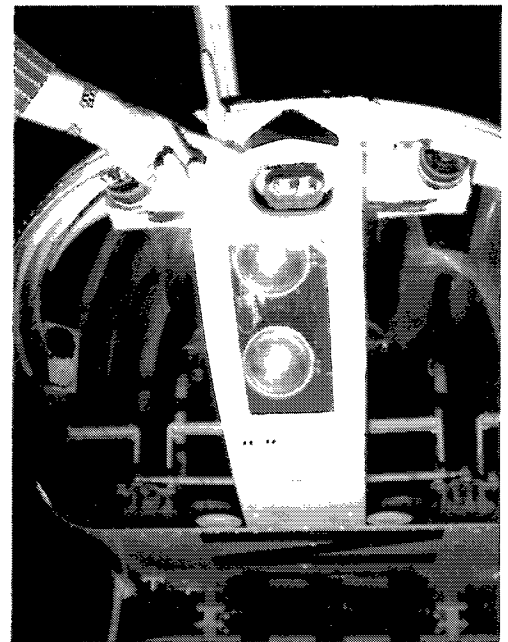

JetRanger Nose

008983

The battery temperature is monitored by thermal switches mounted under the battery case. A caution light indicating that the battery temperature is above normal and a light indicating the battery temperature is excessively high are provided in the caution panel. The pilot, warned of a battery malfunction, can disconnect the battery from the electrical system.

The standard JetRanger includes complete internal and external lighting

All instruments on the instrument panel have integral white lights supplied by 5-volt dc power. All other lighting is 28-volt dc white lighting. A rheostat in the roof panel controls the light intensity.

Three position lights are installed: one on either side of the horizontal stabilizer and one on the end of the tail boom. A red anticollision strobe light is located on top of the tail fin.

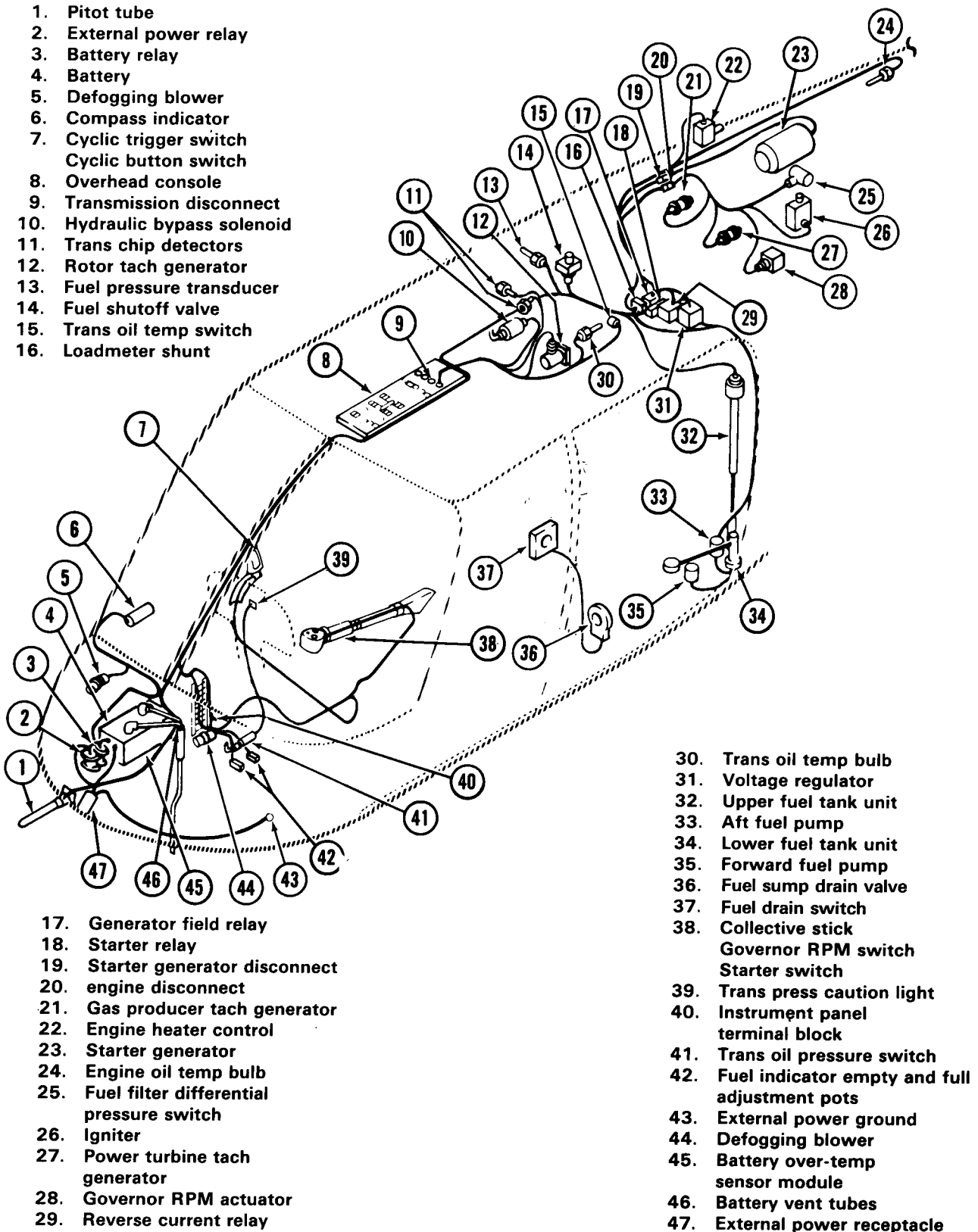

- 1. Pitot tube
- 2. External power relay
- 3. Battery relay
- 4. Battery
- 5. Defogging blower
- 6. Compass indicator
- 7. Cyclic trigger switch
- 8. Cyclic button switch
- 9. Overhead console
- 10. Transmission disconnect
- 11. Hydraulic bypass solenoid
- 12. Trans chip detectors
- 13. Rotor tach generator
- 14. Fuel pressure transducer
- 15. Fuel shutoff valve
- 16. Trans oil temp switch
- 17. Loadmeter shunt

- 30. Trans oil temp bulb
- 31. Voltage regulator
- 32. Upper fuel tank unit
- 33. Aft fuel pump
- 34. Lower fuel tank unit
- 35. Forward fuel pump
- 36. Fuel sump drain valve
- 37. Fuel drain switch
- 38. Collective stick Governor RPM switch Starter switch
- 39. Trans press caution light
- 40. Instrument panel terminal block
- 41. Trans oil pressure switch
- 42. Fuel indicator empty and full adjustment pots
- 43. External power ground
- 44. Defogging blower
- 45. Battery over-temp sensor module
- 46. Battery vent tubes
- 47. External power receptacle

Electrical installation

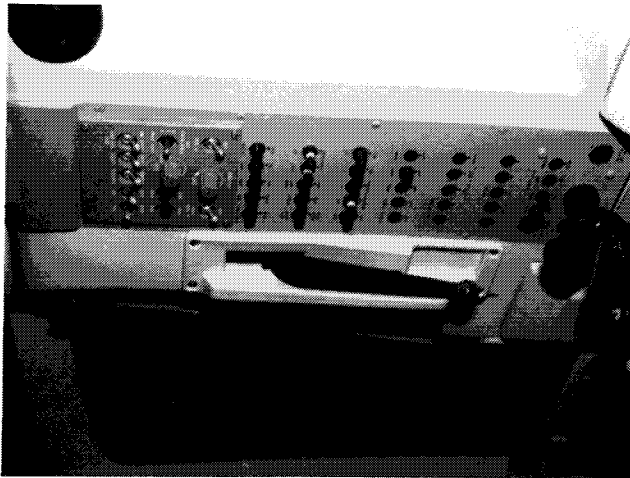

Utility Light
Shown with Optional Rotor Brake

02395



Radio Pedestal, Left Side

02272

A utility light with a separate light intensity control is mounted near the top of the vertical control tunnel between the pilot and forward passenger seats. The light can be directionally adjusted in its mounting or it can be removed and held by hand. A coiled electrical cord allows the light to be moved anywhere in the crew compartment.

Two 250-watt ground-adjustable, landing lights are mounted in the nose section. Switches for the position lights and anticollision light are located in the overhead console. The landing light "ON-OFF" switch is installed on the pilot's collective control stick.

An auxiliary 28-volt dc outlet is located on the left side of the pedestal just forward of the seat.

On delivery, the JetRanger will contain the appropriate manuals, covers for turbine exhausts, turbine air inlets and the pitot tube, a first aid kit, keys, a flight manual bag, a pair of ground handling wheels and a main rotor tiedown.

Add fuel and a pilot and it is ready to go.



THIS IS AN UNCONTROLLED DOCUMENT. THE DATA IS PRESENTED FOR GENERAL INFORMATION ONLY. SOME INFORMATION HAS BEEN SUPERCEDED SINCE ORIGINAL PUBLICATION. PLEASE REFER TO THE CURRENT PRODUCT SPECIFICATION BOOKLET FOR UP-TO-DATE STANDARD EQUIPMENT LIST & KIT WEIGHTS, PERFORMANCE, AND DIRECT OPERATING COST.

BELL 206B JETRANGER III

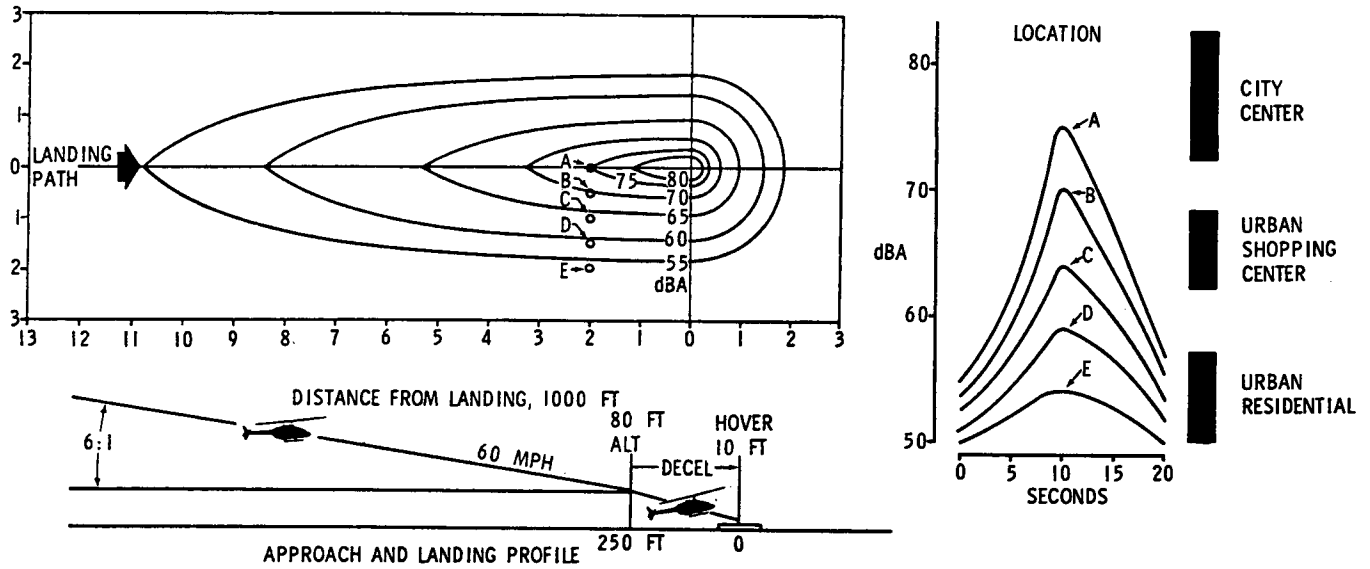

This would be appropriate time to discuss helicopter noise. The measurements taken during a typical approach and landing of the JetRanger are shown on the above diagram. These measurements, in decibels, can be directly related to time. The curves on the right illustrate the duration in seconds.

in order to be more meaningful, some comparisons have been added to show typical noise levels within the city.



001841

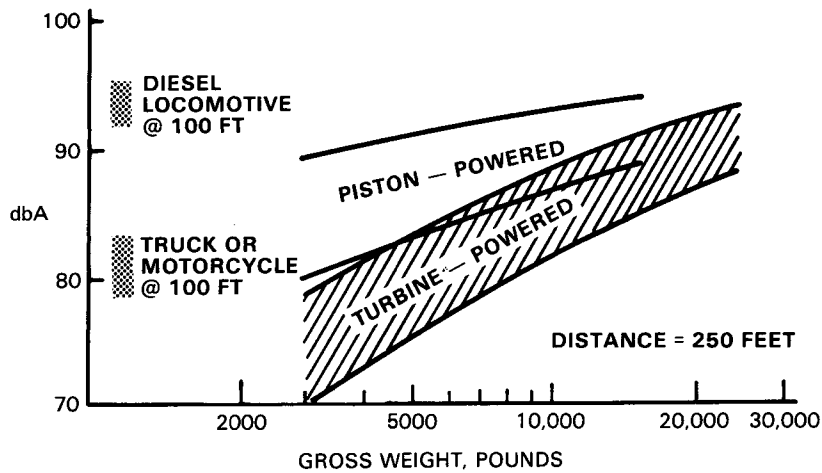

TREND OF HELICOPTER NOISE LEVELS (dbA UNITS)

When you start operating a JetRanger in new territory, you add a new spectrum of sound to the usual noise environment. If that territory is a municipality, thousands of people will hear the new sounds and know where they are coming from.

How they will react depends upon many complex physical, economic, and psychological factors, but one thing is certain: They will react strongly, adversely, and actively if the sound is too irritating, if it represents something that seems to threaten their safety and well-being, or if they cannot see how the noisemaker benefits them.

Although it is up to the operator to educate the public about the safety and usefulness of the helicopter -- the pilot can make the public less hostile to the helicopter (and to the operator's arguments about its safety and community service) by flying in such a way as to make the sound of his aircraft as nonirritating as possible.

Figure 1 shows the trend of helicopter noise levels and where the light helicopter fits into the overall noise picture. The units of the vertical

scales represent, to some extent, the degree to which a sound will annoy the average human listener.

We can't say what sound level will make the housewife, school teacher, or hospital patient complain to the authorities. Instead, we show on the figures the sound level of a diesel locomotive and a truck or motorcycle. You can compare this with the sound of the helicopter and draw your own conclusions.

Notice that the noise level of a light helicopter is a function of the type of power plant. Turbine-powered helicopters are quieter than piston-powered ones with unmuffled engine exhausts and produce sounds no louder than those of familiar surface transportation vehicles.

Notice also that the noise level of a helicopter at a given gross weight covers a range. This is true not only for helicopters in general, but also for a particular helicopter. What you need to know is how you can fly that helicopter, given a certain gross weight, in the lower portion of this range of sound levels -- at least when you are flying near people whom noise might bother.

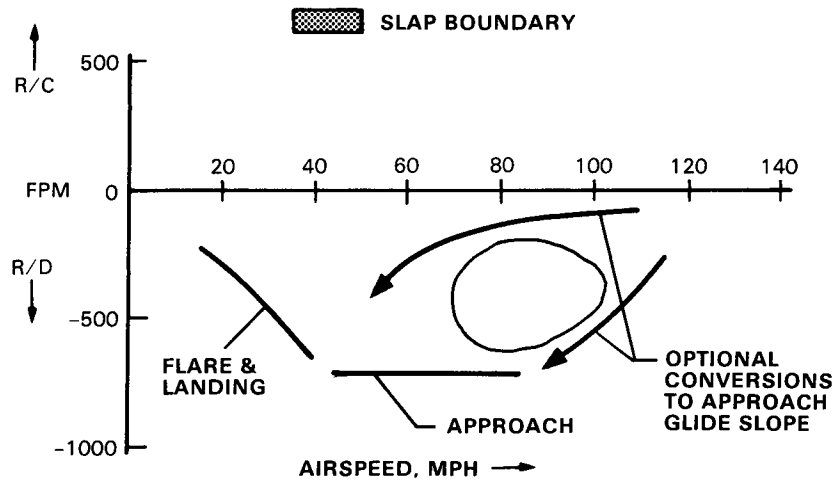

NOISE-ABATEMENT FLIGHT TECHNIQUE — LIGHT HELICOPTER

The following notes discuss conditions which produce the higher noise levels during the operation of the JetRanger and describe flight techniques which will help to avoid them.

How to minimize noise

In general, you can eliminate the most offensive sounds of the 206 helicopter by keeping it out of the slap region shown in Figure 2. This is not always possible, of course, and when the slap regions cannot be avoided, they should be flown through as quickly as possible. There are also other methods of reducing helicopter noise, and you should use them when you can, whether you are flying in a slap region or not.

Routes and airspeeds

1. Fly at highest practical altitude during approach to metropolitan areas.
2. Select route into terminal over least populated area.
3. Follow major thoroughfares or railway roadbeds.
4. Avoid flying low over residential and other densely populated areas.

5. If you must fly over such areas, maintain a cruise speed of approximately 110 mph.

6. Select the final approach route with due regard to the type of neighborhood surrounding the terminal and the neighborhood's sensitivity to noise. Assess this sensitivity beforehand for each terminal. Some of the guidelines are:

- a. Approach keeping the terminal between the helicopter and the most noise-sensitive building or area.
- b. If the terminal is surrounded by noise-sensitive areas, approach at the steepest practical glide slope.
- c. Avoid flying directly over hospitals, nursing homes, schools, and other highly noise-sensitive facilities.

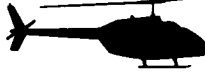

Noise-abatement approach and landing

1. When commencing approach, follow one of these two procedures:
 - Establish a rate-of descent of at least 500 ft/min before reducing airspeed, then reduce airspeed while increasing rate-of-descent to at least 800 ft/min, or
 - Hold rate-of-descent to less than 200 ft/min while reducing airspeed to about 65 mph, then increase rate-of-descent to at least 800 ft/min.
2. At a convenient airspeed between 60 and 90 mph, set up approach glide slope while maintaining the 800 ft/min or more rate-of-descent.
3. Increase rate-of-descent if the main rotor tends to slap, or if you want a steeper glide slope.
4. Approaching the flare, reduce airspeed to below 70 mph before decreasing rate-of-descent.
5. Execute normal flare and landing, decreasing rate-of-descent and airspeed appropriately.

The basic difference between this approach technique and a normal one is that this one avoids the slap regime. Both procedures give approximately the same airspeed during the approach, with the quieter technique using a glide slope which is a few degrees steeper.

Once the pilot has transitioned from cruise to the approach glide slope, he can tailor his airspeed and rate of descent to fit local conditions, avoid unsafe regimes, and still guarantee minimum noise.

Departure

Takeoffs are reasonably quiet operations, but you can limit the total ground area exposed to helicopter sound by using a high rate-of-climb and making a very smooth transition to forward flight. Your departure route should take you over areas which are the least sensitive to noise.

Maneuvers

Avoid rapid, high g turns, as a general rule. When the flight operation requires turns, perform them smoothly. Be smooth in all other maneuvers, also.

THIS IS AN UNCONTROLLED DOCUMENT. THE DATA IS PRESENTED FOR GENERAL INFORMATION ONLY. SOME INFORMATION HAS BEEN SUPERCEDED SINCE ORIGINAL PUBLICATION. PLEASE REFER TO THE CURRENT PRODUCT SPECIFICATION BOOKLET FOR UP-TO-DATE STANDARD EQUIPMENT LIST & KIT WEIGHTS, PERFORMANCE, AND DIRECT OPERATING COST.

PUBLISHERS NOTICE

The data presented in this document is **GENERAL** in nature, and has been compiled from Bell Helicopter Textron Inc. [**BHTI**] publications including but not limited to; The Model 206B3 Rotorcraft Flight Manual & Manufacturers Data, The Model 206B3 Maintenance Manual, The Model 206B3 Illustrated Parts Catalog, and **BHTI** Training Academy Model 206B3 Pilot and Mechanic Course Manuals.

This document is intended for the use of **BHTI Sales Personnel** and for **prospective customers** as an aid in defining the features and benefits of the Bell Model 206B3 .

This document contains **proprietary material** of **BHTI**. Disclosure, reproduction, or use of any material in this document by persons **other than BHTI employees, and BHTI Independent Representatives [International Dealers]** is forbidden without written permission from **BHTI**.

The **PHOTOGRAPHS** and **DRAWINGS** used in this book are for **illustration** only, and may differ from the actual aircraft, as the **BHTI** continuing product improvement process causes some components, specifications, and procedures to be changed or replaced.

For the **MOST CURRENT** Model 206B3 tabular data, standard equipment list, optional equipment kits, and performance and fuel flow charts refer to the Bell 206B3 Technical Information Booklet. For performance and operational limitations for **actual mission planing** reference must **ALWAYS** be made to the FAA Approved Rotorcraft Flight Manual.

THIS IS AN UNCONTROLLED DOCUMENT. THE DATA IS PRESENTED FOR GENERAL INFORMATION ONLY. SOME INFORMATION HAS BEEN SUPERCEDED SINCE ORIGINAL PUBLICATION. PLEASE REFER TO THE CURRENT PRODUCT SPECIFICATION BOOKLET FOR UP-TO-DATE STANDARD EQUIPMENT LIST & KIT WEIGHTS, PERFORMANCE, AND DIRECT OPERATING COST.

SECTION TWO

DESCRIPTIVE SUMMARY

BELL 206B, JETRANGER III



THIS IS AN UNCONTROLLED DOCUMENT. THE DATA IS PRESENTED FOR GENERAL INFORMATION ONLY. SOME INFORMATION HAS BEEN SUPERCEDED SINCE ORIGINAL PUBLICATION. PLEASE REFER TO THE CURRENT PRODUCT SPECIFICATION BOOKLET FOR UP-TO-DATE STANDARD EQUIPMENT LIST & KIT WEIGHTS, PERFORMANCE, AND DIRECT OPERATING COST.



SYNOPSIS

The JetRanger III is a fully equipped, light, utility helicopter, complete -- ready to fly.

Single pilot, VFR day or night.

Deluxe appointments for the comfortable transport of five:

-- pilot and passenger forward

-- three passengers in the passenger compartment, forward facing.

Four seats quickly removable to accept up to 1.7 cubic meters (60 ft³) of cargo.

Choice of exterior and interior color combinations.

The JetRanger III is powered by a single Allison 250-C20J free-turbine engine:

Take-off power -- 313 kW (420 shp)

Usable fuel capacity is 344 liters (91 US gal) weighing 280 kg (619 lb)*

The equipped weight of the standard JetRanger III is 742 kilograms (1635 pounds).**

Maximum gross weights are:

1452 kilograms (3200 lb) for internal loads on standard, high skids or emergency floats.

1520 kilograms (3350 lb) for external loads (up to 680 kg (1500 lb) on the hook).

Fully certified avionics and optional equipment are available to fulfill special mission requirements.

*Using Jet A fuel at 0.815 kg/l (6.8 lb/gal).

**The published weight includes all the equipment described in the standard configuration, and 5.9 kilograms (13lb) of oil. It does not include ballast because ballast is a function of installed optional equipment.



DESCRIPTIVE SUMMARY

GENERAL DESCRIPTION

Five place	1-4
Polyurethane finish	1-5
Three basic designs, each in 3 colors	
Single pilot	1-6

INTERIOR

Comfortable personnel transport	1-6
Individual seats	
Deluxe interior	
Seat and seat-back frames Fabric/vinyl -- Adjustable lumbar support	1-6
-- 4 colors	1-7
Carpeted	1-8
Ample foot room	
Door restraining straps	
Accent door stripes	
Metal door sills	
Optional Ash Trays	1-9
Five seat belts	
Two inertia-reel double-strap harnesses	
Three inertia-reel shoulder straps	
Soundproofing	1-10
Four large doors	
Four large sliding windows	1-11
Rear windows bulged	
Blue tinted acrylic	
Recessed handles outside	1-12
D-ring handles inside	

Door locks	
Rain gutters	1-13

PILOT'S STATION

Right front seat	1-14
Efficient, comfortable, roomy	
Instruments, controls central	
All-around visibility	
Two pockets for flight documents	
Conventional flight controls	1-15
Cyclic	1-16
Comfortable grip	
Radio switches	
Collective	
Starter	
RPM adjustment	
Landing light switch	
Automatic throttle	
Friction control	
Directional pedals	1-17
Adjustable for length	
Vertical control tunnel	
Hydraulic boost	
Cyclic, collective	
No feed back	
Swashplate	1-18
Unboosted directional pedals	1-19

HYDRAULIC SYSTEM

Roof-mounted	1-19
Self-contained	
Transmission driven pump	1-20
Relief valves, filters filters	
Visual "Clogging" warnings	
Can be electrically isolated and flight continued	
Separate reservoir	
Quick-disconnects for maintenance	



JETRANGER

Easy to fly	1-21
Comfortable	
Good maintenance characteristics	

THE INSTRUMENT PANEL

Basic flight and engine instruments	1-22
Compass	
Outside Air Temperature Gauge	
Hinged panel for maintenance	
Integral white lighting	
Pitot tube static ports	
Airspeed in knots and mph	
Low RPM Horn Mute	1-23
TOT Light Test	1-24
Inclinometer	
Altimeter	
Clock	
Fuel quantity gauge	
Fuel pressure/loadmeter	
Space saving mix of gauges, caution lights	
Dual tachometer	
Torquemeter	
Transmission oil pressure/temperature	
Engine oil pressure/temperature	
Engine oil pressure/temperature	
Gas producer tachometer	
Turbine outlet temperature gauge with red warning light	

CAUTION PANEL

20 module, dimmable lighting	1-25
11 monitors, 9 spares	
Light test button	

OVERHEAD CONSOLE

Electric switches, controls and Circuit Breakers	1-27
Airspeed limit placard	

RADIO PEDESTAL

Sloping design	1-28
Optional Ash Tray	
Switching panel	

PORTABLE FIRE EXTINGUISHER 1-28

AIRFRAME

Fuselage	1-29
Forward section	
Intermediate section	
Tail boom	
Cowlings	

FORWARD SECTION

Nose	1-29
Crew compartment	
Passenger compartment	
Aluminum honeycomb structure	1-30
Integral seat benches	
Two rugged bulkheads	
Vertical control tunnel	
Longitudinal roof beams	
Landing light/battery compartments	
Ventilation grilles	
Fresh air ventilation	
Ram air, blower assisted	

INTERMEDIATE SECTION

Semimonocoque structure	1-31
Engine deck	
Baggage compartment	
Kick-in step	1-32
Equipment compartment	
Manufacturer's data plate	1-33



TAIL BOOM

Tail fin, tail skid	1-34
Fixed horizontal stabilizer	
Tail rotor	
Tail rotor drive train	

COWLINGS AND FAIRINGS

Inspection ports	1-35
Snow deflector provisions	1-36

LANDING GEAR

Tubular skid type	1-33
Fairings	
Ground handling wheels	
Tow rings	
Skid shoes	

FINAL ASSEMBLY

Tie down fittings	1-38
Hoisting	1-40
Leveling	

DYNAMIC COMPONENTS

Allison Model 250-C20J gas turbine engine 313 kW (420 shp)	1-41
Installation, fire walls	
Free wheeling unit	1-42
Modular construction	1-43
Compressor	
Combustion section	
Turbine	
Power & accessories gear train	
Anti-icing system	1-44
Compressor wash system	
Hour meter	1-45
Tot Light Reset	
Start counter	
Engine operating principles	
Allison 250-C20R4 Production Option	1-47

ENGINE OIL SYSTEM

Dry sump system	1-51
Oil reservoir	
Fan cooled	
Magnetic chip detector	

FUEL SYSTEM

Single cell	1-52
344 liters (91US gal)	
Engine driven pump	
Two electric submerged boost pumps	
Fuel filter	
Fuel controls	
Shut-off	
Fuel sump drain	

TRANSMISSION

A-frame mounting	1-55
Spiral bevel and planetary	
Self contained lubrication	1-57
Transmission driven pump	
Filter	
1 chip detector in transmission	1-58
1 in free wheeling unit	

MAIN ROTOR

Mast	1-60
Underslung, feathering-axis hub	
Semi-rigid, teetering rotor	
High inertia system	
Flap restraint	1-61
All metal bonded blades	1-62
Trim tabs	



THIS IS AN UNCONTROLLED DOCUMENT. THE DATA IS PRESENTED FOR GENERAL INFORMATION ONLY. SOME INFORMATION HAS BEEN SUPERCEDED SINCE ORIGINAL PUBLICATION. PLEASE REFER TO THE CURRENT PRODUCT SPECIFICATION BOOKLET FOR UP-TO-DATE STANDARD EQUIPMENT LIST & KIT WEIGHTS, PERFORMANCE, AND DIRECT OPERATING COST.

**BELL 206B
JETRANGER III**

TAIL ROTOR

Drive train of 8 shafts	1-63
Oil cooler blower	
Flexible couplings	
Bevel gear reduction	
Self contained lubrication	
Electric chip detector	
Two bladed delta hinged rotor	
Stainless steel blades	

ELECTRICAL SYSTEM

28 volt	1-65
30 volt 150 amp starter generator	
Voltage regulator	
13 amp/h nickel cadmium battery	
Ignition system	
External power receptacle	
Battery temperature monitor	
Internal & instrument lighting	
Position lights	
Strobe	
Two landing lights	1-67
28 volt auxiliary power receptacle	
Cockpit utility light	

MISCELLANEOUS*

Manuals	1-67
Keys	
First aid kit	
Inlet covers	
Ground handling wheels	

NOISE

External noise charts	1-68
--------------------------	------

*Not included in the published equipped weight

THIS IS AN UNCONTROLLED DOCUMENT. THE DATA IS PRESENTED FOR GENERAL INFORMATION ONLY. SOME INFORMATION HAS BEEN SUPERCEDED SINCE ORIGINAL PUBLICATION. PLEASE REFER TO THE CURRENT PRODUCT SPECIFICATION BOOKLET FOR UP-TO-DATE STANDARD EQUIPMENT LIST & KIT WEIGHTS, PERFORMANCE, AND DIRECT OPERATING COST.

THIS IS AN UNCONTROLLED DOCUMENT. THE DATA IS PRESENTED FOR GENERAL INFORMATION ONLY. SOME INFORMATION HAS BEEN SUPERCEDED SINCE ORIGINAL PUBLICATION. PLEASE REFER TO THE CURRENT PRODUCT SPECIFICATION BOOKLET FOR UP-TO-DATE STANDARD EQUIPMENT LIST & KIT WEIGHTS, PERFORMANCE, AND DIRECT OPERATING COST.

SECTION THREE

OPTIONAL EQUIPMENT

BELL 206B, JETRANGER III



THIS IS AN UNCONTROLLED DOCUMENT. THE DATA IS PRESENTED FOR GENERAL INFORMATION ONLY. SOME INFORMATION HAS BEEN SUPERCEDED SINCE ORIGINAL PUBLICATION. PLEASE REFER TO THE CURRENT PRODUCT SPECIFICATION BOOKLET FOR UP-TO-DATE STANDARD EQUIPMENT LIST & KIT WEIGHTS, PERFORMANCE, AND DIRECT OPERATING COST.

PUBLISHERS NOTICE

The data presented in this document is **GENERAL** in nature, and has been compiled from Bell Helicopter Textron Inc. [**BHTI**] publications including but not limited to; The Model 206B3 Rotorcraft Flight Manual & Manufacturers Data, The Model 206B3 Maintenance Manual, The Model 206B3 Illustrated Parts Catalog, and **BHTI** Training Academy Model 206B3 Pilot and Mechanic Course Manuals.

This document is intended for the use of **BHTI Sales Personnel** and for **prospective customers** as an aid in defining the features and benefits of the Bell Model 206B3 .

This document contains **proprietary material** of **BHTI**. Disclosure, reproduction, or use of any material in this document by persons **other than BHTI employees, and BHTI Independent Representatives [International Dealers]** is forbidden without written permission from **BHTI**.

The **PHOTOGRAPHS** and **DRAWINGS** used in this book are for **illustration** only, and may differ from the actual aircraft, as the **BHTI** continuing product improvement process causes some components, specifications, and procedures to be changed or replaced.

For the **MOST CURRENT** Model 206B3 tabular data, standard equipment list, optional equipment kits, and performance and fuel flow charts refer to the Bell 206B3 Technical Information Booklet. For performance and operational limitations for **actual mission planing** reference must **ALWAYS** be made to the FAA Approved Rotorcraft Flight Manual.



SECTION THREE

CONTENTS

ALTERNATE LANDING GEARS

High Skid	3-1
Emergency Floats	3-5

CONTROLS AND ENGINE ACCESSORIES

Dual Controls	3-13
Rotor Brake	3-15
Particle Separator	3-19
Snow Baffles	3-21
Automatic Engine Re-Ignition	3-23

INSTRUMENTS/ELECTRICAL/AVIONICS

Flight Instrument Group	3-27
VHF Communication/Navigation Transceiver	3-31
Course Deviation Indicator	3-37
Automatic Direction Finder	3-41
Transponder	3-45
Auxiliary Battery	3-49
Heavy Duty Battery	3-51

INTERIORS AND ENVIRONMENT

Custom Deluxe Interiors	3-53
Mesh Seats	3-57
Special Interiors	3-61
Custom Soundproofing Blankets	3-63
Bleed Air Heater	3-65
Environmental Control System	3-71

MISCELLANEOUS

Cargo Hook	3-79
Litters	3-83
Hoist	3-91
Hoist Cable Guard	3-97
Cargo/Service Platform	3-99
Maintenance Step	3-101
Camera Access Door	3-103



INTRODUCTION

Bell maintains a wide variety of optional kits for the 206B JetRanger III. Most of these are suitable for installation either at the factory or at the customer's facility. A few require installation during initial production.

Optional kits are not always compatible with each other: some require other kits, such as high skid gear, before they can be used effectively.





THIS IS AN UNCONTROLLED DOCUMENT. THE DATA IS PRESENTED FOR GENERAL INFORMATION ONLY. SOME INFORMATION HAS BEEN SUPERCEDED SINCE ORIGINAL PUBLICATION. PLEASE REFER TO THE CURRENT PRODUCT SPECIFICATION BOOKLET FOR UP-TO-DATE STANDARD EQUIPMENT LIST & KIT WEIGHTS, PERFORMANCE, AND DIRECT OPERATING COST.

BELL 206B JETRANGER III

HIGH SKIDS

BELL KIT NO. 206-706-031-001

The purpose of the High Skids kit is to provide greater ground clearance to facilitate operations in rough terrain, tall grass, and other adverse ground conditions. It also enables fitted, underslung loads to be carried, such as chemical tanks for agricultural applications or water tanks for forest fire-fighting.

The gear is similar in design to the standard skid landing gear, but it adds approximately 33 centimeters (13 inches) to the standard ground clearance of 30 centimeters (12 inches). The tail high attitude of the gear provides even greater tail clearance from approximately 46 to 90 centimeters (18 to 36 inches).



308698



THIS IS AN UNCONTROLLED DOCUMENT. THE DATA IS PRESENTED FOR GENERAL INFORMATION ONLY. SOME INFORMATION HAS BEEN SUPERCEDED SINCE ORIGINAL PUBLICATION. PLEASE REFER TO THE CURRENT PRODUCT SPECIFICATION BOOKLET FOR UP-TO-DATE STANDARD EQUIPMENT LIST & KIT WEIGHTS, PERFORMANCE, AND DIRECT OPERATING COST.

BELL 206B JETRANGER III

The kit consists of fore and aft crosstubes, skid tubes with replaceable skid shoes, four fuselage-mounted cabin steps and the attachment hardware.

The ground handling wheels, supplied with the basic helicopter, are installed and used in the same manner as with the standard gear.

Fairings are not provided for this utility configuration.

The high skid gear fits the standard fuselage attachment points and can be installed and removed with ease.

The weight increase with high skids installed is 8.0 kilograms (17.6 pounds). Gross weight is approved to 1452 kilograms (3200 pounds) for internal loads, and 1520 kilograms (3350 pounds) for external loads.

If the ground handling wheels are stowed, add 11.3 kilograms (25 pounds).

Flight procedures are contained in the Flight Manual Supplement.

Installation and Maintenance Instructions are contained in Bell Service Instruction 206-22.

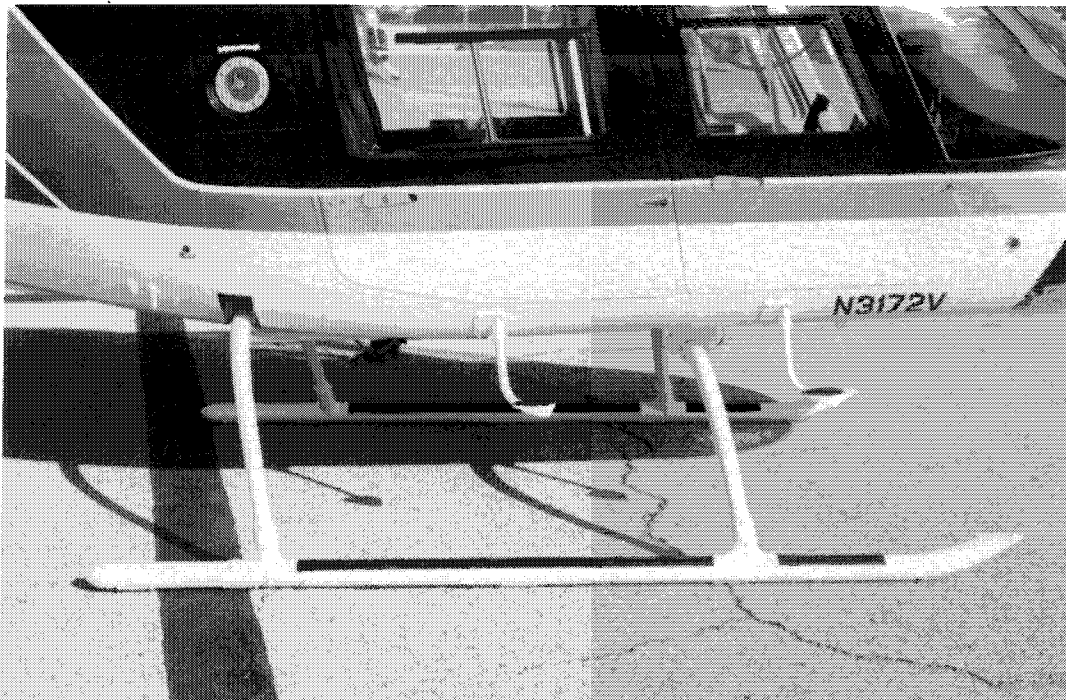

FUSELAGE MOUNTED STEP

025272

THIS IS AN UNCONTROLLED DOCUMENT. THE DATA IS PRESENTED FOR GENERAL INFORMATION ONLY. SOME INFORMATION HAS BEEN SUPERCEDED SINCE ORIGINAL PUBLICATION. PLEASE REFER TO THE CURRENT PRODUCT SPECIFICATION BOOKLET FOR UP-TO-DATE STANDARD EQUIPMENT LIST & KIT WEIGHTS, PERFORMANCE, AND DIRECT OPERATING COST.

BELL 206B
JETRANGER III



Dimensions in meters and (feet) measured at 1452 kilograms (3200 pounds) gross weight.

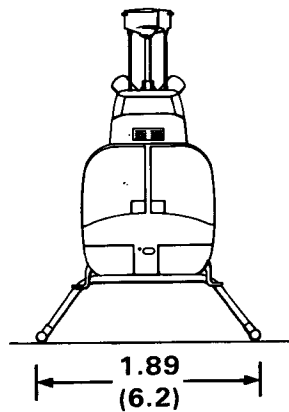
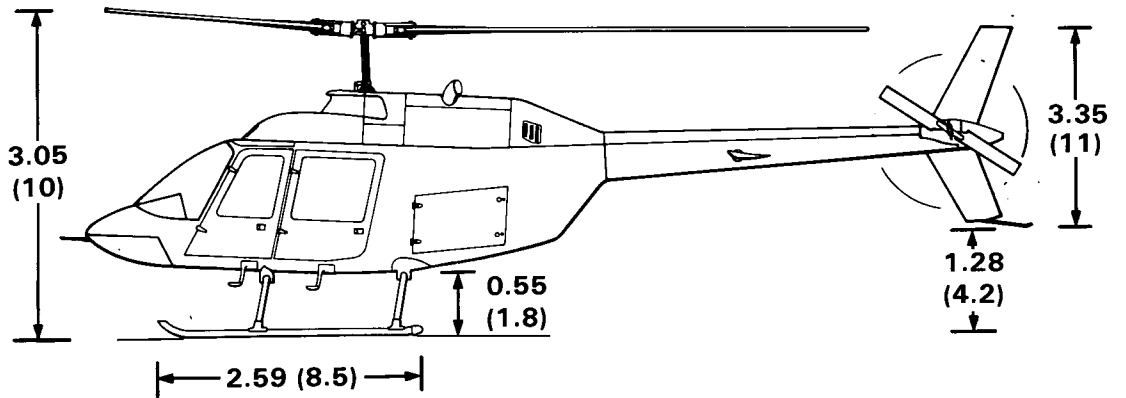



THIS IS AN UNCONTROLLED DOCUMENT. THE DATA IS PRESENTED FOR GENERAL INFORMATION ONLY. SOME INFORMATION HAS BEEN SUPERCEDED SINCE ORIGINAL PUBLICATION. PLEASE REFER TO THE CURRENT PRODUCT SPECIFICATION BOOKLET FOR UP-TO-DATE STANDARD EQUIPMENT LIST & KIT WEIGHTS, PERFORMANCE, AND DIRECT OPERATING COST.

BELL 206B JETRANGER III



025270

STANDARD GEAR AND HIGH SKIDS

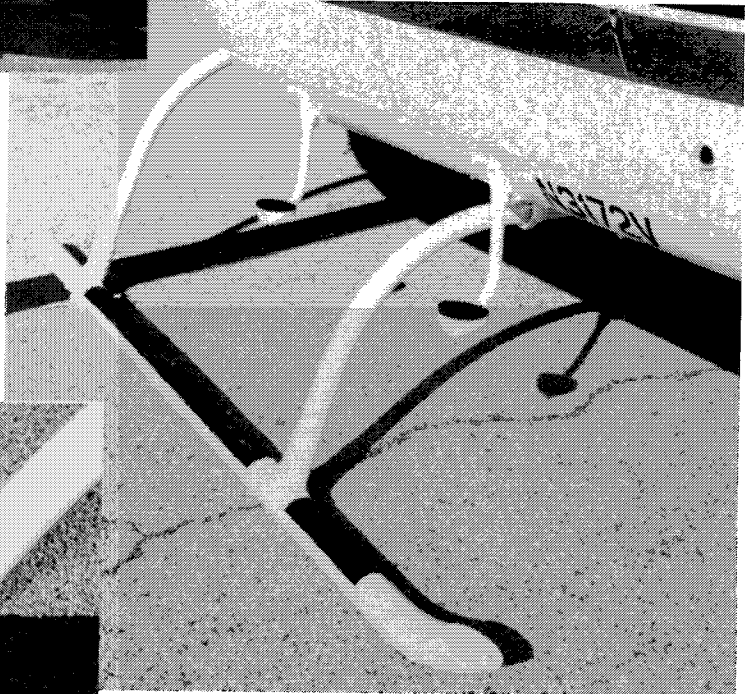

025274

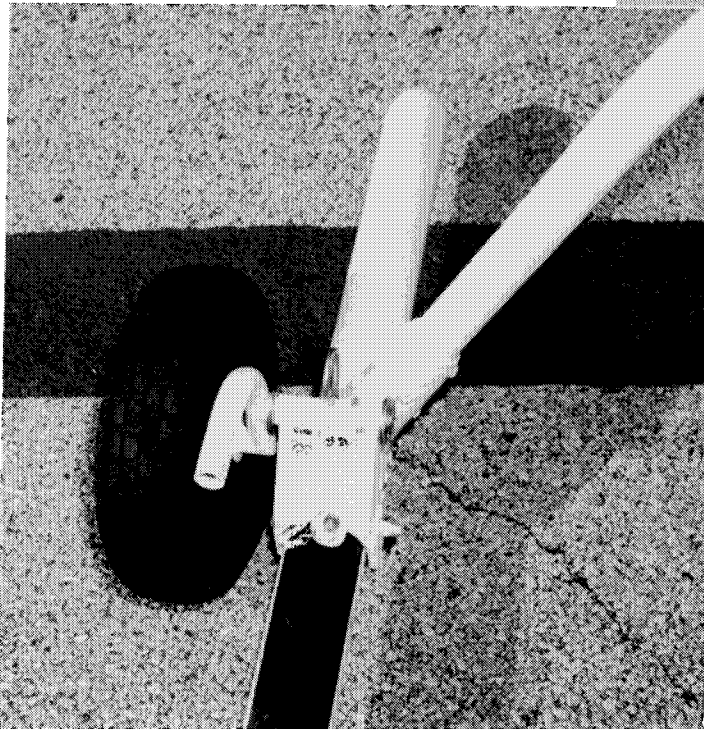

025253



EMERGENCY FLOATS

BELL KIT NO. 206-706-211-101

The purpose of the Emergency Floats kit is to provide the safety required when operations extend over water but landings on the water are not anticipated.

The floats are normally stowed.

When the arming circuit is closed, the "Float-Arm" indicator illuminates and the system is ready to be activated by a trigger switch on the pilot's collective stick.

The floats, inflated by compressed nitrogen, begin to provide buoyancy immediately and are capable of supporting the weight of the helicopter within five seconds after actuation.

The kit consists of emergency floats attached to the specially lengthened main skids, high-skid landing gear crosstubes, electrically activated inflation system with a preflight test feature, additional position lights, full length steps, and attaching hardware.

The float bags are attached three to a side. The two forward ones are single cell, the larger aft one is dual cell. Each stowed float is protected with a separate snap-close light-weight cover.

The compressed nitrogen inflation system has a single bottle mounted externally, immediately aft of the forward crosstube. The main skid protects the floats from ground contact either



025269



stowed or inflated. Each skid has five replaceable sheetmetal shoes to accommodate normal ground-contact wear.

Additional position lights prevent blackout of the normal indicators when the floats are inflated. These are located on the fuselage just forward of the front crosstube and illuminate when the landing lights are turned on.

The arming switch is mounted on the overhead console and the float test switch on the instrument panel. Two caution lights are inserted in the caution panel; one to indicate floats are armed and one for testing circuit continuity.

The standard ground handling wheels fit the emergency float gear.

The weight increase with Emergency Floats installed is 65.5 kilograms (144.4 pounds).

Maximum approved gross weight with the kit installed is 1452 kilograms (3200 pounds).

Flight procedures are contained in the Flight Manual Supplement. There are no flight restrictions in the stowed configuration.

The hoist is compatible with the Emergency Float kit when the Cable Guard Kit 206-706-214-101 is installed.

Installation and Maintenance Instructions are contained in Bell Service Instruction 206-115.

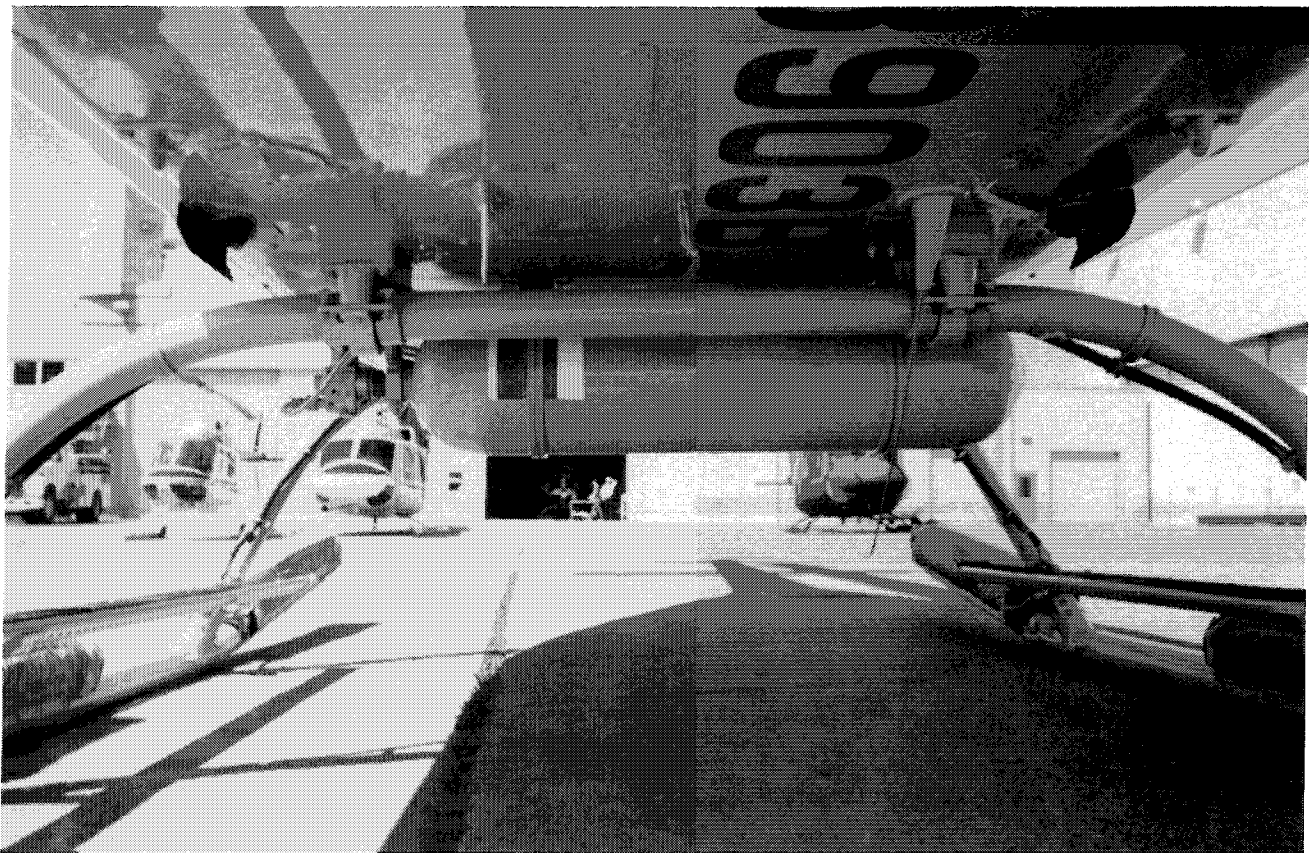



THIS IS AN UNCONTROLLED DOCUMENT. THE DATA IS PRESENTED FOR GENERAL INFORMATION ONLY. SOME INFORMATION HAS BEEN SUPERCEDED SINCE ORIGINAL PUBLICATION. PLEASE REFER TO THE CURRENT PRODUCT SPECIFICATION BOOKLET FOR UP-TO-DATE STANDARD EQUIPMENT LIST & KIT WEIGHTS, PERFORMANCE, AND DIRECT OPERATING COST.

BELL 206B JETRANGER III

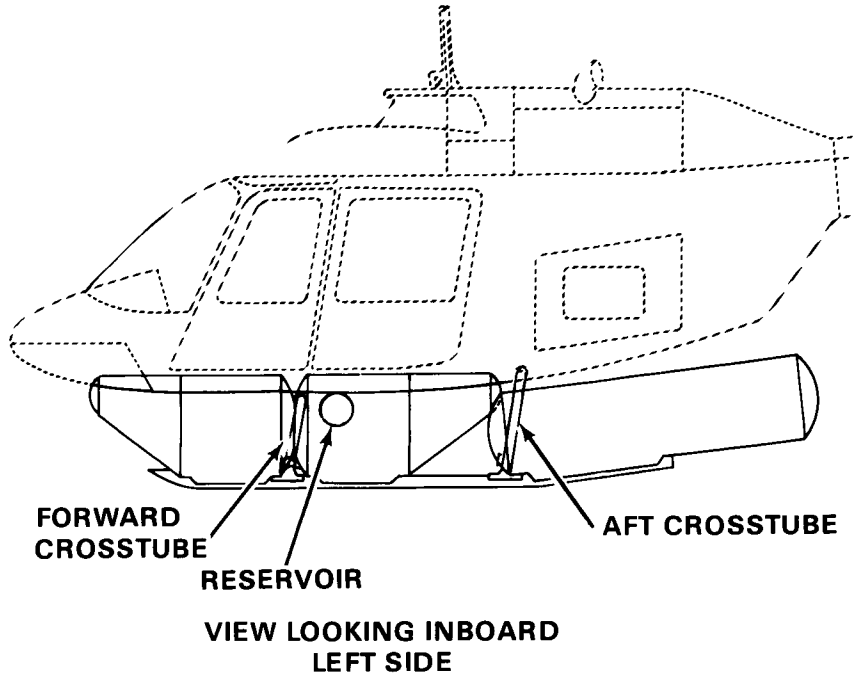
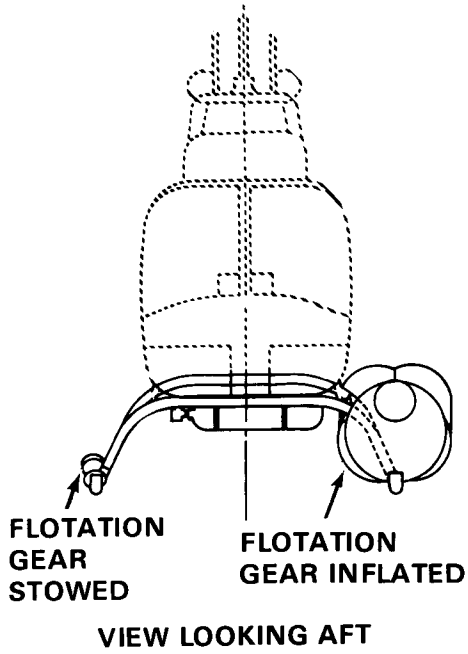

025273

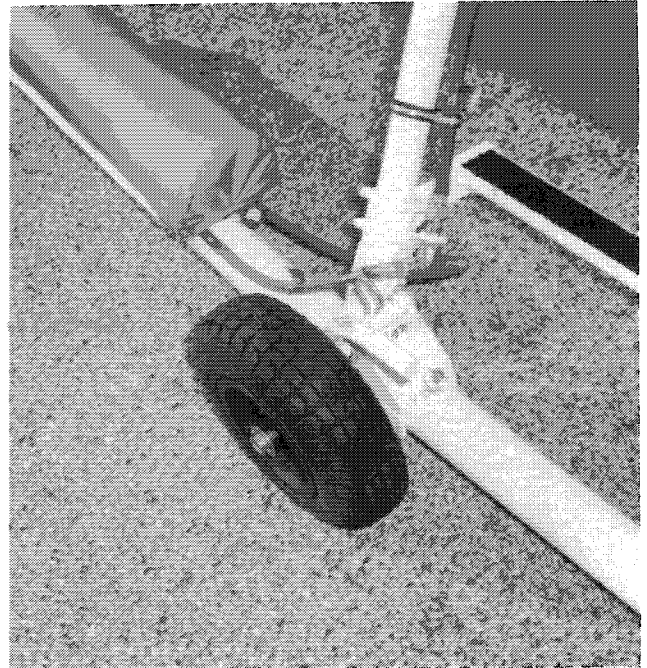

025271



THIS IS AN UNCONTROLLED DOCUMENT. THE DATA IS PRESENTED FOR GENERAL INFORMATION ONLY. SOME INFORMATION HAS BEEN SUPERCEDED SINCE ORIGINAL PUBLICATION. PLEASE REFER TO THE CURRENT PRODUCT SPECIFICATION BOOKLET FOR UP-TO-DATE STANDARD EQUIPMENT LIST & KIT WEIGHTS, PERFORMANCE, AND DIRECT OPERATING COST.

**BELL 206B
JETRANGER III**

206B fuel flows, ISA conditions with emergency floats installed.

Speeds and fuel flows are both economical cruise and maximum speed cruise.

Max Gross Weight = 1452 kilograms			
Sea Level	204 km/h	91 kg/h	114 l/h
300 meters	206 km/h	89 kg/h	110 l/h
1000 meters	211 km/h	88 kg/h	110 l/h
3000 meters	200 km/h	82 kg/h	102 l/h
Gross Weight with 144 liters of fuel = 1335 kilograms			
Sea Level	209 km/h	91 kg/h	114 l/h
300 meters	215 km/h	89 kg/h	110 l/h
1000 meters	217 km/h	88 kg/h	110 l/h
3000 meters	213 km/h	82 kg/h	102 l/h
Max Gross Weight = 3,200 lb			
Sea Level	110 kn	200 lb/h	(30 gal/h)
1000 ft	111 kn	197 lb/h	(29 gal/h)
3000 ft	114 kn	194 lb/h	(29 gal/h)
10,000 ft	108 kn	180 lb/h	(27 gal/h)
Gross Weight with 38 U.S. gallons of fuel = 2,942 lb			
Sea Level	113 kn	200 lb/h	(30 gal/h)
1000 ft	116 kn	197 lb/h	(29 gal/h)
3000 ft	117 kn	193 lb/h	(29 gal/h)
10,000 ft	115 kn	180 lb/h	(27 gal/h)



THIS IS AN UNCONTROLLED DOCUMENT. THE DATA IS PRESENTED FOR GENERAL INFORMATION ONLY. SOME INFORMATION HAS BEEN SUPERCEDED SINCE ORIGINAL PUBLICATION. PLEASE REFER TO THE CURRENT PRODUCT SPECIFICATION BOOKLET FOR UP-TO-DATE STANDARD EQUIPMENT LIST & KIT WEIGHTS, PERFORMANCE, AND DIRECT OPERATING COST.

BELL 206B JETRANGER III

CAUTION PANEL

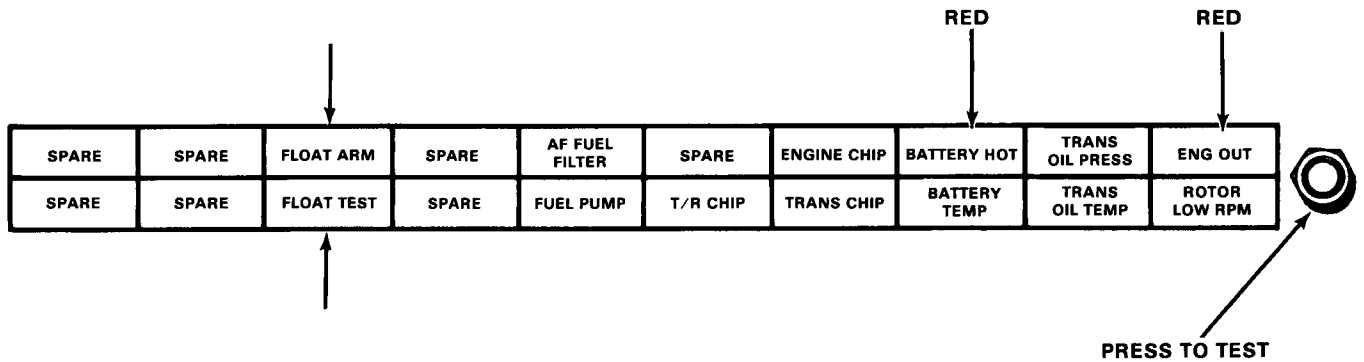

FLOAT
ARMING/INFLATION
ABOVE 60 MPH
PROHIBITED

MAXIMUM ALLOWABLE AIRSPEED
FLOATS INFLATED - 80 MPH
(69 KNOTS) IAS

MAXIMUM AUTOROTATION
AIRSPEED, FLOATS INFLATED -
70 MPH (60 KNOTS) IAS

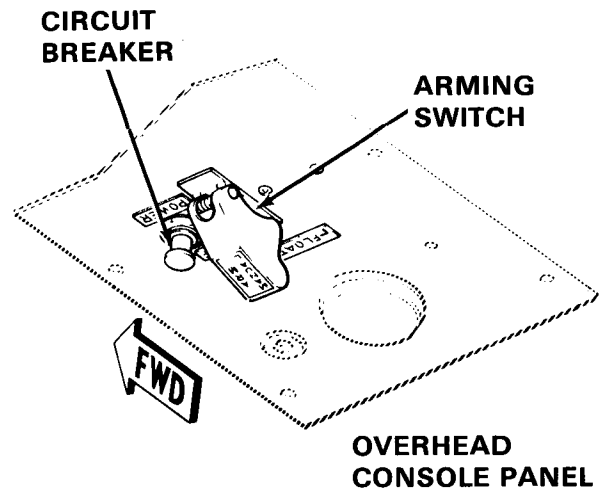
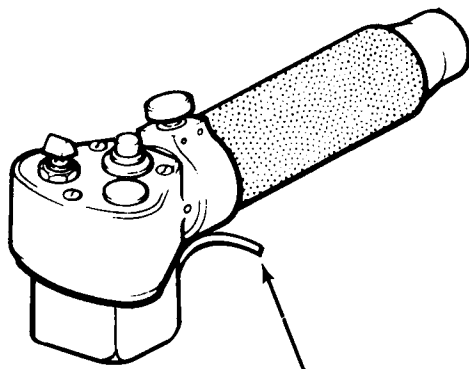
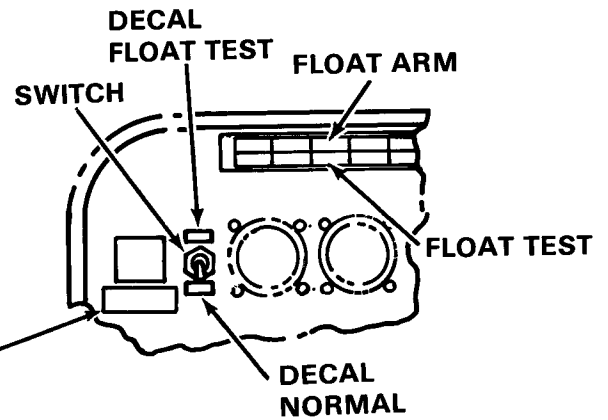



THIS IS AN UNCONTROLLED DOCUMENT. THE DATA IS PRESENTED FOR GENERAL INFORMATION ONLY. SOME INFORMATION HAS BEEN SUPERCEDED SINCE ORIGINAL PUBLICATION. PLEASE REFER TO THE CURRENT PRODUCT SPECIFICATION BOOKLET FOR UP-TO-DATE STANDARD EQUIPMENT LIST & KIT WEIGHTS, PERFORMANCE, AND DIRECT OPERATING COST.

BELL 206B
JETRANGER III



023733



THIS IS AN UNCONTROLLED DOCUMENT. THE DATA IS PRESENTED FOR GENERAL INFORMATION ONLY. SOME INFORMATION HAS BEEN SUPERCEDED SINCE ORIGINAL PUBLICATION. PLEASE REFER TO THE CURRENT PRODUCT SPECIFICATION BOOKLET FOR UP-TO-DATE STANDARD EQUIPMENT LIST & KIT WEIGHTS, PERFORMANCE, AND DIRECT OPERATING COST.

BELL 206B *JETRANGER III*

Dimensions in meters and (feet) measured at 1452 kilograms (3200 pounds) gross weight.

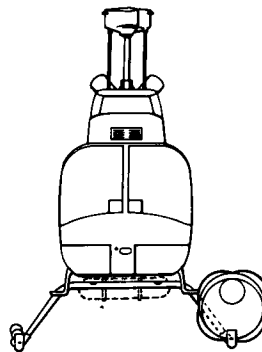
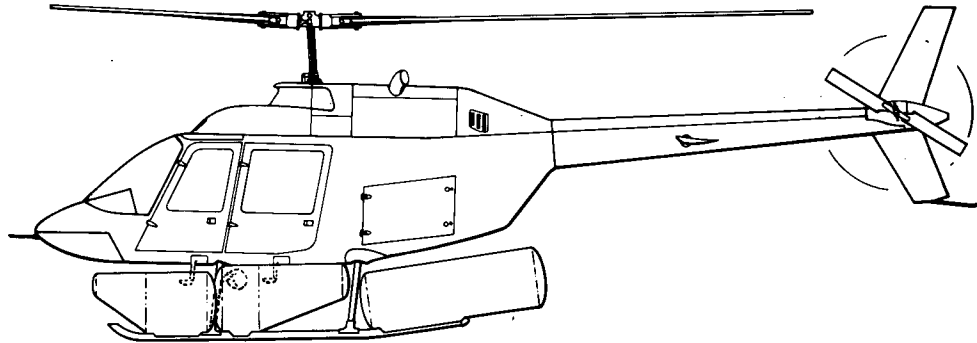



THIS IS AN UNCONTROLLED DOCUMENT. THE DATA IS PRESENTED FOR GENERAL INFORMATION ONLY. SOME INFORMATION HAS BEEN SUPERCEDED SINCE ORIGINAL PUBLICATION. PLEASE REFER TO THE CURRENT PRODUCT SPECIFICATION BOOKLET FOR UP-TO-DATE STANDARD EQUIPMENT LIST & KIT WEIGHTS, PERFORMANCE, AND DIRECT OPERATING COST.

BELL 206B
JETRANGER III



DUAL CONTROLS

BELL KIT NO. 206-706-127-101

The purpose of the Dual Controls Kit is to provide flight controls for the left front position - a second pilot's station - either for operations requiring a two-man flight crew or for pilot training.

Similar to the main controls in appearance, they provide all the major functions as well as identical control "feel". The collective stick includes a fully functioning twist-grip throttle controls.

Provisions are incorporated in all Jet-Ranger airframes to accept the dual controls kit with no change in the five-place seating arrangement.

When the dual controls are to be removed for an extended period, special protective covers are available. They are listed in the custom and vendor equipment section.

The kit consists of cyclic and collective sticks and anti-torque pedals for the left front seat.

The quick-disconnect feature enables the rapid removal of the cyclic and collective sticks without the use of tools. The ease of the removal facilitates quick conversion to the ambulance configuration.

An electric plug, included in the kit, is inserted in the place of the cyclic stick electric cable. It completes the electric circuits that are interrupted when the cyclic stick is removed.

The weight increase with the dual controls installed is 4.0 kilograms (8.9 pounds).

Installation and Maintenance Instructions are contained in Bell Service Instruction 206-67.



025252



THIS IS AN UNCONTROLLED DOCUMENT. THE DATA IS PRESENTED FOR GENERAL INFORMATION ONLY. SOME INFORMATION HAS BEEN SUPERCEDED SINCE ORIGINAL PUBLICATION. PLEASE REFER TO THE CURRENT PRODUCT SPECIFICATION BOOKLET FOR UP-TO-DATE STANDARD EQUIPMENT LIST & KIT WEIGHTS, PERFORMANCE, AND DIRECT OPERATING COST.

BELL 206B JETRANGER III

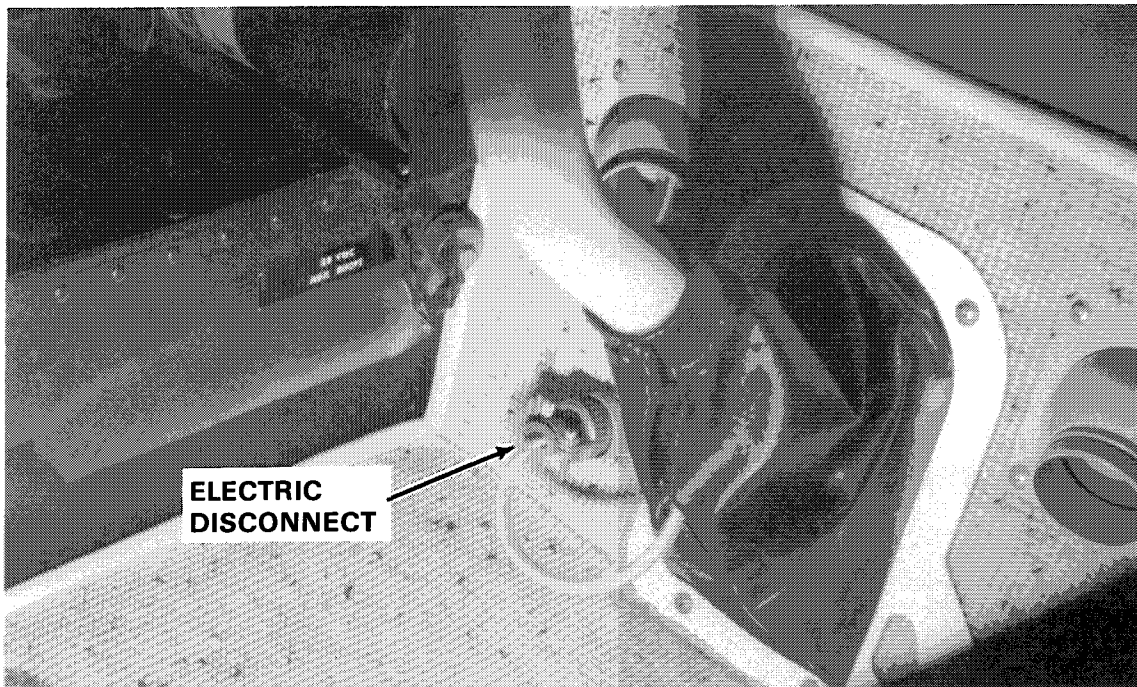
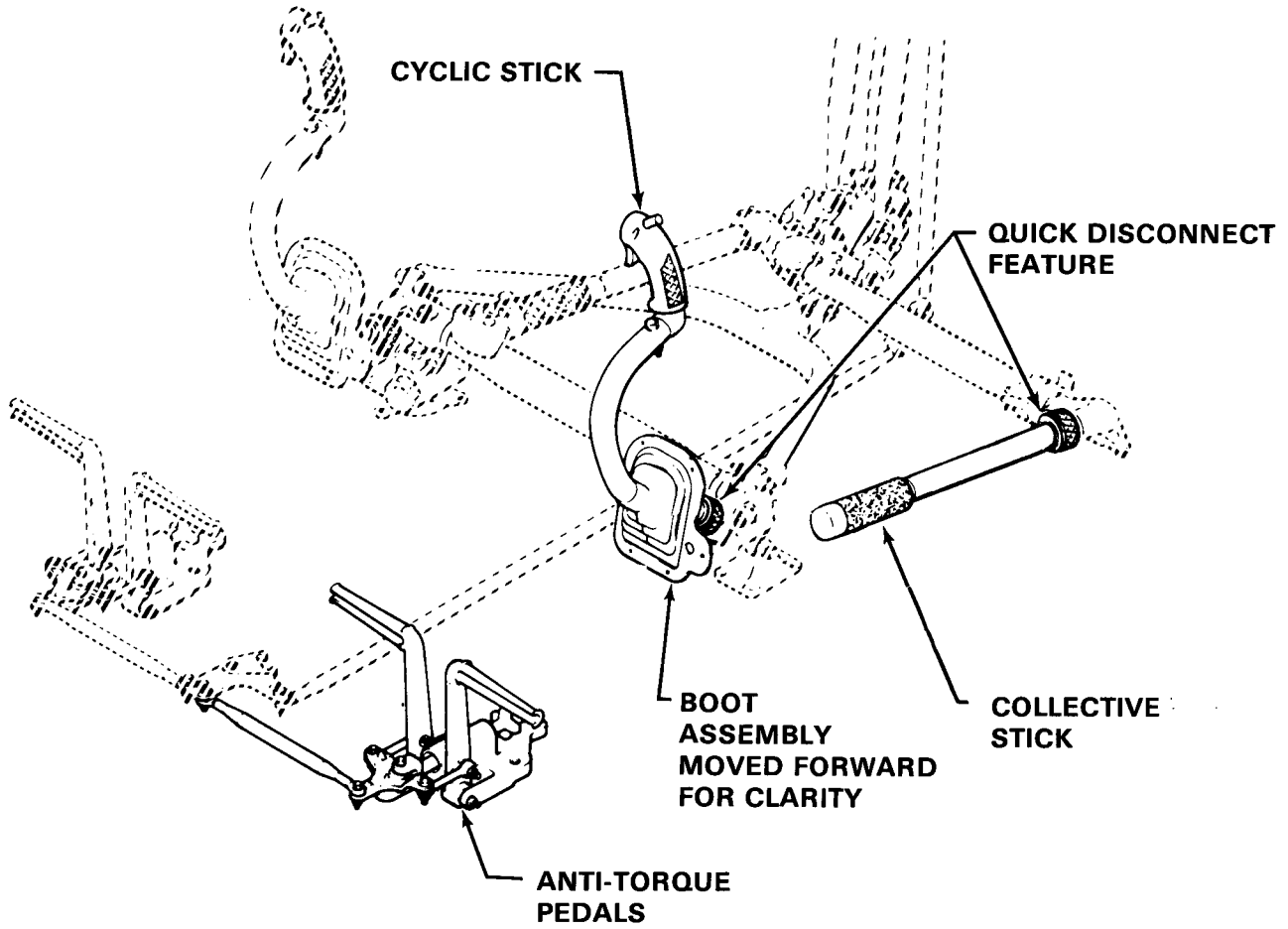

02272



ROTOR BRAKE

BELL KIT NO. 206-705-034-103

The purpose of the Rotor Brake Kit is to provide rapid deceleration and positive stopping of the main and tail rotors after engine shutdown. It is particularly useful in preventing the windmilling action of the main rotor in high and gusty wind conditions.

Pressure is applied to the system manually by pulling down on the operating handle when the rotor rpm is between 38 and 30 percent. This should bring the dynamic components to a complete stop in forty seconds.

When the rotor is stopped, and positioned for parking, the handle can be pulled fully down into the parking brake position. This locks and holds the dynamic components. Spring-loaded catches hold the handle in either the full off position or the parking position.

The kit consists of a completely self-contained hydraulic system which includes a brake disk, dual brake assembly, master cylinder and operating handle, hose and tube assemblies and required fittings and hardware to complete the installation.

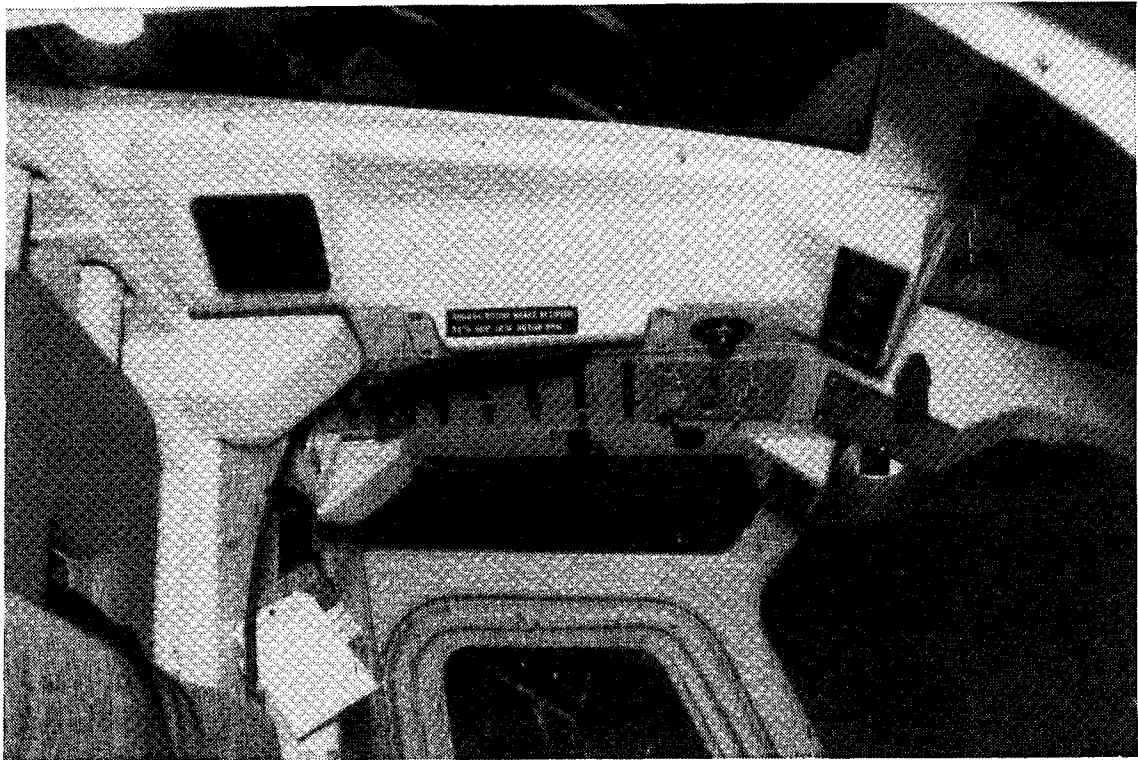



The brake disk is bolted to the aft coupling on the engine-to-transmission main driveshaft and rotates with the shaft. The stationary face of the freewheeling housing assembly is modified to accept the dual brake assembly, which is then bolted to it. The dual brake assembly encloses two pairs of pucks in caliper configuration, horizontally located on either side of the disk. The two pucks in each of the two calipers are also opposite each other so that when hydraulic pressure is applied, they provide a smooth, squeezing action on the disk.

The operating handle and the master cylinder unit is mounted on the roof of the crew compartment, immediately to the right of the overhead console. It is convenient to either pilot or copilot.

The weight increase with the Rotor Brake installed is 6 kilograms (13.2 pounds).

Flight Procedures are contained in the Flight Manual Supplement.

Installation and Maintenance Instructions are contained in Bell Service Instruction 206-105.





THIS IS AN UNCONTROLLED DOCUMENT. THE DATA IS PRESENTED FOR GENERAL INFORMATION ONLY. SOME INFORMATION HAS BEEN SUPERCEDED SINCE ORIGINAL PUBLICATION. PLEASE REFER TO THE CURRENT PRODUCT SPECIFICATION BOOKLET FOR UP-TO-DATE STANDARD EQUIPMENT LIST & KIT WEIGHTS, PERFORMANCE, AND DIRECT OPERATING COST.

BELL 206B JETRANGER III

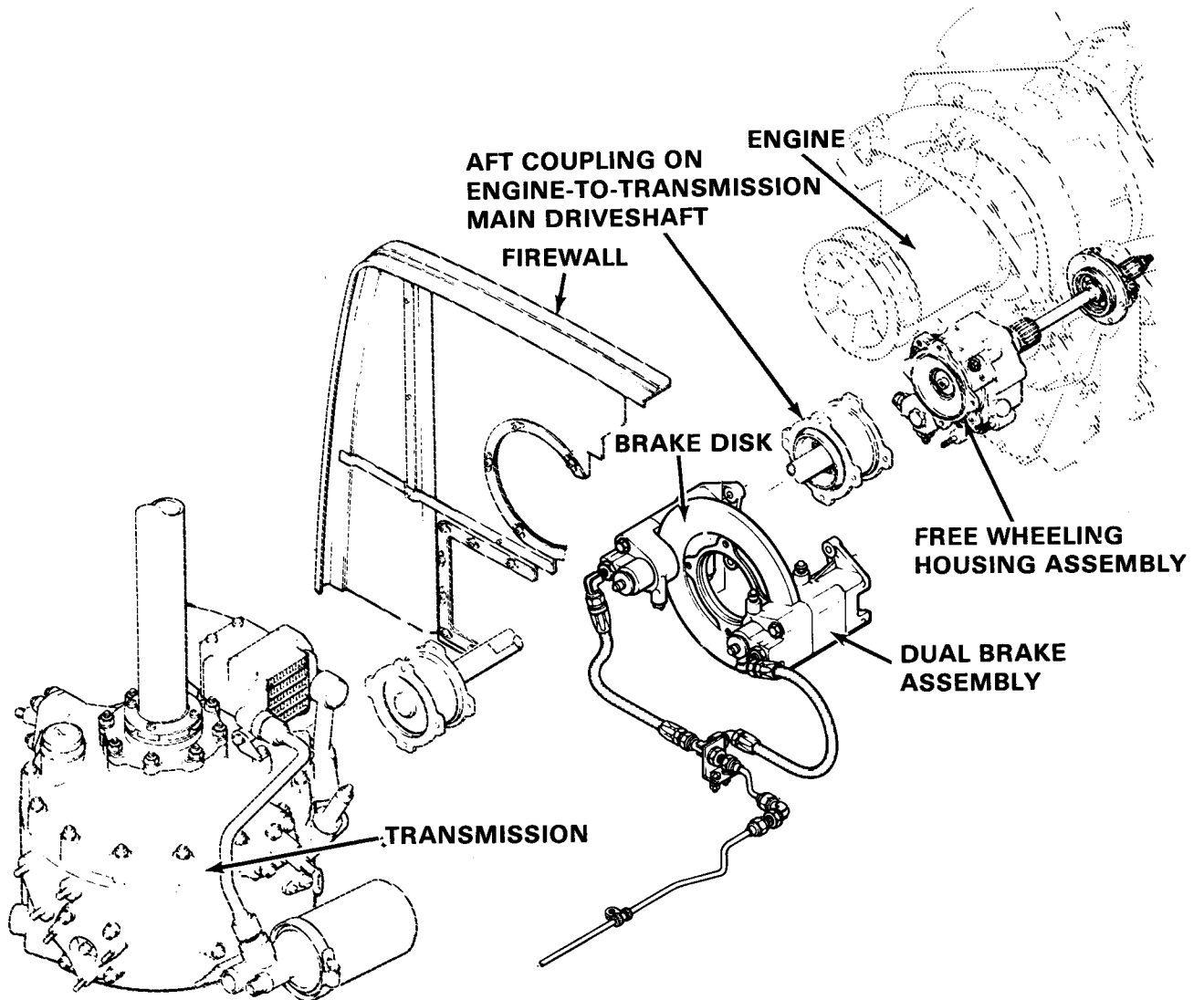



THIS IS AN UNCONTROLLED DOCUMENT. THE DATA IS PRESENTED FOR GENERAL INFORMATION ONLY. SOME INFORMATION HAS BEEN SUPERCEDED SINCE ORIGINAL PUBLICATION. PLEASE REFER TO THE CURRENT PRODUCT SPECIFICATION BOOKLET FOR UP-TO-DATE STANDARD EQUIPMENT LIST & KIT WEIGHTS, PERFORMANCE, AND DIRECT OPERATING COST.

BELL 206B
JETRANGER III

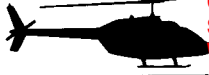

PARTICLE SEPARATOR

BELL KIT NO. 206-706-200-103

The purpose of the Particle Separator kit is to protect the engine against the ingestion of sand, dust and other foreign debris, with a minimum power loss. The separator, when installed, will permit flight in less than desirable environmental operating conditions.

When installed in conjunction with the Deflector Kit (Bell Kit No. 206-706-136-001), operations are permitted in falling or blowing snow. Limits are defined in the flight manual.

The kit consists of the separator, bleed air tubing and hoses, compressor wash fittings, and other hardware required to complete the installation.

The separator is installed just forward of the engine and all engine inlet air must pass through it.

Each of the 281 filter elements or tube assemblies in the separator, through which all inlet air must pass, consists of a vortex generator bonded into an inlet tube and a second, smaller tube which forms a scavenge chamber. The vortex generators are 1.7 centimeters (5/8 inch) in diameter.

Foreign particles that enter the filter elements are spun in the vortex generator and hurled centrifugally into the scavenge chamber. This debris is then ejected overboard by the vacuum-cleaner effect created by engine bleed air as it is discharged through venturis

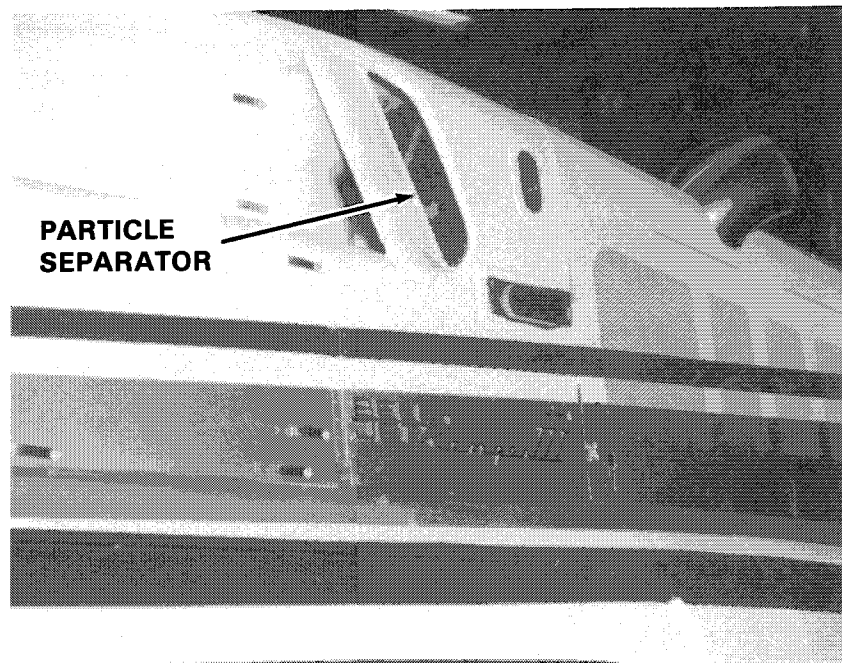

02272



in the ejector tubes. The scavenge flow which carries the debris with it, accounts for approximately 8% of the inlet air flow.

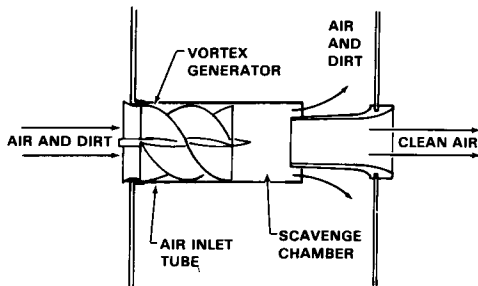

FILTER ELEMENT

The particle separator has a tested efficiency of 85% by weight for AC coarse particles (27 micron nominal). Due to its inertial (centrifugal) action, the separator is more efficient for particles larger than 27 microns, and less efficient for particles smaller than 27 microns.

Foreign debris such as hay, leaves, etc., which are too large to enter the filter elements are stopped at the face of the separator. However, the numerous filter elements are so placed that there is sufficient air flow, bypassing the blockage, even for prolonged periods of flight in such conditions. The possibility of engine flameout or compressor damage caused by large pieces of dislodged ice or snow has also been eliminated.

The compressor wash system requires relocation of some of the fittings if it is desirable to retain it with the separator installed.

The weight increase with Particle Separator installed is 3 kilograms (6.5 pounds).

Flight procedures are contained in the Flight Manual Supplement.

Installation imposes no aerodynamic restrictions and has no effect on the maximum gross weight. Because of the increased pressure drop in the inlet and the constant use of bleed air to purge the system, there is a slight reduction of power available when the separator is installed. This amounts to a 3% torque loss and is covered in the flight manual supplement, for each configuration. When operations do not require the added protection, the separator can be removed and the engine air intake screens replaced. This regains the full engine performance.

The particle separator must be installed before the snow baffles kit 206-706-136-001 can be used. Similarly, if the separator is removed, then the snow baffles must be removed.

Installation and Maintenance Instructions are contained in Bell Service Instruction No. 206-83.



**DEFLECTOR KIT
(SNOW BAFFLES)
(ENGINE AIR INDUCTION SYSTEM)
(REQUIRES INSTALLATION OF THE PARTICLE SEPARATOR)
BELL KIT NO. 206-706-136-001**

The purpose of the Snow Baffles kit is to permit extended flight in falling or blowing snow by reducing the quantity of snow entering the engine air induction system.

The Snow Baffles prevent direct flow of air into the inlets. This reduces the quantity of heavy snow entering the engine air intake by forcing the air into a reverse flow pattern.

The Particle Separator Engine Air Induction System (Bell Kit No. 206-706-200-103) must be installed concurrently with the Deflector Kit in order to operate in falling or blowing snow.

The kit consists of a matching pair of baffle assemblies that mount, one on each side of the transmission cowling, just forward of the engine air inlets. The attachment fittings are already provided as standard equipment.

The weight increase with Snow Baffles installed is 1.4 kilograms (3 pounds).

Flight procedures are contained in the Flight Manual Supplement.

The 206B, with the particle separator and the Snow Baffle kit installed, has FAA approval for flight in falling or blowing snow, when visibility is in excess of 0.8 kilometers ($\frac{1}{2}$ mile). However, hovering in blowing snow conditions with the deflectors on is limited to 20 minutes.

Once installed, the baffles are easily removed or replaced, and are normally removed when the risk of having to operate in falling snow is over. Whenever the particle separator is removed, the baffles must be removed.

The Deflector kit shall be removed when the ambient temperature is 80° Fahrenheit (26.7° Centigrade).

Installation and Maintenance Instructions are contained in Bell Service Instruction 206-103.

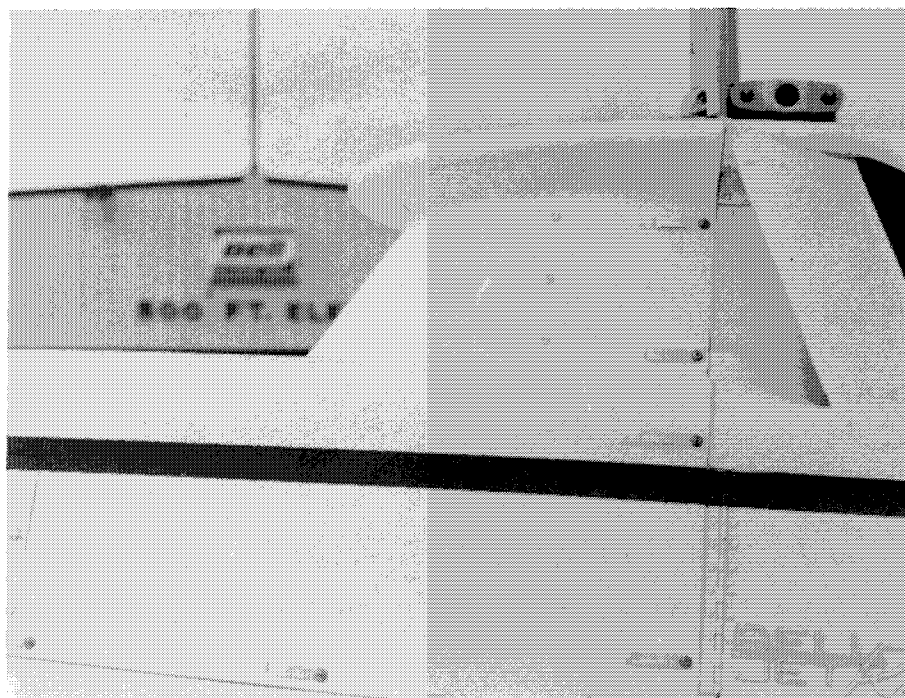



THIS IS AN UNCONTROLLED DOCUMENT. THE DATA IS PRESENTED FOR GENERAL INFORMATION ONLY. SOME INFORMATION HAS BEEN SUPERCEDED SINCE ORIGINAL PUBLICATION. PLEASE REFER TO THE CURRENT PRODUCT SPECIFICATION BOOKLET FOR UP-TO-DATE STANDARD EQUIPMENT LIST & KIT WEIGHTS, PERFORMANCE, AND DIRECT OPERATING COST.

BELL 206B
JETRANGER III

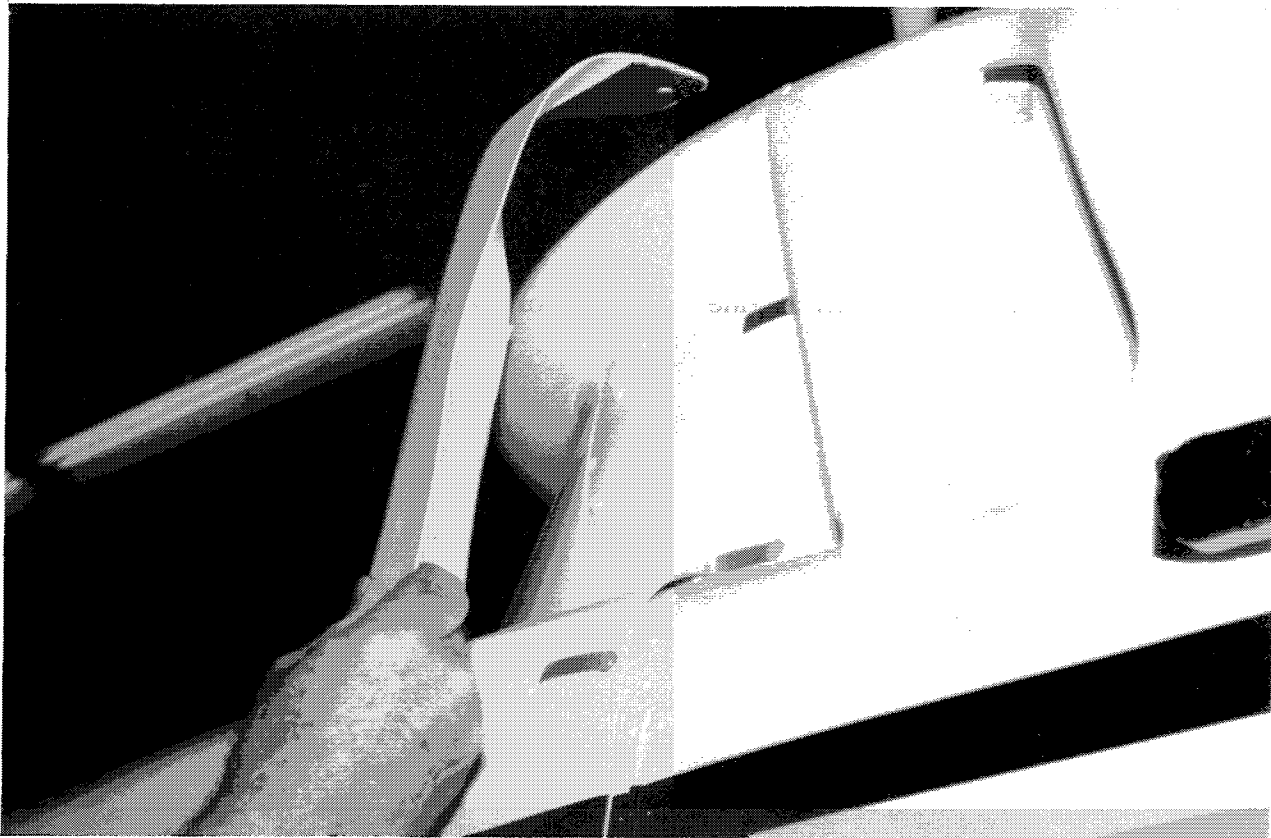

02272

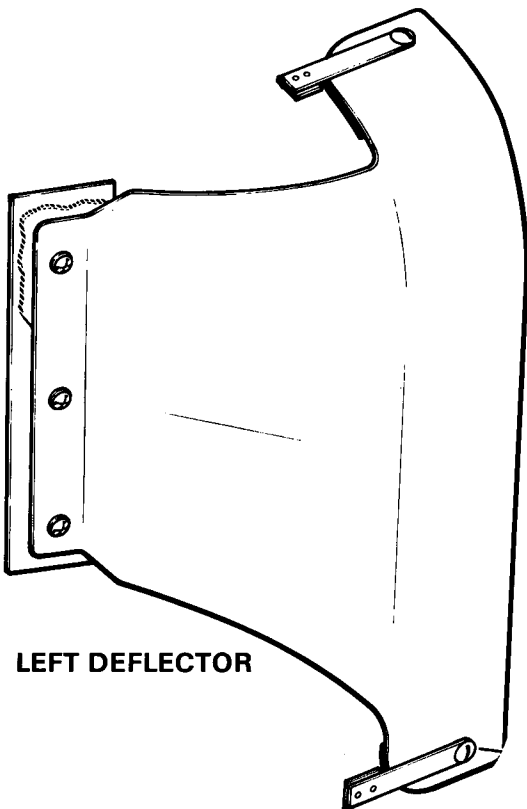

LEFT DEFLECTOR

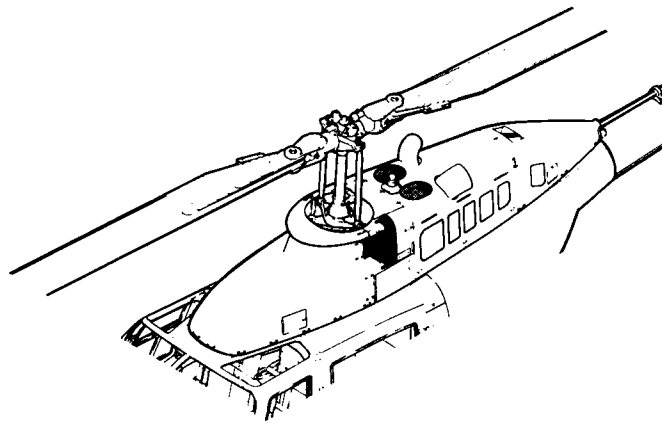



AUTOMATIC ENGINE RE-IGNITION

BELL KIT NO. 206-706-038-003

The purpose of the Automatic Engine Re-ignition kit is to provide automatic re-ignition in the event of an engine flameout.

When the system is armed, it will be activated automatically by the decay of engine compressor discharge pressure.

The kit consists of a control assembly, a switch and a caution light and the necessary relays, wiring, tubing and hardware to complete the installation.

The control assembly senses the decay of engine bleed air pressure. The control switch has three-positions: OFF RESET in the lower position, armed ENGINE RELIGHT in the center, and TEST in the upper, spring-loaded, position. The ENGINE RELIGHT caution light activates when re-ignition occurs.

The relays (remote switches for the heavy-duty igniter circuit) are mounted in the baggage compartment roof.

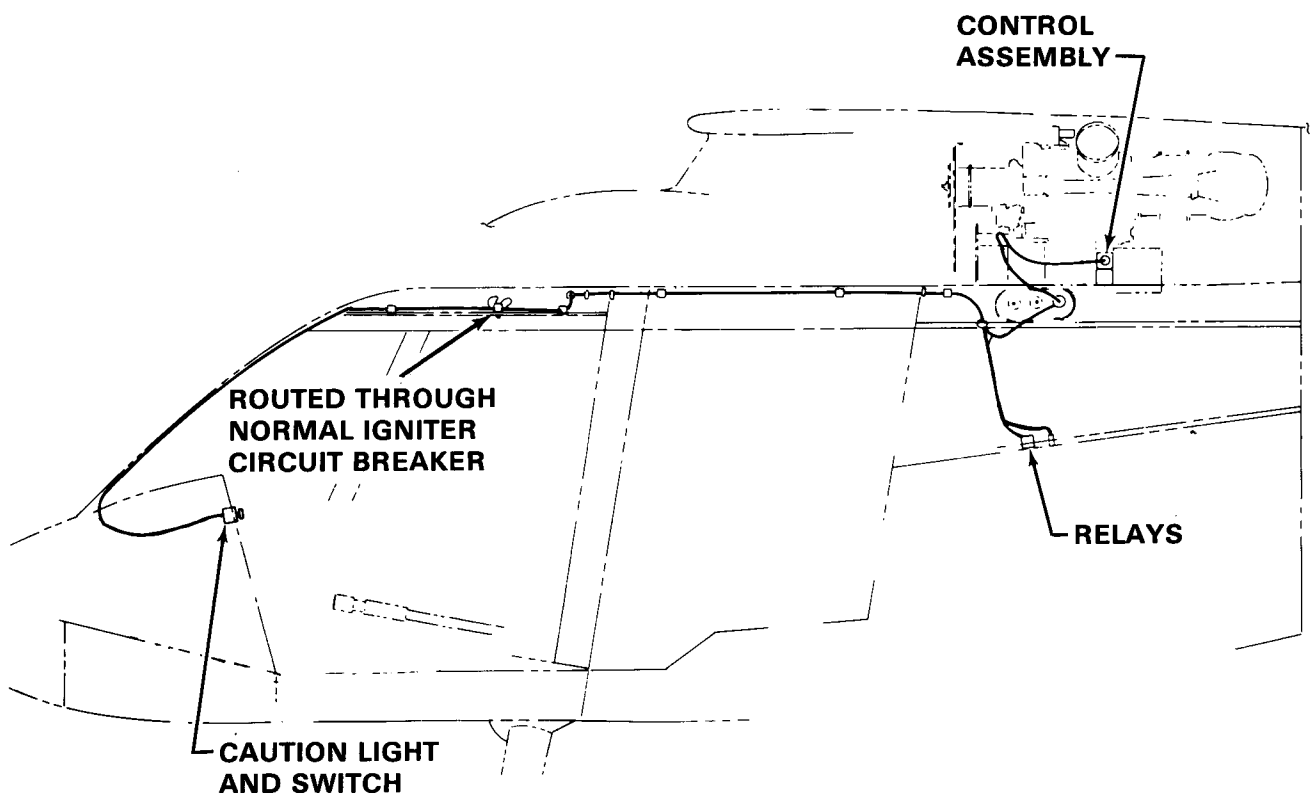



CAUTION PANEL

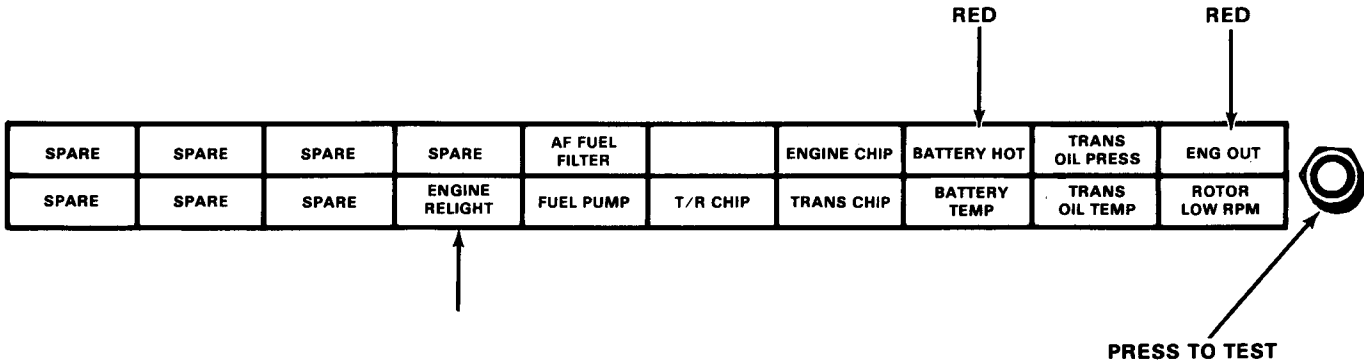

The weight increase with the Automatic Engine Re-ignition kit installed in 1.7 kilograms (3.7 pounds).

Flight procedures and the testing sequence are contained in the Flight Manual Supplement.

When the engine is operating the pilot normally arms the automatic system. Should a flameout occur, it would cause an instant pressure differential which would activate the control unit. (A built-in delay prevents high torsional stresses in the main and tail rotor drive system components.) The engine igniter plug then fires to re-ignite the engine and the caution light illuminates. Should a second flameout occur during the re-ignition period, the control will interrupt the supply of power to the engine ignition exciter,

repeat the preset delay period, and then demand ignition once again. If the second re-ignition attempt fails, the control will not continue to recycle. The pilot should resort to manual air starting procedures which are always available.

After engine restart by the automatic re-ignition system, the system is automatically turned off and reset for any subsequent flameout. No action is required of the pilot, however, he should reset the light by momentarily switching to OFF RESET and returning to the armed ENGINE RELIGHT position.

This kit is not compatible with the optional Allison 250-C20R/4 engine.

Installation and Maintenance Instructions are contained in the Bell Service Instruction 206-92.

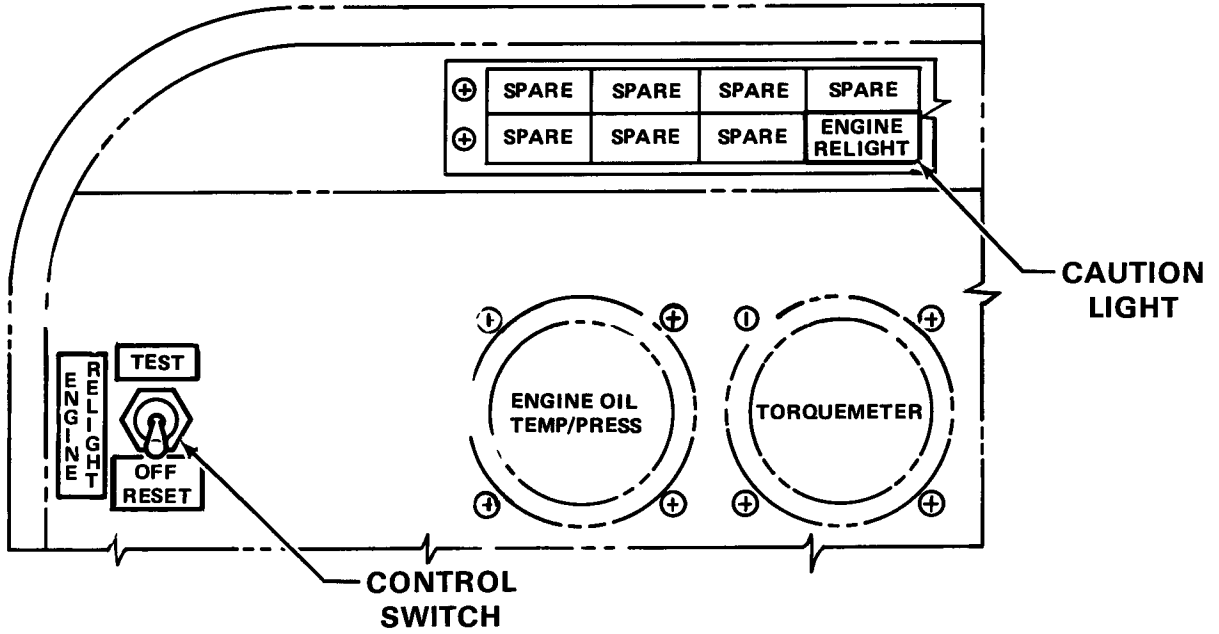



THIS IS AN UNCONTROLLED DOCUMENT. THE DATA IS PRESENTED FOR GENERAL INFORMATION ONLY. SOME INFORMATION HAS BEEN SUPERCEDED SINCE ORIGINAL PUBLICATION. PLEASE REFER TO THE CURRENT PRODUCT SPECIFICATION BOOKLET FOR UP-TO-DATE STANDARD EQUIPMENT LIST & KIT WEIGHTS, PERFORMANCE, AND DIRECT OPERATING COST.

BELL 206B
JETRANGER III



FLIGHT INSTRUMENT GROUP

BELL KIT NO. 206-706-323-019

The purpose of the Flight Instrument Group kit is to augment the basic panel with the most popular grouping of additional flight instruments - a directional gyro, attitude indicator, rate of climb and a turn and slip indicator - and to provide a heated pitot tube.

The kit reduces the pilot workload by providing better, easier to interpret displays, and permits more accurate flying techniques. This in turn extends the operational area.

It is invaluable for flight safety in low visibility, particularly at night when operating away from inhabited areas, and as conditions approach flight limits.

Although the selection of instruments and the layout offered in the kit is only

one of any number of possible arrangements, it has been designed to properly complement the basic panel and to prepare for a further addition of navigation and other aids. It is the first step to a well-coordinated full panel.

The kit consists of the four instruments and all the tubing, wiring, circuit breakers and hardware necessary to install the instruments and provide pitot tube heat.

The electrical instruments operate on direct current which is already available in the helicopter.

The integral blue-white lighting matches the standard basic panel lighting.



025265

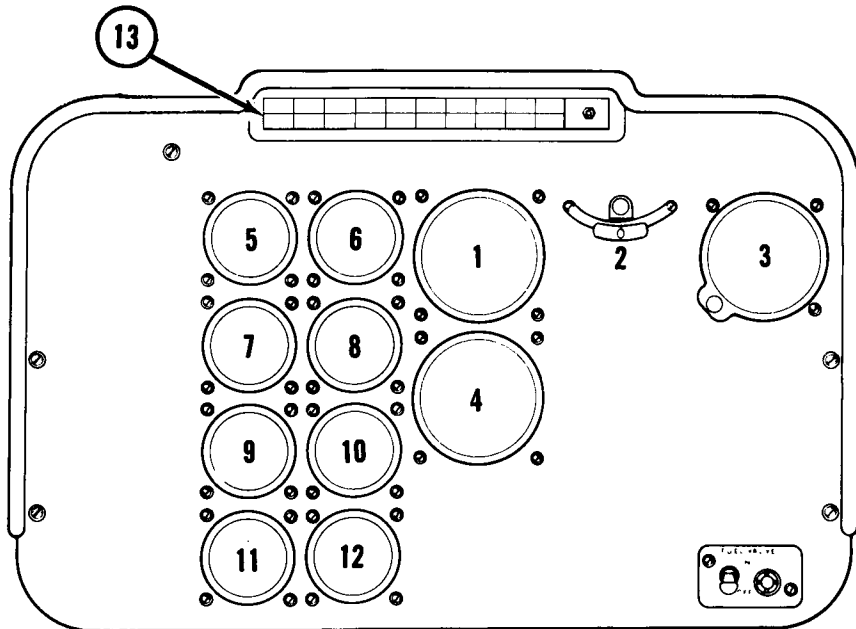

STANDARD INSTRUMENT PANEL



025265

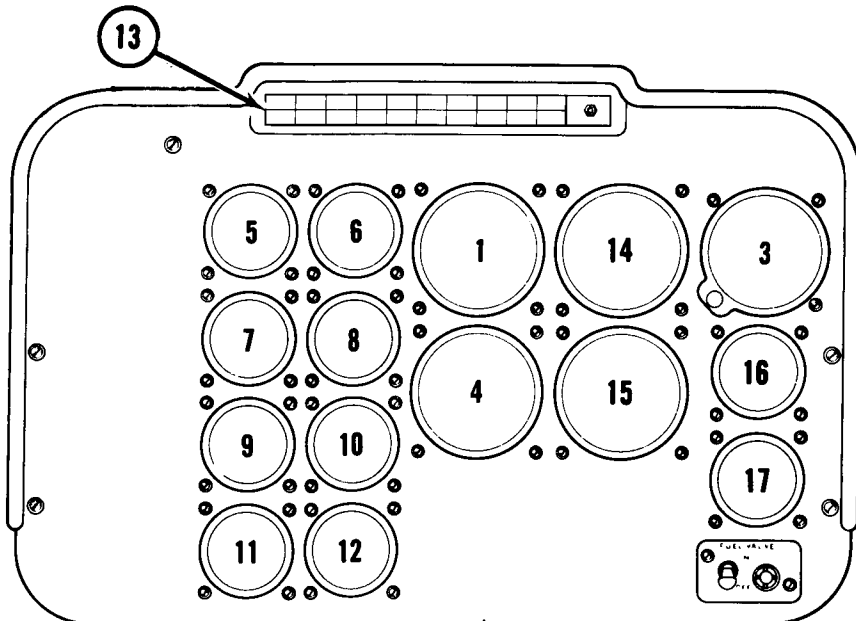

WITH FLIGHT INSTRUMENT KIT INSTALLED



025266

- | | | |
|---|--|---------------------------------------|
| 1. Airspeed Indicator (with electrically heated pitot tube) | 6. Torquemeter | 11. Fuel Pressure/Loadmeter Indicator |
| 2. Inclinometer | 7. Transmission Oil Temperature/Pressure Indicator | 12. Clock |
| 3. Altimeter | 8. Turbine Outlet Temperature Indicator | 13. Caution Panel |
| 4. Dual Tachometer | 9. Fuel Quantity Indicator | 14. Artificial Horizon |
| 5. Engine Oil Temperature/Pressure Indicator | 10. Gas Producer Indicator | 15. Directional Gyro |
| | | 16. Rate of Climb |
| | | 17. Turn and Slip |



THIS IS AN UNCONTROLLED DOCUMENT. THE DATA IS PRESENTED FOR GENERAL INFORMATION ONLY. SOME INFORMATION HAS BEEN SUPERCEDED SINCE ORIGINAL PUBLICATION. PLEASE REFER TO THE CURRENT PRODUCT SPECIFICATION BOOKLET FOR UP-TO-DATE STANDARD EQUIPMENT LIST & KIT WEIGHTS, PERFORMANCE, AND DIRECT OPERATING COST.

BELL 206B JETRANGER III

The weight increase with the Flight Instruments Group kit installed is 4.4 kilograms (9.6 pounds).

Installation and Maintenance Instructions are contained in Bell Service Instruction 206-53.

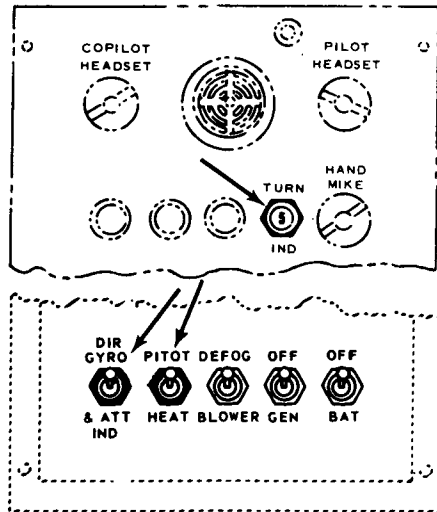

**OVERHEAD
PANEL**

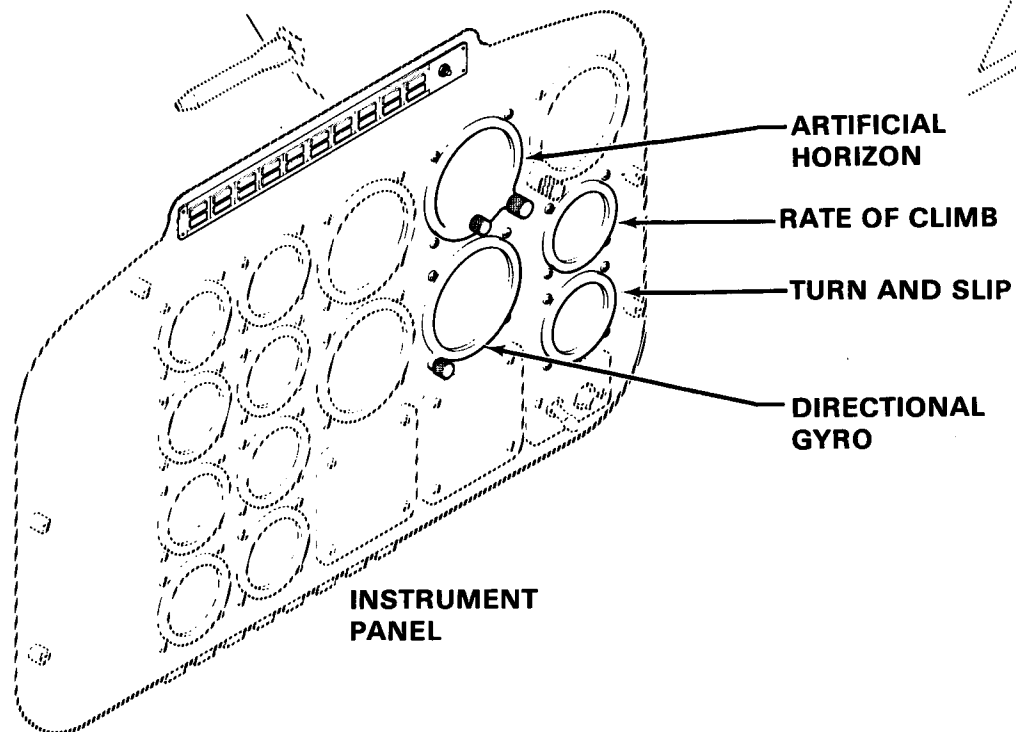
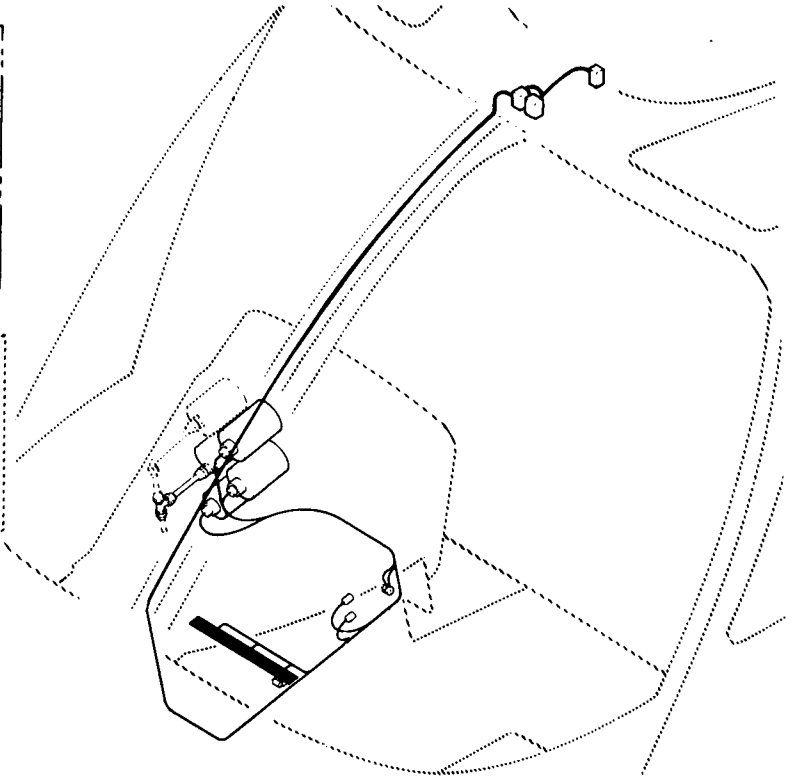

**INSTRUMENT
PANEL**



THIS IS AN UNCONTROLLED DOCUMENT. THE DATA IS PRESENTED FOR GENERAL INFORMATION ONLY. SOME INFORMATION HAS BEEN SUPERCEDED SINCE ORIGINAL PUBLICATION. PLEASE REFER TO THE CURRENT PRODUCT SPECIFICATION BOOKLET FOR UP-TO-DATE STANDARD EQUIPMENT LIST & KIT WEIGHTS, PERFORMANCE, AND DIRECT OPERATING COST.

BELL 206B
JETRANGER III



**VHF COMMUNICATION/NAVIGATION TRANSCEIVER
KING KX 155**

BELL KIT NO. 206-705-008-133
PROVISIONS KIT
BELL KIT NO. 206-705-008-103
TRANSCEIVER KIT

The purpose of the VHF Communication/Navigation Transceiver kits is to provide:

An aviation radio - King KX 155

- VHF two-way voice communications, 720 channels in the 118 to 135.975 megahertz range
- Intercommunication between pilot and copilot

- 200 Navigation channels in the 108 to 117.95 megahertz range
- Channeling for distance measuring equipment

Cabin speakers

A management system to manage the flow of radio communications to and from the helicopter when there is more than one radio in the system.

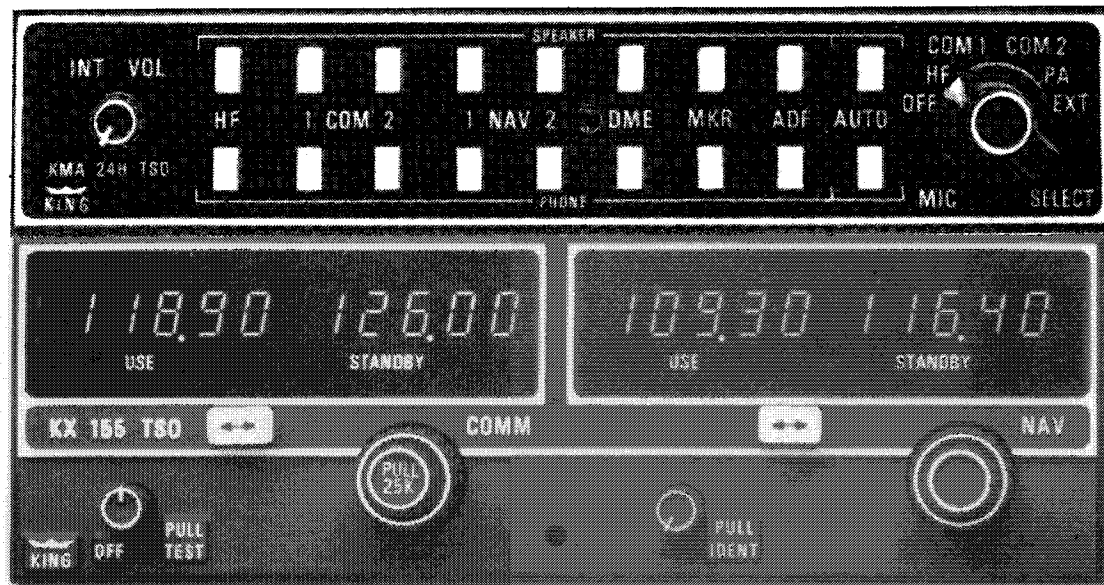



The King KMA 24H Audio Panel enables the audio management of up to three transceivers and five receivers.

The pilot can select which transmitter is active and which combination receivers will be directed to headsets, and to speakers.

A second KX 155 Transceiver can be quickly and easily added to the system. Although it will cover the same frequency range, both can be operated simultaneously on different channels.

When a second indicator is installed, the two transceivers provide two sources of navigational information.

The two separate kits - the provisions kit and the transceiver kit - allow the customer complete flexibility.

The Provisions Kit, No. 206-705-008-133 consists of a King KMA 24H audio panel, two Quam-Nichols speakers in the forward cabin, and the antenna for the KX 155. Hardware includes all the cables, mounting brackets, jacks and circuit breakers to complete the installation for either single or dual flight controls.

The transmit and ICS switches on the cyclic stick grip are connected. If dual controls are installed, the transmit and ICS switches on the copilot's cyclic grip are connected and the copilot's inter-communication foot switch is installed.

The audio panel is mounted above the transceiver, on the radio pedestal. It is back-lit with blue/white lighting.

A rotary switch allows the pilot to transmit on the selected communication transceiver (HF, COM 1 or COM 2), public address system or external speakers.

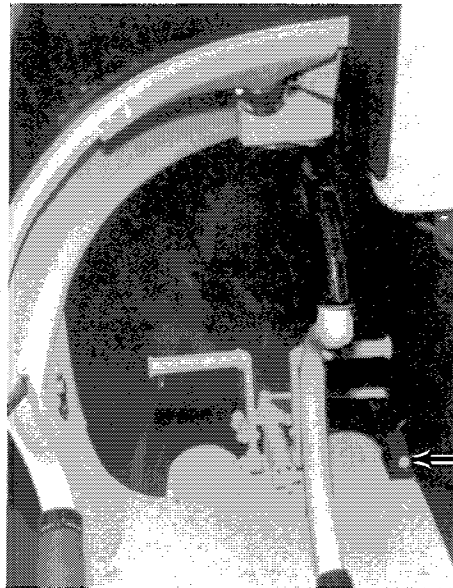

FOOT SWITCH

Foot Switch

The integral intercom with its own volume control can coordinate up to five microphone inputs and has adequate power to handle up to six headphones connected in parallel.

"Pilot priority" has been incorporated into making the mike switching. If both the pilot's and copilot's mike are keyed simultaneously, the pilot's mike is automatically given transmit priority. This authority can be designated, by internal adjustment, to either the pilot or copilot position to accommodate flying training needs.

The AUTO switch automatically links the speaker or headphones to the selected transmitter. When AUTO is being used, HF, COM 1 and COM 2 can be left in the OFF position.

The Transceiver Kit, No. 206-705-008-103, consists of the King KX 155 transceiver, two David Clark headsets each with an adequate length of coiled cable



THIS IS AN UNCONTROLLED DOCUMENT. THE DATA IS PRESENTED FOR GENERAL INFORMATION ONLY. SOME INFORMATION HAS BEEN SUPERCEDED SINCE ORIGINAL PUBLICATION. PLEASE REFER TO THE CURRENT PRODUCT SPECIFICATION BOOKLET FOR UP-TO-DATE STANDARD EQUIPMENT LIST & KIT WEIGHTS, PERFORMANCE, AND DIRECT OPERATING COST.

BELL 206B JETRANGER III

and built-in microphone, a vendor manual and warranty, and necessary hardware to complete the installation.

The Transceiver is part of the KING Silver Crown series. It is crystal controlled, solid state, and panel-mounted (159 X 52 X 258 mm; 6.25 X 2.05 X 10.2 inches). Internal lighting is blue/white.

The KX 155 has simultaneous digital display of one active and one standby frequency (either communication or navigation or both). A push button control switches to either one.

The weight increase with only the provisions kit installed is 5.9 kilograms (13 pounds). With the complete installation it is 9.1 kilograms (20 pounds). With a second KX 155 installed it is approximately 12.3 kilograms (27.2 pounds).

Installation and Maintenance Instructions. Bell or King service center installation is required in order to obtain the King full year warranty.

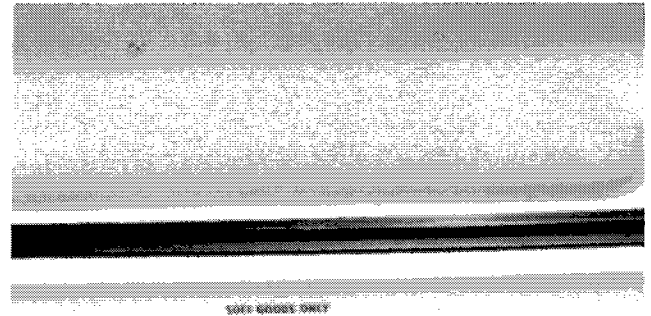

SOFT GOODS ONLY

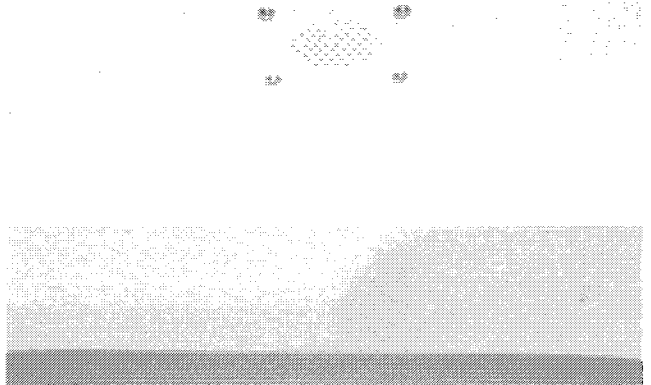

Cabin Speaker

023765

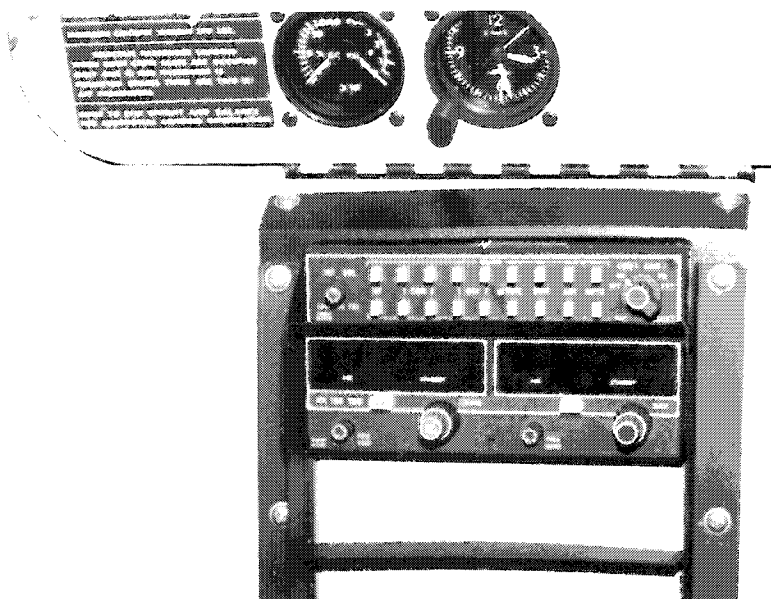

KMA 24H
AUDIO PANEL

KX 155
VHF TRANSCEIVER



THIS IS AN UNCONTROLLED DOCUMENT. THE DATA IS PRESENTED FOR GENERAL INFORMATION ONLY. SOME INFORMATION HAS BEEN SUPERCEDED SINCE ORIGINAL PUBLICATION. PLEASE REFER TO THE CURRENT PRODUCT SPECIFICATION BOOKLET FOR UP-TO-DATE STANDARD EQUIPMENT LIST & KIT WEIGHTS, PERFORMANCE, AND DIRECT OPERATING COST.

BELL 206B
JETRANGER III



02926

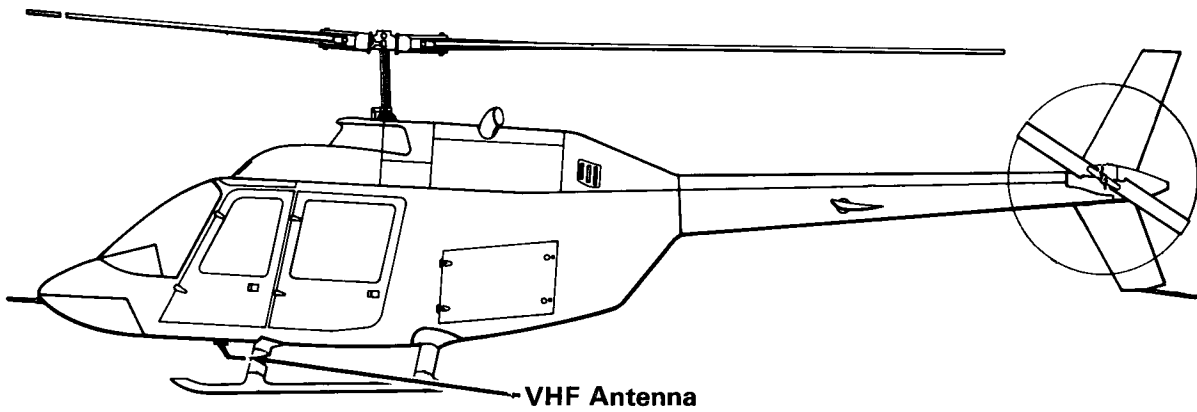



THIS IS AN UNCONTROLLED DOCUMENT. THE DATA IS PRESENTED FOR GENERAL INFORMATION ONLY. SOME INFORMATION HAS BEEN SUPERCEDED SINCE ORIGINAL PUBLICATION. PLEASE REFER TO THE CURRENT PRODUCT SPECIFICATION BOOKLET FOR UP-TO-DATE STANDARD EQUIPMENT LIST & KIT WEIGHTS, PERFORMANCE, AND DIRECT OPERATING COST.

BELL 206B
JETRANGER III



**COURSE DEVIATION INDICATOR
KING KI 208**

BELL KIT NO. 206-705-008-135

The purpose of the Course Deviation Indicator kit is to provide course deviation information from the selected VHF Omni Range (VOR) stations.

It works in conjunction with the KX 155 transceiver and the KMA 24H Audio Panel.

TO and FROM indication is graphically displayed and the large numbers are easy to read.

The kit consists of a King KI 208 indicator, a VOR antenna which mounts on top of the tail fin, and the required installation hardware.

The compass card of the KI 208 is turned, placing the desired course on the index at the top, using the omni bearing selector (OBS) knob.

The deviation needle swings right or left indicating deviation left or right of the selected course.

The heading of the helicopter has no effect on the TO or FROM indicators. They react only to the heading set on the indicator.

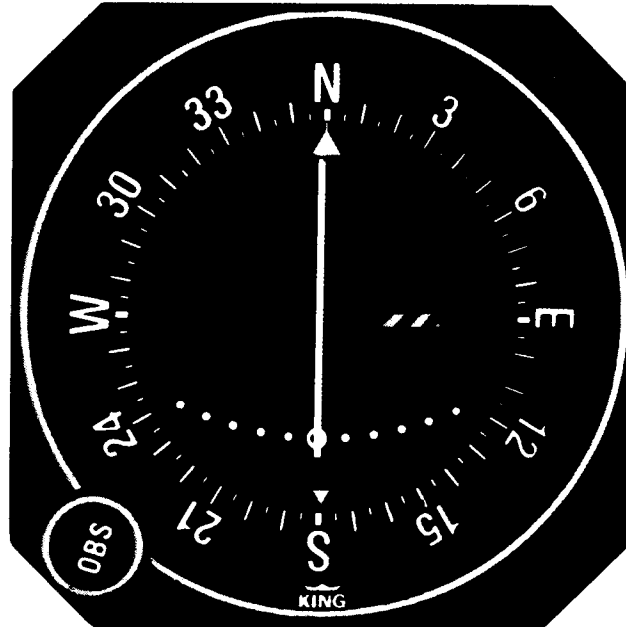

02926



THIS IS AN UNCONTROLLED DOCUMENT. THE DATA IS PRESENTED FOR GENERAL INFORMATION ONLY. SOME INFORMATION HAS BEEN SUPERCEDED SINCE ORIGINAL PUBLICATION. PLEASE REFER TO THE CURRENT PRODUCT SPECIFICATION BOOKLET FOR UP-TO-DATE STANDARD EQUIPMENT LIST & KIT WEIGHTS, PERFORMANCE, AND DIRECT OPERATING COST.

BELL 206B JETRANGER III

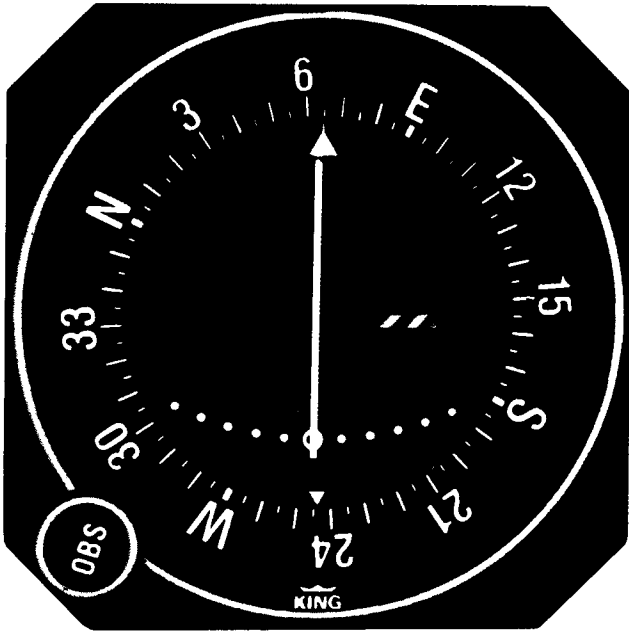

The OFF flag (barber pole) disappears when a valid signal is received.

The 76 mm (3 in) indicator has a built-in VOR/LOC converter. It has blue/white lighting and a prominent warning flag when inoperative.

The weight increase with the Course Deviation Indicator kit installed is 0.5 kilograms (1 pound).

Installation and Maintenance Instructions. Bell or King Service Center installation is required to obtain King's full year warranty.

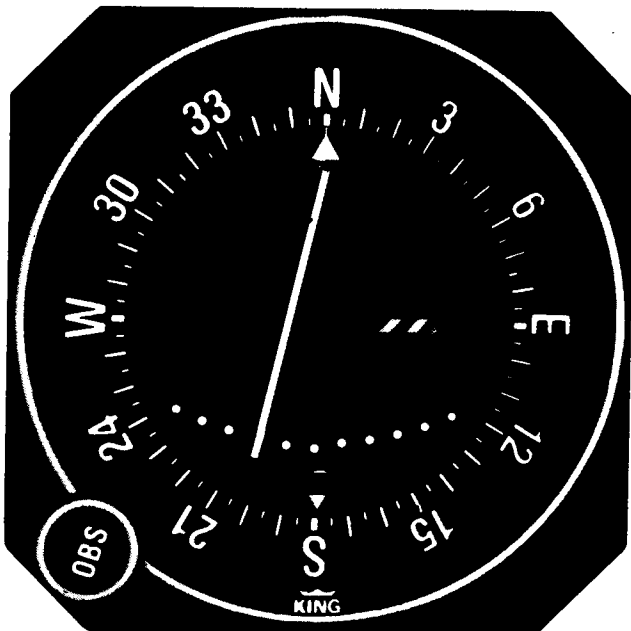

OFF

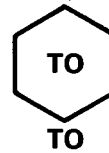

TO



FROM

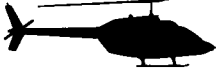

BELL 206B
JETRANGER III

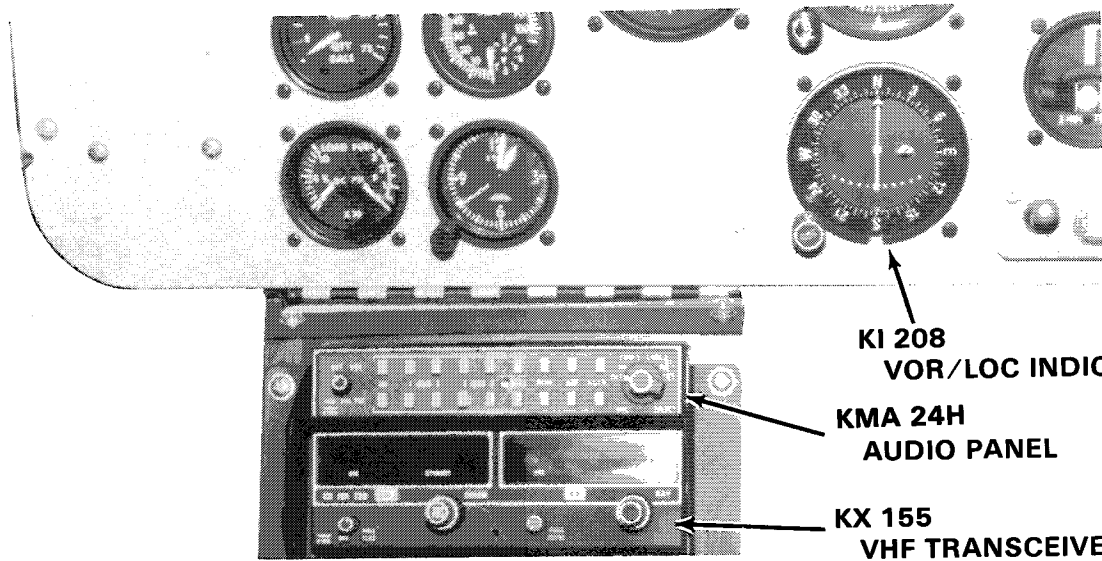

02279

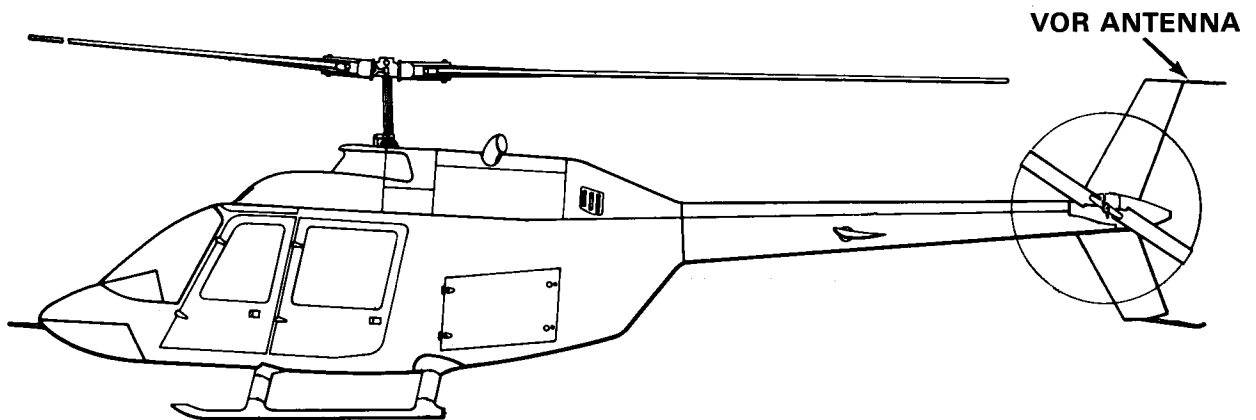



THIS IS AN UNCONTROLLED DOCUMENT. THE DATA IS PRESENTED FOR GENERAL INFORMATION ONLY. SOME INFORMATION HAS BEEN SUPERCEDED SINCE ORIGINAL PUBLICATION. PLEASE REFER TO THE CURRENT PRODUCT SPECIFICATION BOOKLET FOR UP-TO-DATE STANDARD EQUIPMENT LIST & KIT WEIGHTS, PERFORMANCE, AND DIRECT OPERATING COST.

BELL 206B
JETRANGER III



**AUTOMATIC DIRECTION FINDER
KING KR 87 AND KI 227**

BELL KIT NO. 206-705-008-131

The purpose of the Automatic Direction Finder kit is to provide the relative bearing to a selected transmitting station which is within the 200 to 1699 kilohertz range. The needle on the KI 227 indicator shows the direction of the radio transmitter relative to the aircraft's heading. The KR 87 displays the active ADF frequency on the left. A digital time readout is on the right to show flight time (FLT) or Event Time (ET). The KI 227 has a manually ro-

tatable compass card. The receiver covers the commercial radio bands.

The KR 87 has pushbutton switching between the preselected "active" and the "standby" frequency. Both frequencies are stored in a non-volatile memory which retains the frequencies during power shutdowns.

An integral timer provides display of flight and elapsed time and can be

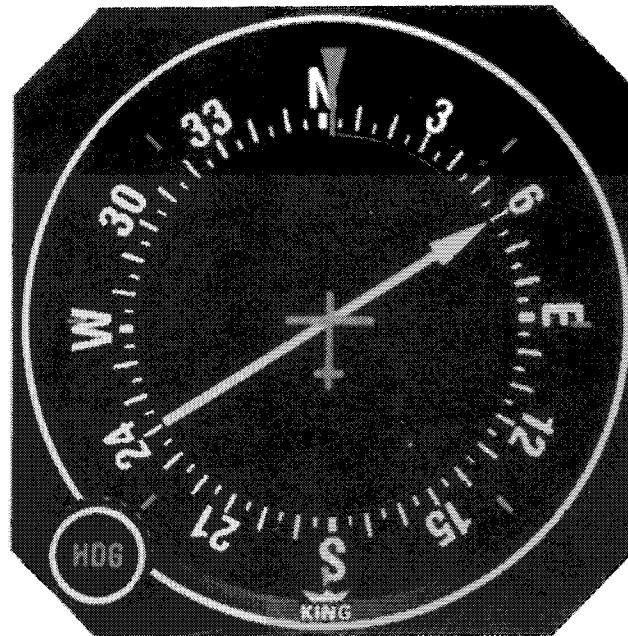

KI 227 ADF Indicator

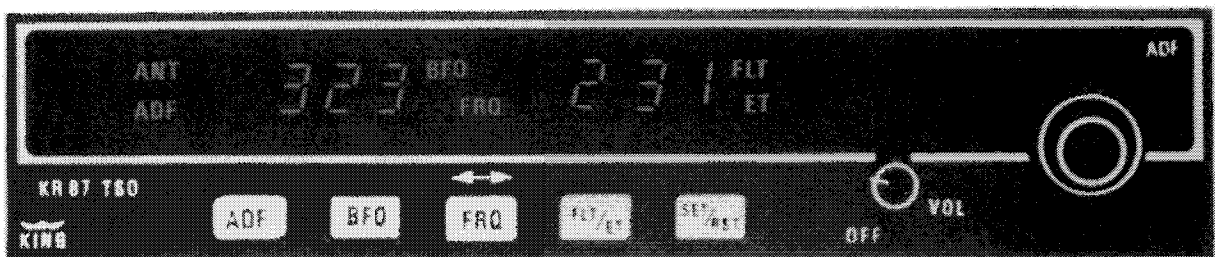

KR 87 ADF



programmed to count up or down for timed approaches, trip leg timing or fuel management. A visual alarm can be set.

The flight timer and elapsed timer can be operated and monitored independently.

The kit consists of the King KR 87 ADF receiver, the King KI 227 ADF Indicator, a loop/sense blade antenna, the wiring and hardware required to complete the installation, a vendor manual and the warranty.

The receiver is crystal controlled with digital tuning for positive, easy operation. It is solid-state, self contained, pedestal mounted (159 X 33 X 257 mm, 6.25 X 1.35 X 10.13 inches). Once the volume control is set, audio reception volume is held relatively constant over wide variations of signal input.

Both the indicator and the receiver are backlit, blue/white lighted, with easy to read numbers. Both meet FAA's Technical Standard Orders.

The indicator is 76 mm (3 in) in diameter.

The KR 87/KI 227 combination is a part of the King Silver Crown Series.

The weight increase with the Automatic Direction Finder Kit installed is 3.0 kilograms (6.6 pounds).

Installation and Maintenance Instructions. Bell or King Service Center installation is required in order to obtain King's full year warranty.

THIS IS AN UNCONTROLLED DOCUMENT. THE DATA IS PRESENTED FOR GENERAL INFORMATION ONLY. SOME INFORMATION HAS BEEN SUPERCEDED SINCE ORIGINAL PUBLICATION. PLEASE REFER TO THE CURRENT PRODUCT SPECIFICATION BOOKLET FOR UP-TO-DATE STANDARD EQUIPMENT LIST & KIT WEIGHTS, PERFORMANCE, AND DIRECT OPERATING COST.



BELL 206B JETRANGER III

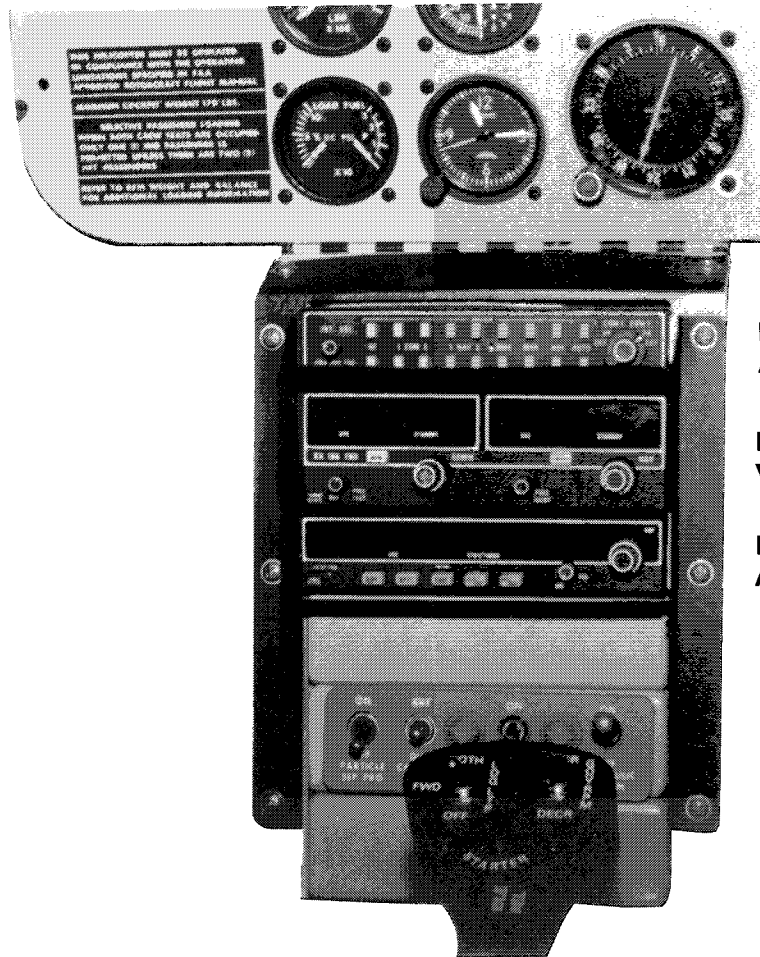

KI 227

KMA 24H
AUDIO PANEL

KX 155
VHF TRANSCEIVER

KR 87
ADF

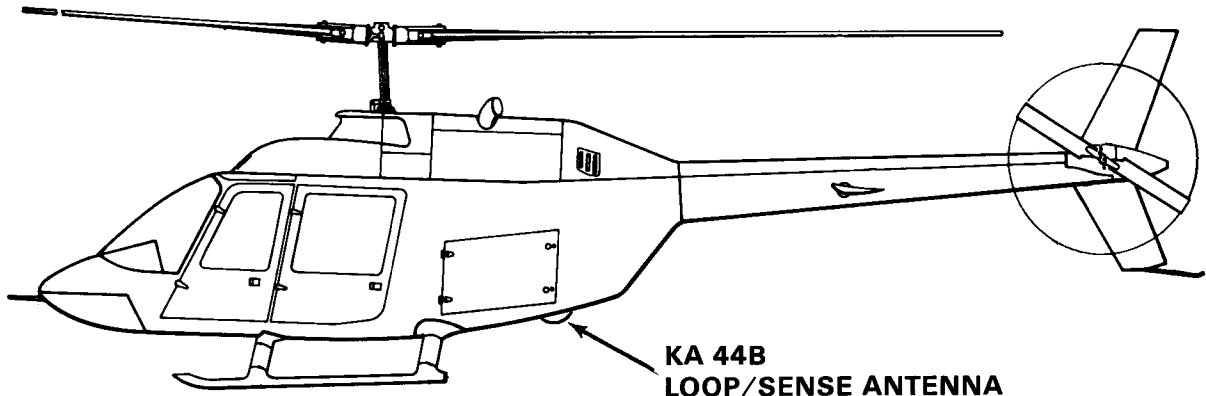

KA 44B
LOOP/SENSE ANTENNA



THIS IS AN UNCONTROLLED DOCUMENT. THE DATA IS PRESENTED FOR GENERAL INFORMATION ONLY. SOME INFORMATION HAS BEEN SUPERCEDED SINCE ORIGINAL PUBLICATION. PLEASE REFER TO THE CURRENT PRODUCT SPECIFICATION BOOKLET FOR UP-TO-DATE STANDARD EQUIPMENT LIST & KIT WEIGHTS, PERFORMANCE, AND DIRECT OPERATING COST.

BELL 206B
JETRANGER III



**TRANSPONDER
KING KT 76A**

BELL KIT NO. 206-705-008-115
PROVISIONS KIT
BELL KIT NO. 206-705-008-117
TRANSPONDER KIT

The purpose of the transponder kits is to enable the traffic controller to identify your helicopter clearly, quickly and accurately. The response to interrogation is automatic. Additional identification can be requested in which case the reply is activated by pressing the ident pushbutton.

The two separate kits - the provisions kit and the transponder kit - allow the customer complete flexibility.

The Provisions Kit, No. 206-705-008-115, consists of the KA 60 antenna and the wiring, bracket and hardware necessary to accept the King KT 76A transponder.

The Transponder Kit, No. 206-705-008-117, consists of the King KT 76A transponder, a vendor manual and warranty.

The KT 76A is a Class 1 radio transmitter/receiver operating on radar frequencies. It has adequate power for use at all operating altitudes.

The set receives ground radar interrogations at 1030 MHz and these trigger a coded response of radar pulses at 1090 MHz, which is transmitted back to the ground radar.

It responds in any of 4096 preselected "codes". Codes differ only in number of pulses transmitted, not in frequency. Transmitter frequency remains always at 1090 MHz. The assigned code, or emergency codes, are easily set and appear as digits in the four code windows.

The transponder's coded reply pulses reinforce the normal "blip" which appears on air traffic control radar. When the IDENT button is pressed, the blip will flash or "bloom" so the controller can positively identify the aircraft and its location.

The transponder has blue/white lighting and green reply light. The automatic dimming feature matches its intensity

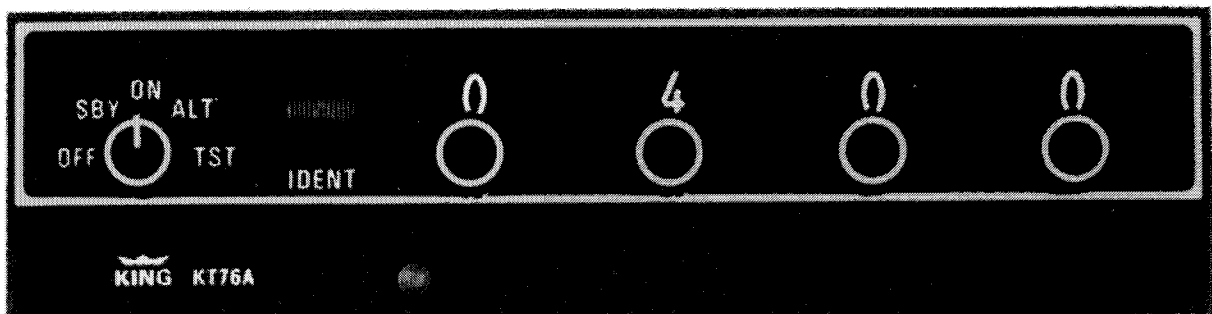



THIS IS AN UNCONTROLLED DOCUMENT. THE DATA IS PRESENTED FOR GENERAL INFORMATION ONLY. SOME INFORMATION HAS BEEN SUPERCEDED SINCE ORIGINAL PUBLICATION. PLEASE REFER TO THE CURRENT PRODUCT SPECIFICATION BOOKLET FOR UP-TO-DATE STANDARD EQUIPMENT LIST & KIT WEIGHTS, PERFORMANCE, AND DIRECT OPERATING COST.

BELL 206B JETRANGER III

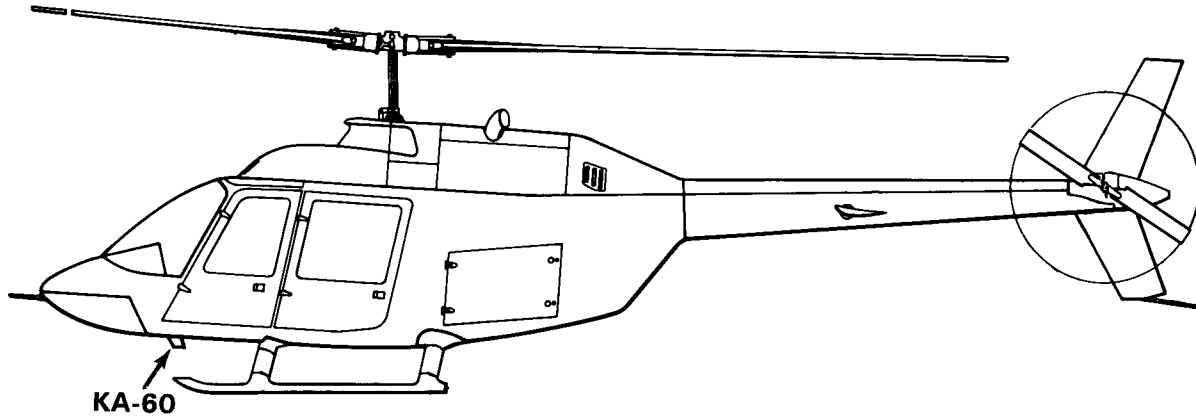

to the cockpit lighting conditions. KT 76A dimensions are 15.87 X 4.14 X 25.4 centimeters (6.25 X 1.63 X 10.0 inches). It is panel mounted and it meets FAA Technical Standard Orders.

The weight increase with the provisions installed is 0.4 kilograms (0.9 pounds). With the complete installation it is 1.68 kilograms (3.72 pounds).

Installation and Maintenance Instructions. Bell or King Service Center installation is required to obtain the King full year warranty.



THIS IS AN UNCONTROLLED DOCUMENT. THE DATA IS PRESENTED FOR GENERAL INFORMATION ONLY. SOME INFORMATION HAS BEEN SUPERCEDED SINCE ORIGINAL PUBLICATION. PLEASE REFER TO THE CURRENT PRODUCT SPECIFICATION BOOKLET FOR UP-TO-DATE STANDARD EQUIPMENT LIST & KIT WEIGHTS, PERFORMANCE, AND DIRECT OPERATING COST.

BELL 206B JETRANGER III

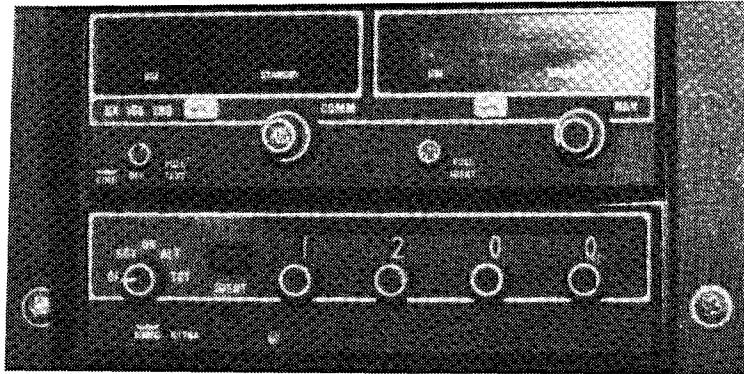

Typical installations

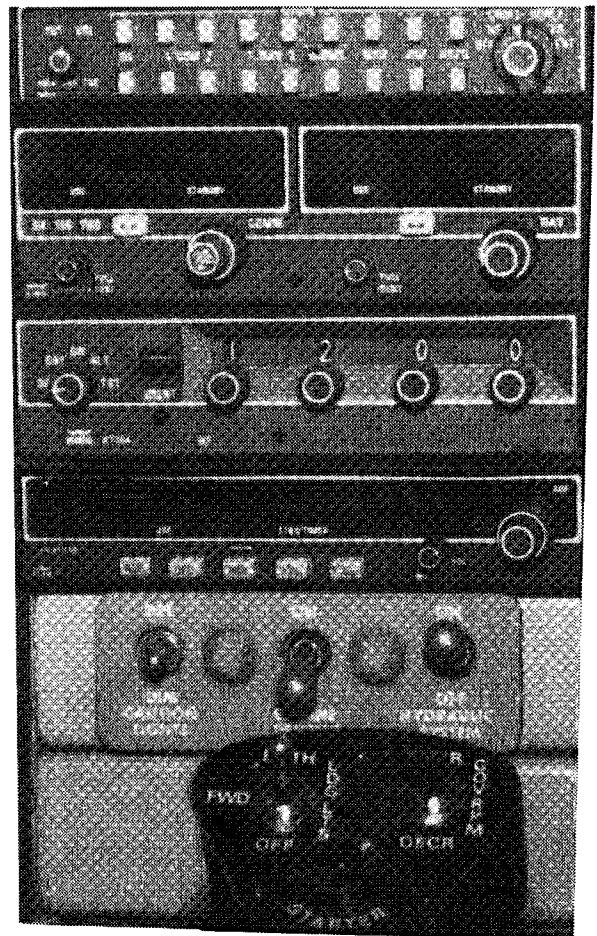
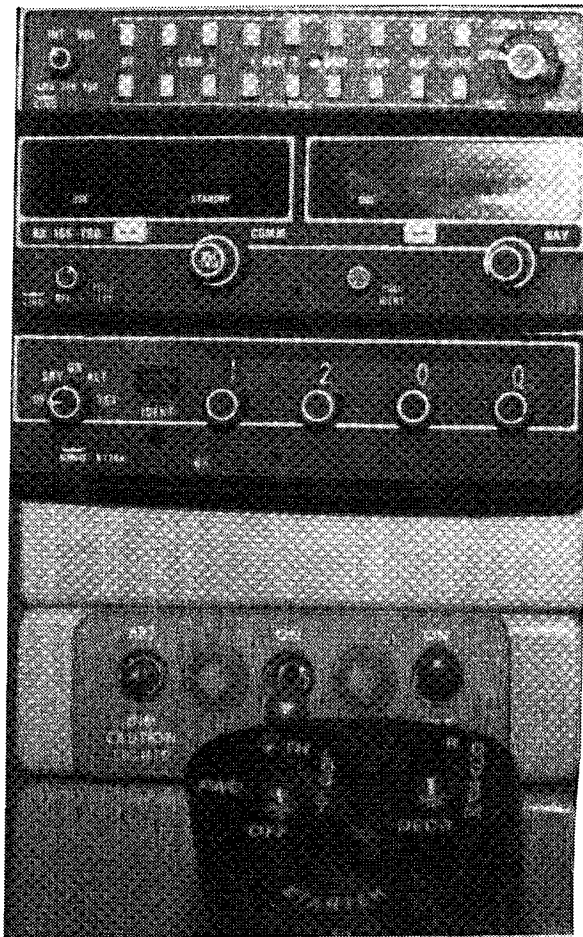



THIS IS AN UNCONTROLLED DOCUMENT. THE DATA IS PRESENTED FOR GENERAL INFORMATION ONLY. SOME INFORMATION HAS BEEN SUPERCEDED SINCE ORIGINAL PUBLICATION. PLEASE REFER TO THE CURRENT PRODUCT SPECIFICATION BOOKLET FOR UP-TO-DATE STANDARD EQUIPMENT LIST & KIT WEIGHTS, PERFORMANCE, AND DIRECT OPERATING COST.

BELL 206B
JETRANGER III



AUXILIARY BATTERY

BELL KIT NO. 206-706-330-011

The purpose of the Auxiliary Battery kit is to provide increased starting capability. It is particularly useful in cold weather and when the flight schedule calls for many short trips and frequent start-ups, such as in a primary training school.

The battery, identical to the standard battery, is installed in the baggage compartment, in parallel with the standard battery. A switch on the radio pedestal permits selection of either battery or both.

The kit consists of a 13 ampere-hour battery, brackets, cables, vent tubes, relays, caution lights and attaching hardware.

The weight increase with the Auxiliary Battery kit installed is 15 kilograms (31.8 pounds).

Flight Procedures are contained in the Flight Manual Supplement.

Allowable weight in the baggage compartment is restricted to a maximum of 99.8 kilograms (220 pounds) when the battery is installed.

The amber caution light AUX BATTERY TEMP illuminates when the auxiliary battery temperature reaches 54.5°C (130°F). The red AUX BATTERY HOT illuminates when the temperature reaches 60°C (140°F).

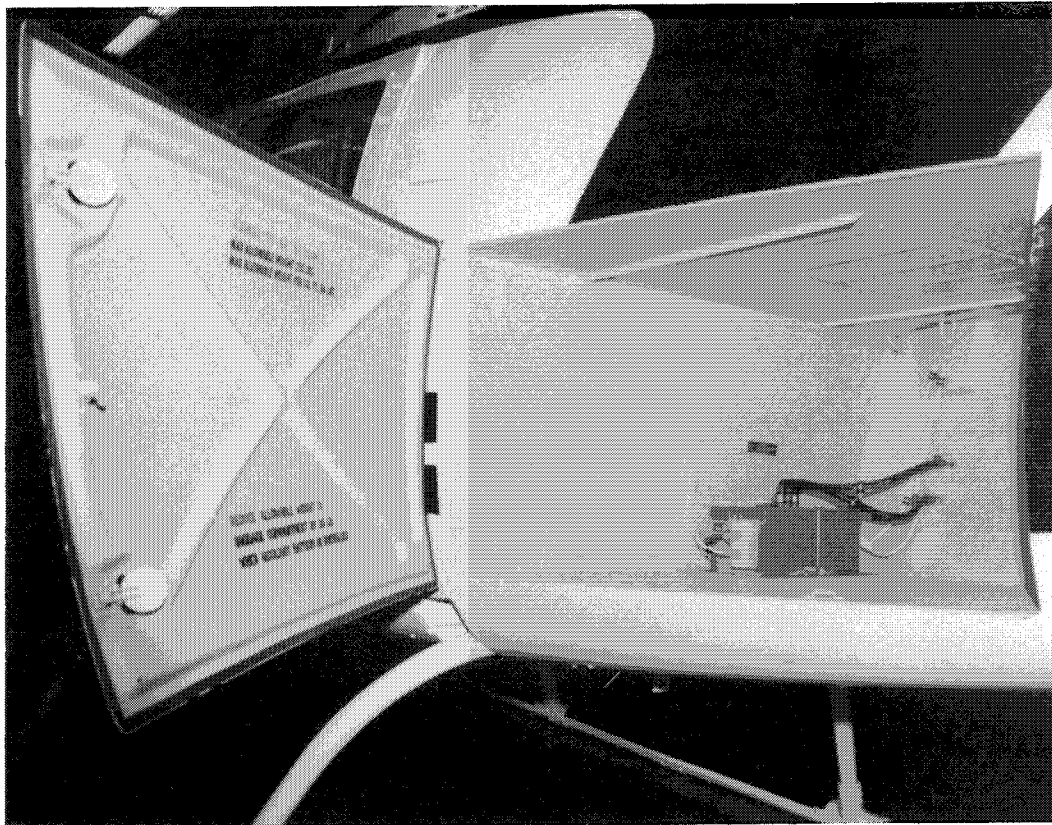

02272



THIS IS AN UNCONTROLLED DOCUMENT. THE DATA IS PRESENTED FOR GENERAL INFORMATION ONLY. SOME INFORMATION HAS BEEN SUPERCEDED SINCE ORIGINAL PUBLICATION. PLEASE REFER TO THE CURRENT PRODUCT SPECIFICATION BOOKLET FOR UP-TO-DATE STANDARD EQUIPMENT LIST & KIT WEIGHTS, PERFORMANCE, AND DIRECT OPERATING COST.

BELL 206B JETRANGER III

SELECTOR SWITCH ON MISCELLANEOUS CONTROL PANEL

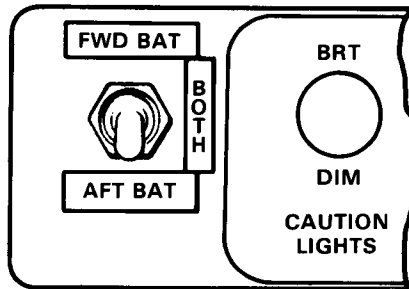

CAUTION PANEL

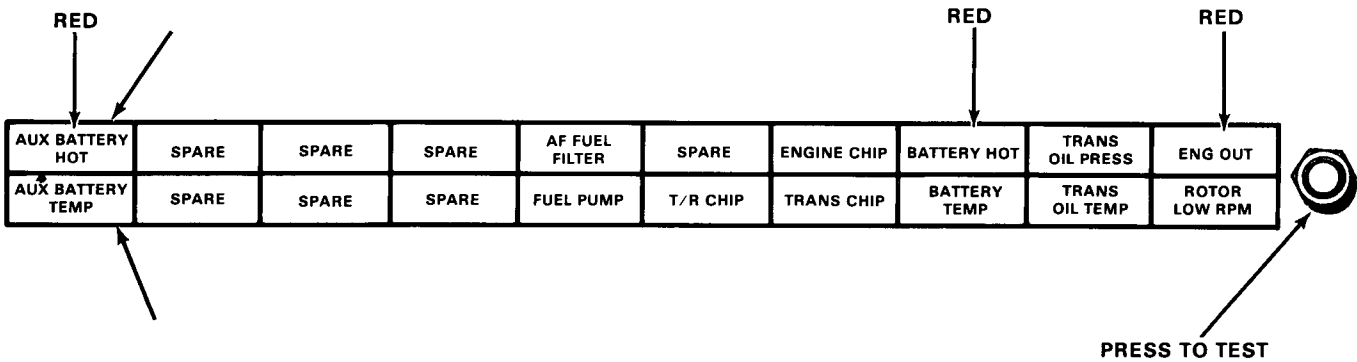

Installation and Maintenance Instructions are contained in Bell Service Instruction 206-78.

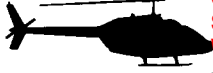

HEAVY DUTY BATTERY

BELL KIT NO. 206-706-738-101

The purpose of the Heavy Duty Battery kit is to provide increased starting capability without installing a second battery. The added power is particularly useful in cold weather and when the flight schedule calls for many short trips and frequent start-ups, such as in a primary training school.

The heavy duty battery replaces the standard 13 ampere hour battery in the nose of the helicopter.

The heavy duty battery is connected to the aircraft electrical system with an Elcon type quick disconnect.

The kit consists of a nickel-cadmium, vented, 24 volt 17 ampere-hour battery and the hardware necessary to mount the larger unit in the nose.

The weight increase with the heavy duty battery installed is 5.9 kilograms (13 pounds).

Installation and Maintenance Instructions are contained in the Bell Service Instruction 206-116.

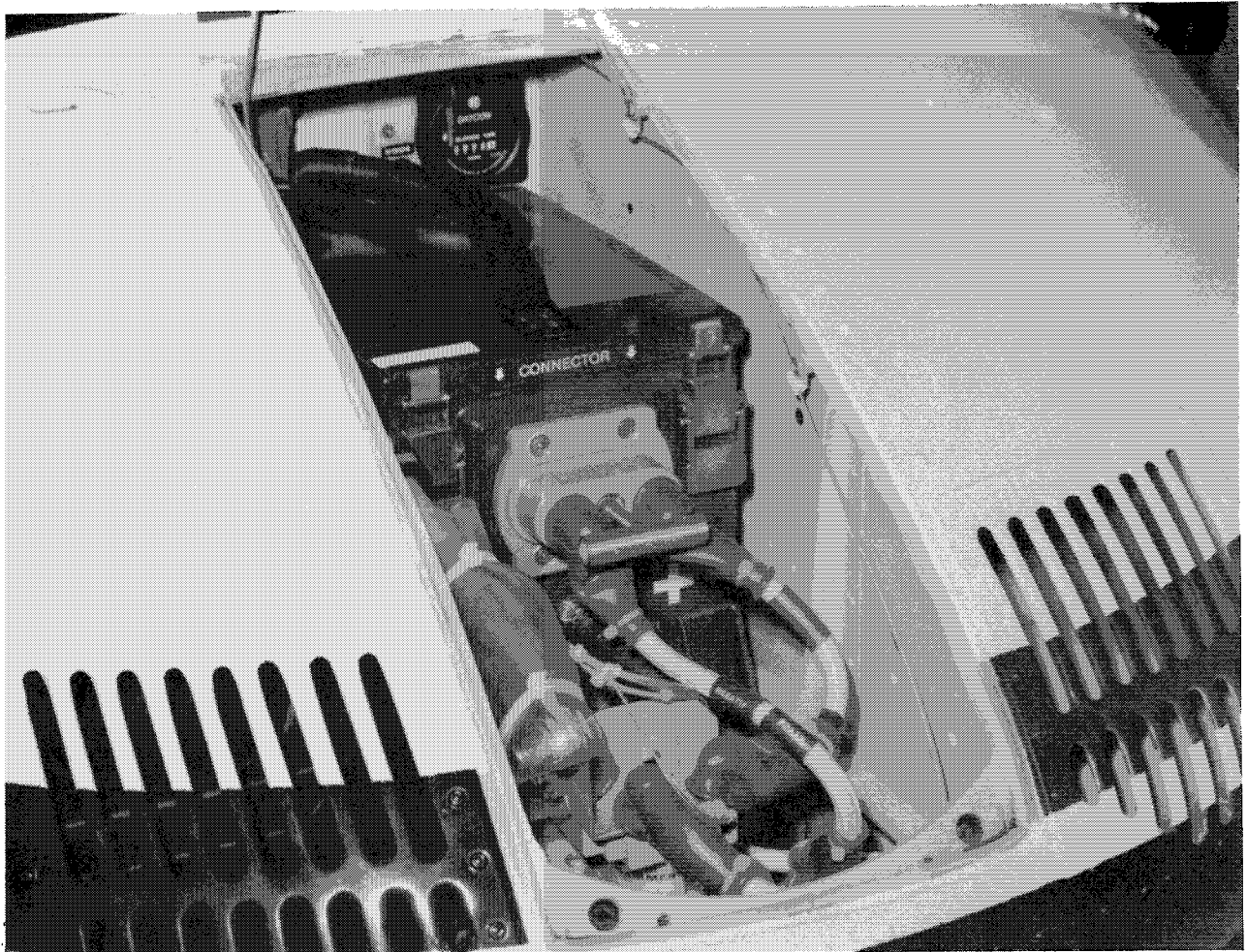



THIS IS AN UNCONTROLLED DOCUMENT. THE DATA IS PRESENTED FOR GENERAL INFORMATION ONLY. SOME INFORMATION HAS BEEN SUPERCEDED SINCE ORIGINAL PUBLICATION. PLEASE REFER TO THE CURRENT PRODUCT SPECIFICATION BOOKLET FOR UP-TO-DATE STANDARD EQUIPMENT LIST & KIT WEIGHTS, PERFORMANCE, AND DIRECT OPERATING COST.

BELL 206B
JETRANGER III



CUSTOM DELUXE INTERIORS

BELL KIT NO. 206-705-102-XXX
SEATS
AND 206-705-300-XXX
CARPETING

The purpose of the Custom Deluxe Interior kit is to satisfy the frequent requests for a more distinguished interior than the Deluxe Interior of the standard JetRanger.

The kit does not change the 5-place layout. It simply replaces the upholstery, adds interior trim, extends the carpeted areas and provides a few additional passenger conveniences.

The Custom Deluxe Interior adds additional luxury to the Deluxe Interior. The "soft look" seats, upholstered in fine fabrics or leathers, add to the elegant feeling of the interior.

The kit consists of:

- two overhead reading lights incorporated in the headliner. They are individually adjustable for direction and can be separately turned on or off.
- leather covered storage pockets mounted on the bulkhead behind the pilot and forward passenger.
- leather covered arm rests on the cabin doors.
- carpet inserts on the lower areas of all the doors.



023730



The seats for the Custom Deluxe Interiors use the standard metal frames and padding, but are covered in fabric of higher quality and are trimmed in leather. Five attractive color combinations are available. The carpet is color-coordinated to complement the colors selected for the seats.

The Bell representative has a book of actual samples to aid in the final selection.

The Custom Deluxe kit number 206-705-102-XXX applies to the seats and interior trim. 206-705-300-XXX designates the carpet.

The XXX's are replaced by the number of the selected color. These are:

	Seats	Carpets*
Sage	162	109 & 309
Antelope	164	110 & 310
Blueberry	166	111 & 311
Henna	168	112 & 312
Mist	170	113 & 313

The weight increase with the Custom Deluxe interior installed is 0.5 kilograms (1 pound).

Installation is normally completed at the factory on initial order.

To complement the selected color scheme, the interior is trimmed with ABS panels in a pleasing, neutral off-white and beige with deep tone highlights. Seat belts, harnesses and shoulder straps are in jet black nylon.

*Both carpet numbers must be called out to designate a Custom Deluxe Carpet Installation.



THIS IS AN UNCONTROLLED DOCUMENT. THE DATA IS PRESENTED FOR GENERAL INFORMATION ONLY. SOME INFORMATION HAS BEEN SUPERCEDED SINCE ORIGINAL PUBLICATION. PLEASE REFER TO THE CURRENT PRODUCT SPECIFICATION BOOKLET FOR UP-TO-DATE STANDARD EQUIPMENT LIST & KIT WEIGHTS, PERFORMANCE, AND DIRECT OPERATING COST.

BELL 206B JETRANGER III



025251



025250



025245



023626



THIS IS AN UNCONTROLLED DOCUMENT. THE DATA IS PRESENTED FOR GENERAL INFORMATION ONLY. SOME INFORMATION HAS BEEN SUPERCEDED SINCE ORIGINAL PUBLICATION. PLEASE REFER TO THE CURRENT PRODUCT SPECIFICATION BOOKLET FOR UP-TO-DATE STANDARD EQUIPMENT LIST & KIT WEIGHTS, PERFORMANCE, AND DIRECT OPERATING COST.

BELL 206B
JETRANGER III



THIS IS AN UNCONTROLLED DOCUMENT. THE DATA IS PRESENTED FOR GENERAL INFORMATION ONLY. SOME INFORMATION HAS BEEN SUPERCEDED SINCE ORIGINAL PUBLICATION. PLEASE REFER TO THE CURRENT PRODUCT SPECIFICATION BOOKLET FOR UP-TO-DATE STANDARD EQUIPMENT LIST & KIT WEIGHTS, PERFORMANCE, AND DIRECT OPERATING COST.

BELL 206B
JETRANGER III

MESH SEATS

BELL KIT NO. 206-705-011-101

The purpose of the Mesh Seats kit is to provide cooler seats for the pilot and passengers yet retain the comfort and durability of the standard interior. There is no change in the seating arrangement. Every seat and seatback is constructed with a large open-weave panel which permits full air circulation.

The kit consists of five seats and seatbacks which replace the standard frame without any modification to the airframe, seat belts or trim.

The kit is available in tan.



024201



THIS IS AN UNCONTROLLED DOCUMENT. THE DATA IS PRESENTED FOR GENERAL INFORMATION ONLY. SOME INFORMATION HAS BEEN SUPERCEDED SINCE ORIGINAL PUBLICATION. PLEASE REFER TO THE CURRENT PRODUCT SPECIFICATION BOOKLET FOR UP-TO-DATE STANDARD EQUIPMENT LIST & KIT WEIGHTS, PERFORMANCE, AND DIRECT OPERATING COST.

**BELL 206B
JETRANGER III**



024359



310277



024203



025207



THIS IS AN UNCONTROLLED DOCUMENT. THE DATA IS PRESENTED FOR GENERAL INFORMATION ONLY. SOME INFORMATION HAS BEEN SUPERCEDED SINCE ORIGINAL PUBLICATION. PLEASE REFER TO THE CURRENT PRODUCT SPECIFICATION BOOKLET FOR UP-TO-DATE STANDARD EQUIPMENT LIST & KIT WEIGHTS, PERFORMANCE, AND DIRECT OPERATING COST.

BELL 206B JETRANGER III



025206

The fabric and mesh construction uses identical frames with built in lumbar support. However, the additional lumbar adjustment, a feature in the standard crew seats, is not possible.

The weight decrease with the Mesh Seats kit installed is 1.4 kilograms (minus 3 pounds).

Installation is normally completed at the factory on initial order.

STANDARD PROVISIONS



024205



THIS IS AN UNCONTROLLED DOCUMENT. THE DATA IS PRESENTED FOR GENERAL INFORMATION ONLY. SOME INFORMATION HAS BEEN SUPERCEDED SINCE ORIGINAL PUBLICATION. PLEASE REFER TO THE CURRENT PRODUCT SPECIFICATION BOOKLET FOR UP-TO-DATE STANDARD EQUIPMENT LIST & KIT WEIGHTS, PERFORMANCE, AND DIRECT OPERATING COST.

BELL 206B
JETRANGER III



SPECIAL INTERIORS

In addition to the standard deluxe interior and the custom deluxe kit, Bell Helicopter Textron has designed and finished the JetRanger in a wide variety of customized styles to match a customer's existing transport fleet, highlight his company colors, or to meet any other specific needs.

The Standard Deluxe seats can be finished completely in vinyl, adding 5.9 kilograms (13 pounds) to the standard configuration.

These can be finished in any of the available colors.

The numbers of the all-vinyl kits are as follows:

206-705-101-108 in tan
206-705-101-110 in brown
206-705-101-112 in blue
206-705-101-114 in red

Carpet numbers are listed in the Custom Deluxe Interiors description on page 3-72.

The Custom Deluxe seats can be finished completely in leather. Colors are available. This adds 6.8 kilograms (15 pounds) to the standard configuration - half a kilogram more than the Custom Deluxe kits.



013985



THIS IS AN UNCONTROLLED DOCUMENT. THE DATA IS PRESENTED FOR GENERAL INFORMATION ONLY. SOME INFORMATION HAS BEEN SUPERCEDED SINCE ORIGINAL PUBLICATION. PLEASE REFER TO THE CURRENT PRODUCT SPECIFICATION BOOKLET FOR UP-TO-DATE STANDARD EQUIPMENT LIST & KIT WEIGHTS, PERFORMANCE, AND DIRECT OPERATING COST.

BELL 206B JETRANGER III

The numbers of the all-leather kits are as follows:

206-705-102-163 in tan
206-705-102-165 in brown
206-705-102-167 in blue
206-705-102-169 in red
206-705-102-171 in grey

Carpet numbers are listed in the Custom Deluxe Interiors description on page 3-72.



All leather

025248

For a lightweight utility configuration, cushions, usually a single three-place design, can be used on the rear seat bench instead of the standard seat frames.

Special interiors cover a wide range of furnishings such as desks and bars, additional lighting, business communications, larger window openings, extra hand holds, etc. A popular group has been intensive care interiors. The variations are endless.



Customized avionics

024538



CUSTOM SOUNDPROOFING BLANKETS

BELL KIT NO. 206-706-039-103

The purpose of the Custom Soundproofing Blankets kit is to reduce the cabin noise level by 3dBA. The installation is not visible since the extra blankets are covered by the same headliner and trim panels.

The kit consists of six blankets and the tape and hardware to complete the installation. One blanket replaces the standard ceiling blanket and one replaces the standard single blanket behind the parcel shelf. Two others ring

the sides and roof of the shelf area and the remaining pair go in the forward cabin roof.

The custom soundproofing blankets are all made with a lead/vinyl center and a fiberglass batting. Each is quilted with a cotton muslin cover.

The weight increase with the Custom Soundproofing Blankets installed is 10.9 kilograms (24 pounds).

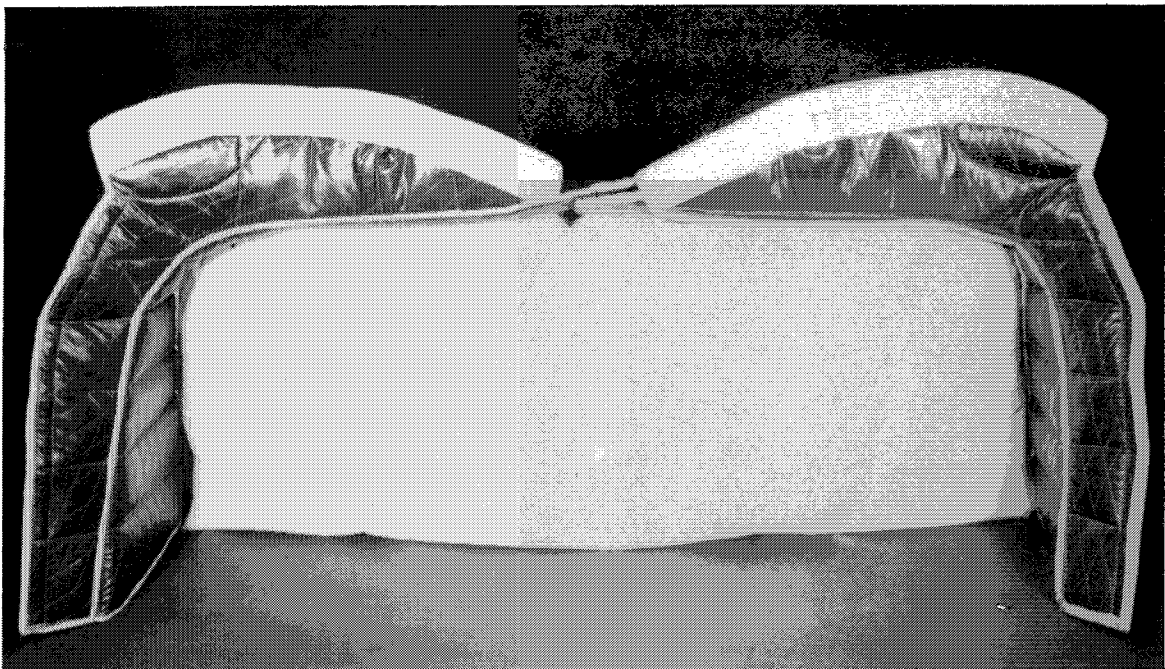

01367



THIS IS AN UNCONTROLLED DOCUMENT. THE DATA IS PRESENTED FOR GENERAL INFORMATION ONLY. SOME INFORMATION HAS BEEN SUPERCEDED SINCE ORIGINAL PUBLICATION. PLEASE REFER TO THE CURRENT PRODUCT SPECIFICATION BOOKLET FOR UP-TO-DATE STANDARD EQUIPMENT LIST & KIT WEIGHTS, PERFORMANCE, AND DIRECT OPERATING COST.

BELL 206B
JETRANGER III

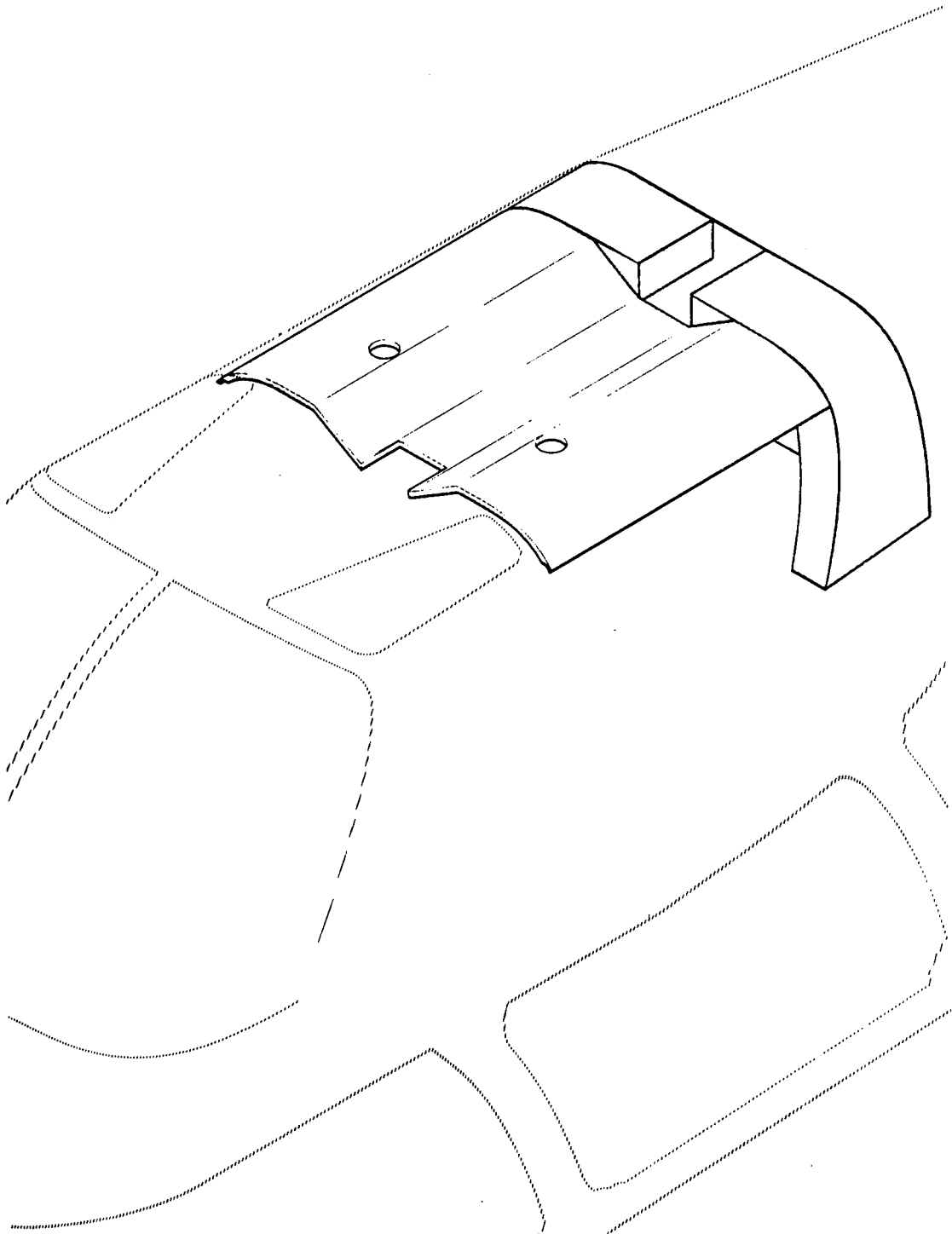



BLEED-AIR HEATER

BELL KIT NO. 206-706-700-101

The purpose of the Bleed-Air Heater Kit is to provide forced air, heated to the selected temperature, throughout the forward and passenger compartments and to the windshields.

The Kit consists of a patented air mixing valve incorporating a solenoid-actuated bleed-air shut off valve, ducts, electrical system, noise suppressor, adjustable outlets to direct the flow of heated air, heater controls, and the necessary installation hardware.

The heater is installed in the equipment compartment which is directly above the baggage compartment and behind the interior cabin shelf. A fresh air inlet is installed on the left side of the fuselage.

The temperature is manually controlled.

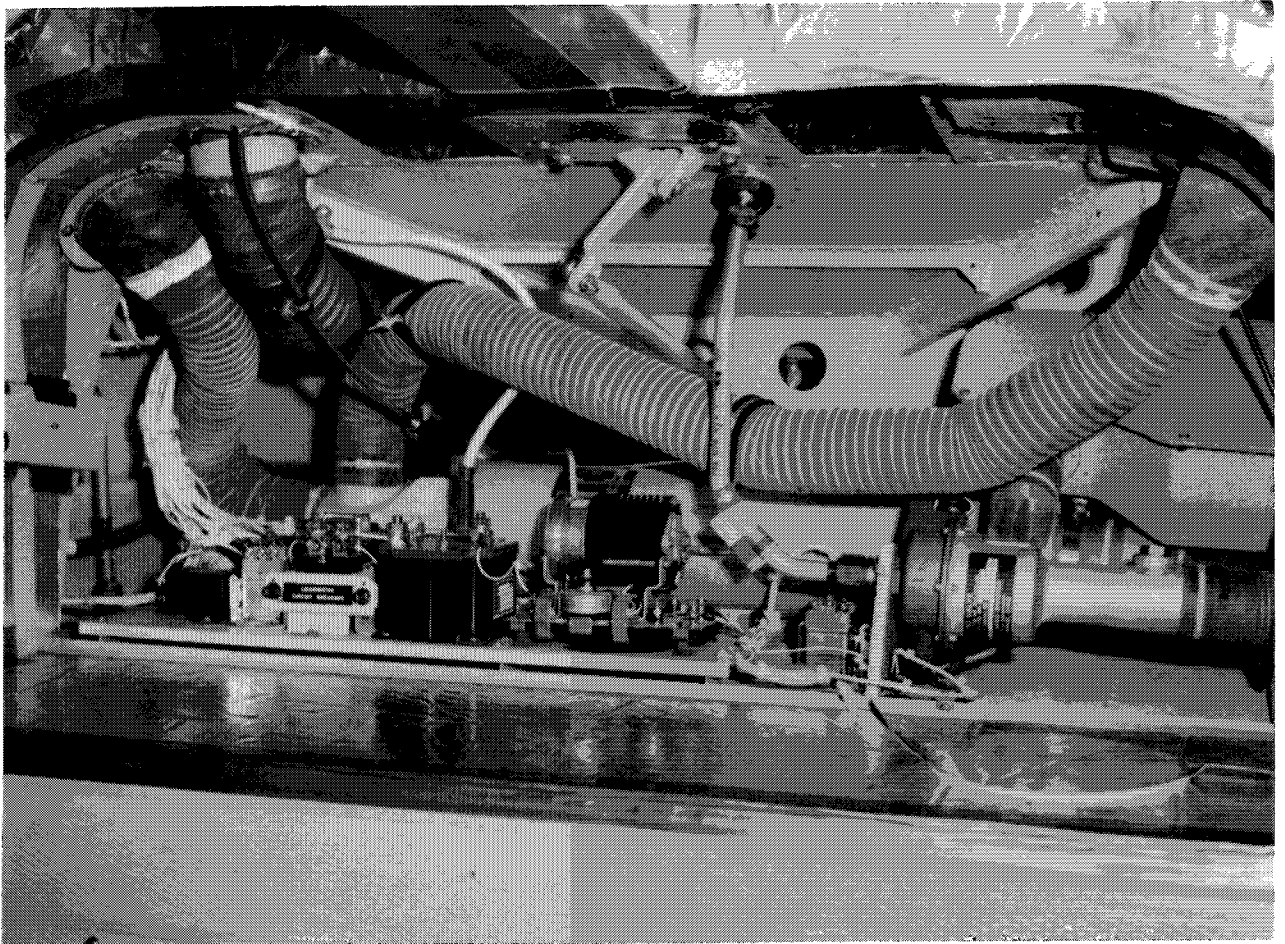

02279



Typical performance of the heater kit is shown in the figure below. The cabin temperature is shown as a function of outside air temperature. Heating performance is based on engine bleed air pressure and temperature; therefore, heating curves are shown for flat pitch and MCP (maximum continuous power) operation.

For example, if the outside temperature is -30°C , the chart indicates that the heater can provide a comfortable cabin temperature of 19°C while flying at maximum continuous power.

On the ground at an outside temperature of -20°C a temperature of 9°C can be maintained in the cabin.

Fresh air is drawn into the heater through the scoop shaped port on the left side of the fuselage and passes through a noise suppressor. It is then automatically mixed with a quantity of bleed air measured to meet the temperature set on the pilot's temperature selector. The temperature selector is conveniently mounted on the

upper right side of the control tunnel. It is turned clockwise for more heat. The heated air is distributed through a noise suppressor and into the ducts. Four adjustable distribution outlets are located in the lower forward compartment and two in the lower passenger compartment.

A circuit breaker is mounted on the overhead panel. An overheat switch in the heater duct trips the circuit breaker if the heat exceeds the set maximum. This in turn activates the solenoid which shuts off the bleed air.

When the roof mounted defogger doors are opened individually, heated air is vectored directly to the windshields. The doors are adjustable to permit control of the intensity of this defogging action.

The weight increase with the bleed-air heater kit installed is 15 kilograms (33 pounds).

Installation and Maintenance Instructions are contained in Bell Service Instruction 206-118.

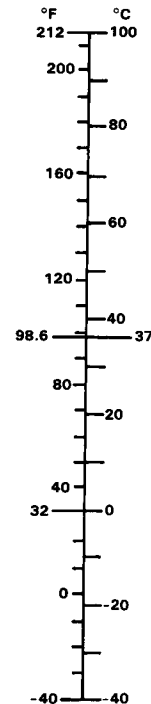
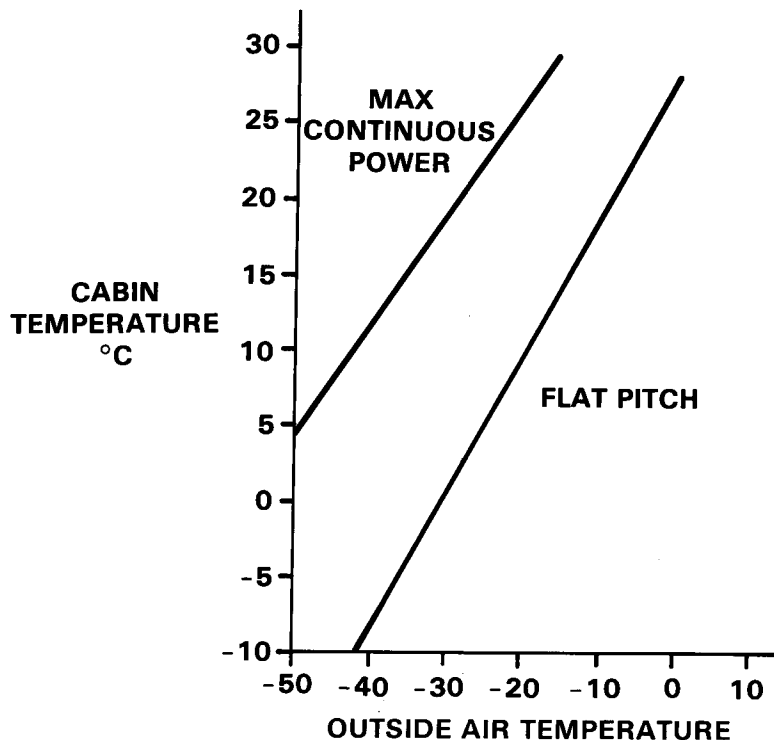

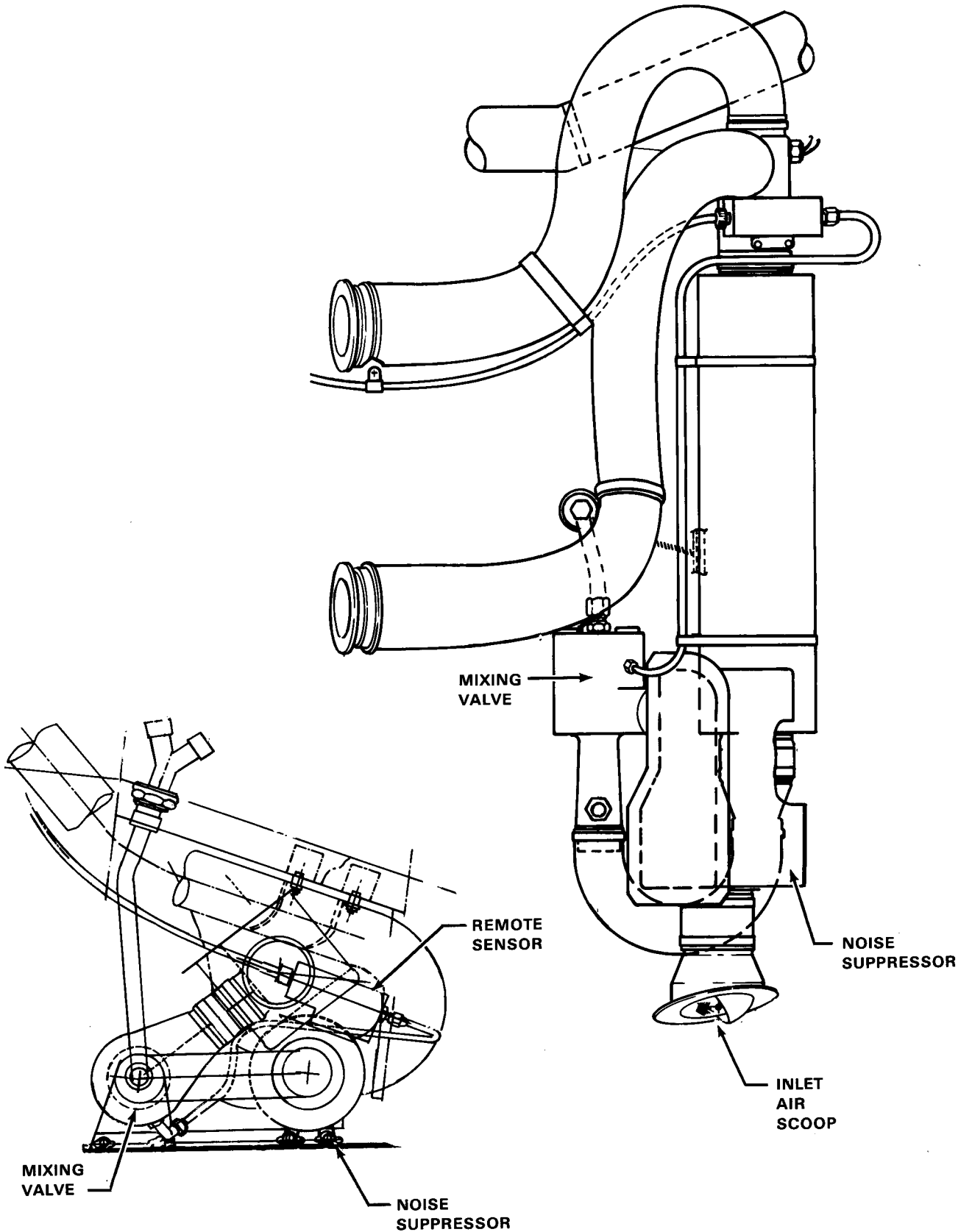
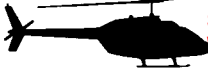



THIS IS AN UNCONTROLLED DOCUMENT. THE DATA IS PRESENTED FOR GENERAL INFORMATION ONLY. SOME INFORMATION HAS BEEN SUPERCEDED SINCE ORIGINAL PUBLICATION. PLEASE REFER TO THE CURRENT PRODUCT SPECIFICATION BOOKLET FOR UP-TO-DATE STANDARD EQUIPMENT LIST & KIT WEIGHTS, PERFORMANCE, AND DIRECT OPERATING COST.

BELL 206B
JETRANGER III

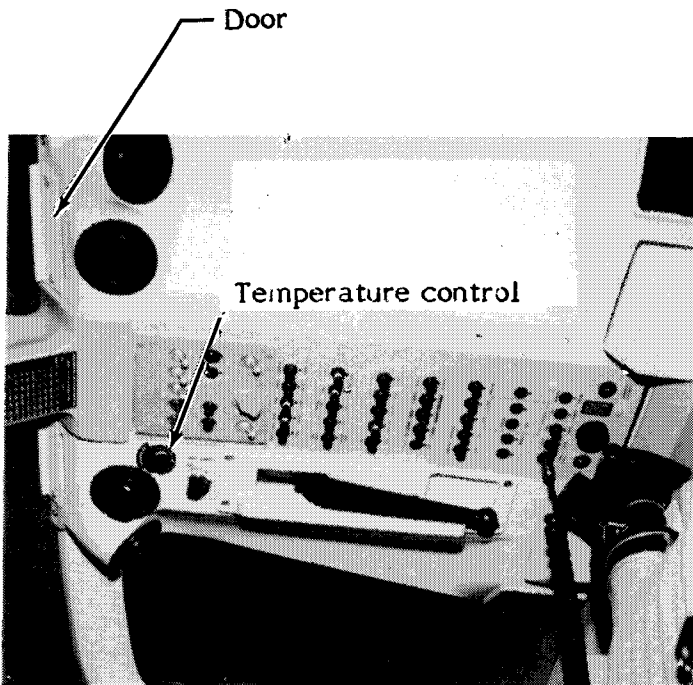
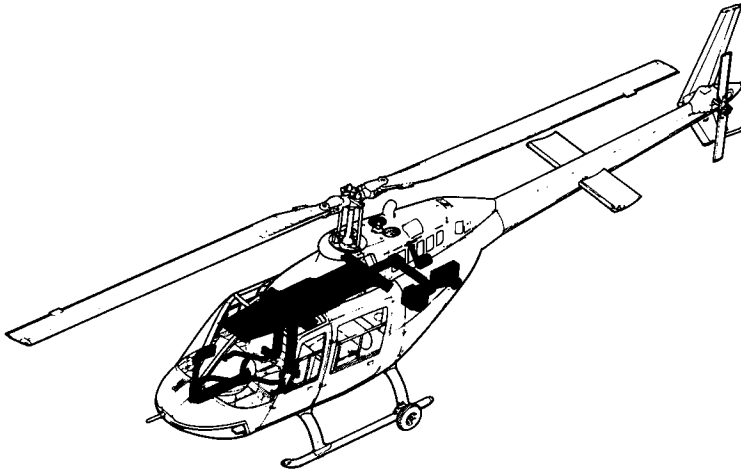

025268

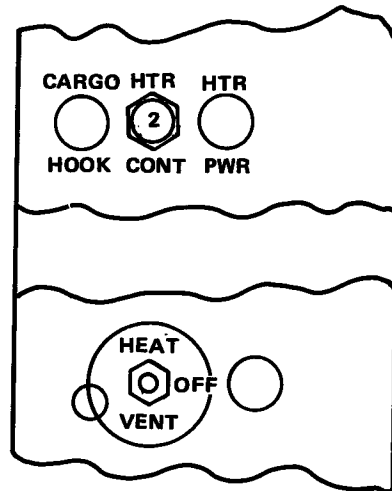



THIS IS AN UNCONTROLLED DOCUMENT. THE DATA IS PRESENTED FOR GENERAL INFORMATION ONLY. SOME INFORMATION HAS BEEN SUPERCEDED SINCE ORIGINAL PUBLICATION. PLEASE REFER TO THE CURRENT PRODUCT SPECIFICATION BOOKLET FOR UP-TO-DATE STANDARD EQUIPMENT LIST & KIT WEIGHTS, PERFORMANCE, AND DIRECT OPERATING COST.

BELL 206B
JETRANGER III

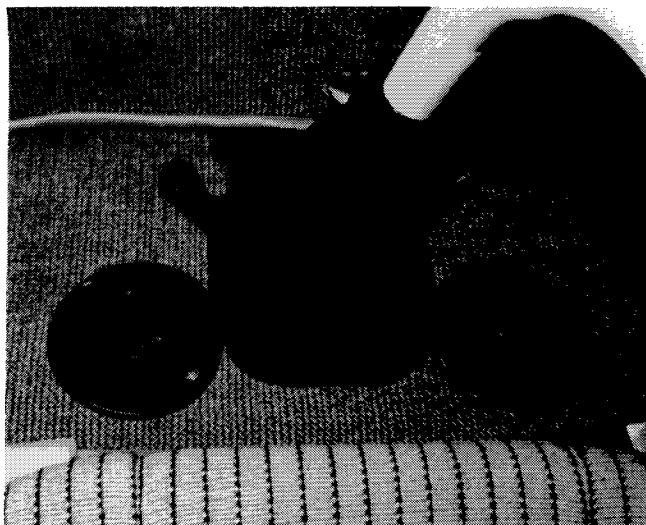

025279



025247



THIS IS AN UNCONTROLLED DOCUMENT. THE DATA IS PRESENTED FOR GENERAL INFORMATION ONLY. SOME INFORMATION HAS BEEN SUPERCEDED SINCE ORIGINAL PUBLICATION. PLEASE REFER TO THE CURRENT PRODUCT SPECIFICATION BOOKLET FOR UP-TO-DATE STANDARD EQUIPMENT LIST & KIT WEIGHTS, PERFORMANCE, AND DIRECT OPERATING COST.

BELL 206B
JETRANGER III



ENVIRONMENTAL CONTROL SYSTEM

BELL KIT NO. 206-705-400-101
PROVISIONS KIT
PARKER-HANNIFIN KIT NO. 206-0100-7
ENVIRONMENTAL CONTROL UNIT KIT

The purpose of the Environmental Control System kits is to provide a comfortable environment for the pilot and passengers when working in severe operational environments.

Comfort increases the productivity of the crew when the long airborne mission demands a high level of alertness.

The installation is a completely integrated heating and cooling system which provides a precisely controlled cabin temperature, automatically. The desired temperature is easily set and can be changed at will.

Air circulation can be adjusted by directional, volume-adjustable nozzles

that are appropriately and conveniently placed and by the high/low fan controls.

In addition to temperature control, the system further improves the comfort level by removing moisture from the circulating air.

The system can be operated only when the engine is running since the heating components use bleed air and the compressor for cooling is engine driven.

The compressor, driven off the tail rotor drive is easily accessible.

The installation does not encroach on cabin or baggage space. It is of minimum weight for high, reliable



025277



performance and uses minimum mechanical and electrical power. The cooling system requires 5 horsepower and the normal electrical requirement is 54 amperes.

The two separate kits - the Bell Helicopter Textron Provisions Kit and the Parker Hannifin Environmental Control Unit Kit - provides the most economical package for the installation.

The Environmental Control System Provisions Kit, No. 206-705-400-101, consists of the ducting and controllable vents to distribute the conditioned air throughout the cabin.

The ducting carries the conditioned air from the equipment compartment, forward, along the center of the cabin ceiling. A pair of outlets are mounted at each side of the vertical control tunnel in the aft cabin and a single one on each side in the forward cabin. A port on each side directs airflow to the windshield. Each port has an adjustable door.

Ducts down each side of the tunnel carry the air to an outlet, at floor level, in the aft cabin, one on each side, and to the outlets mounted on the forward face of the crew seat bench, at floor level, one at each seat position.

The Environmental Control Unit Kit, No. 206-0100-26, consists of a vapor cycle, airborne conditioning system of carefully matched components, the ducting, blower and ventilators to mount controllable outlets on each side of the instrument panel, a bleed air heater and the necessary controls, electrical components, plumbing and hardware to complete the installation.

The conditioning system is rated at a maximum of 30,000 BTUH/400 cubic feet per minute and consists of:

- a belt driven compressor with a self-contained oil system, mounted in the engine compartment
- a condenser/blower, electrically driven, in the equipment shelf
- an evaporator in the equipment shelf
- an electrically driven evaporation blower in the equipment shelf, which provides circulation air for the cooling system and can augment the air flow when the heater is in use

The ventilators on the instrument panel are fed by ducting that is connected to the control tunnel ducts. The ducts then go forward under the floor, pass through a blower and terminate in the ventilators. Air flow can be directed aft to the crew or downward to defog the chin bubbles.

The bleed air heater rated at a maximum of 30,000 BTUH is mounted on the equipment shelf. It has an integral silencer and a DUCT TEMP HIGH caution light.

Controls for the cooling units are mounted on a panel on the radio pedestal. Three switches are provided:

- air conditioner or fan
- hi/lo blower speed
- temperature control

The control for the heating unit is mounted on the forward cabin ceiling. It consists of an OFF/MAX rotary control on which the desired temperature is set.

The weight increase with the complete Environmental Control System installed is 39.5 kilograms (87 pounds).



Flight Procedures and performance data are contained in the Flight Manual Supplement.

The system uses R-12 freon refrigerant. R-12 is non-explosive, non-inflammable, non-corrosive, practically odorless and heavier than air.

When the system is turned on, the compressor compresses freon gas to a high pressure and temperature. This gas is routed to the condenser where cooling from the fan removes heat from the gas, condensing it into a liquid. The liquid is then stored in the receiver/dryer next to the evaporator until it is used. The freon is metered through the evaporator by the expansion valve at a rate which allows all the liquid to evaporate and return to the compressor at a reduced pressure. The cabin heat is absorbed from the air passing over the evaporator cooling fans.

The bleed air heater systems consists of the following components:

- The heat control is located on the pilot's overhead panel. Rotating the control knob clockwise turns the heat on and increases the temperature. Turning it counter-clockwise reduces the temperature and turns the heat off.
- The regulator valve is located on the equipment shelf. The valve delivers bleed air as directed by the heat control setting, to the ejector nozzle located internal to the heater silencer via a flex duct.
- The heater silencer is located just above the access panel in the baggage compartment. Bleed air delivered to the nozzle creates a positive hot air flow to the cabin.

This can be augmented by the evaporation blower. A duct temperature switch, when activated, illuminates a light on the instrument caution panel labeled "DUCT TEMP HIGH".

Installation and Maintenance Instructions for the units are contained in the Parker-Hannifin manual no. 206-0100-26M.

Paker-Hannifin support is world-wide.

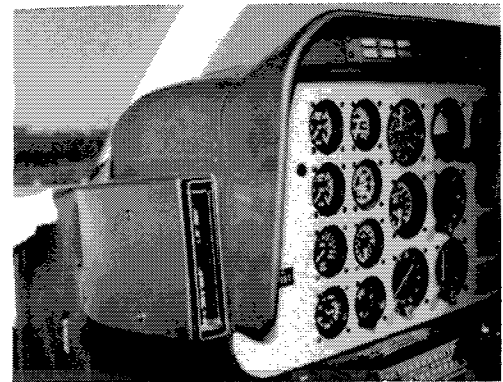

025264



025256



025257



THIS IS AN UNCONTROLLED DOCUMENT. THE DATA IS PRESENTED FOR GENERAL INFORMATION ONLY. SOME INFORMATION HAS BEEN SUPERCEDED SINCE ORIGINAL PUBLICATION. PLEASE REFER TO THE CURRENT PRODUCT SPECIFICATION BOOKLET FOR UP-TO-DATE STANDARD EQUIPMENT LIST & KIT WEIGHTS, PERFORMANCE, AND DIRECT OPERATING COST.

BELL 206B
JETRANGER III

TYPICAL AIR CONDITIONING RESPONSE

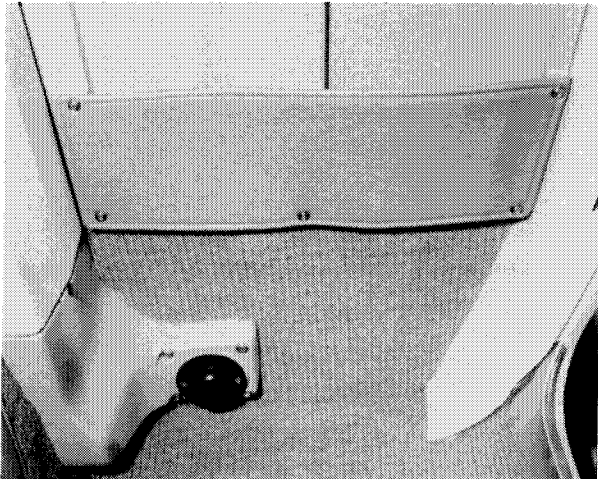
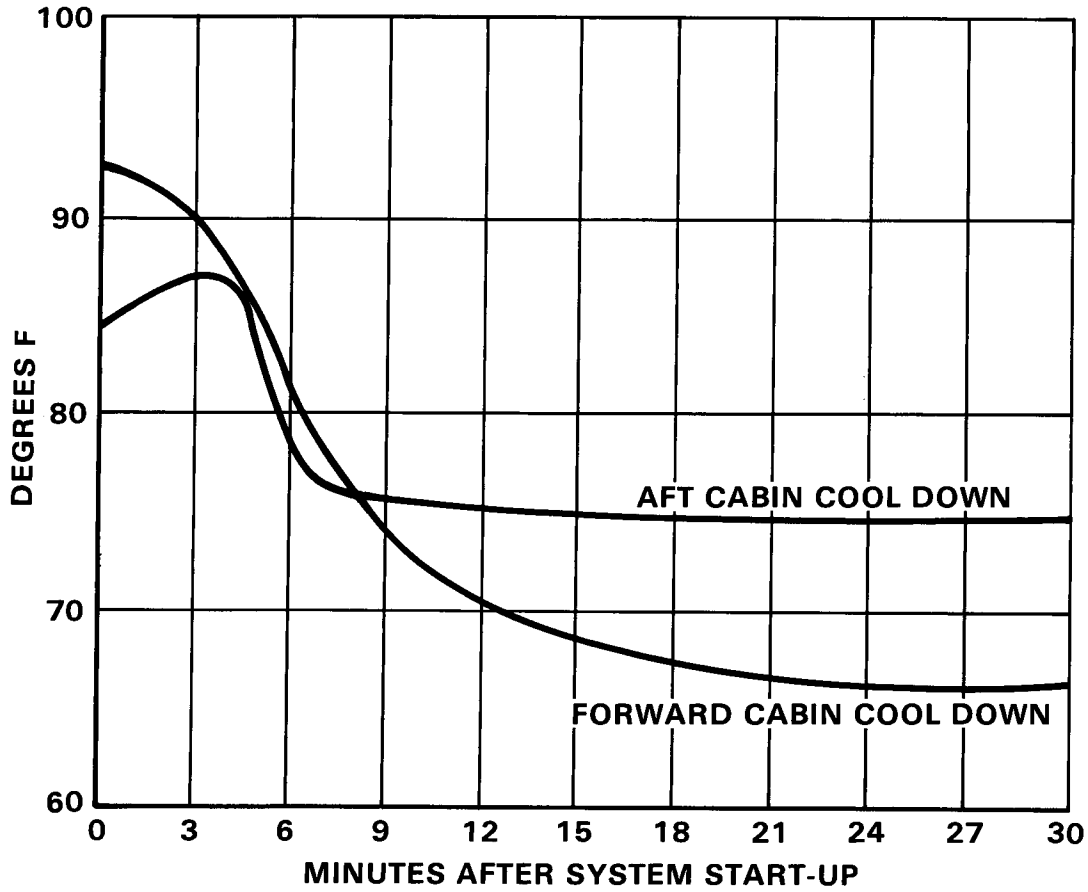

025262

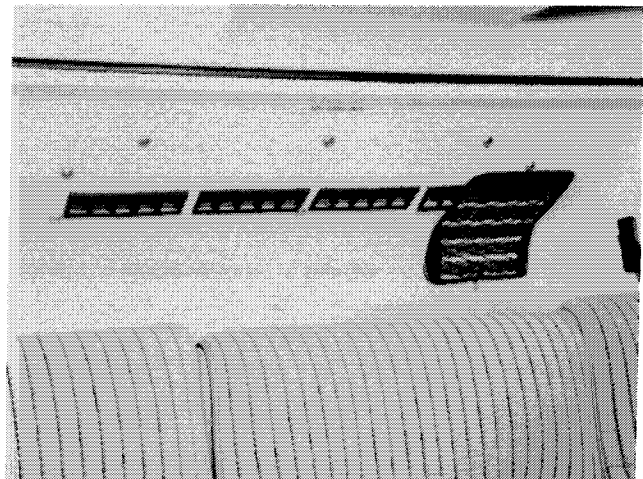

025259



THIS IS AN UNCONTROLLED DOCUMENT. THE DATA IS PRESENTED FOR GENERAL INFORMATION ONLY. SOME INFORMATION HAS BEEN SUPERCEDED SINCE ORIGINAL PUBLICATION. PLEASE REFER TO THE CURRENT PRODUCT SPECIFICATION BOOKLET FOR UP-TO-DATE STANDARD EQUIPMENT LIST & KIT WEIGHTS, PERFORMANCE, AND DIRECT OPERATING COST.

BELL 206B JETRANGER III

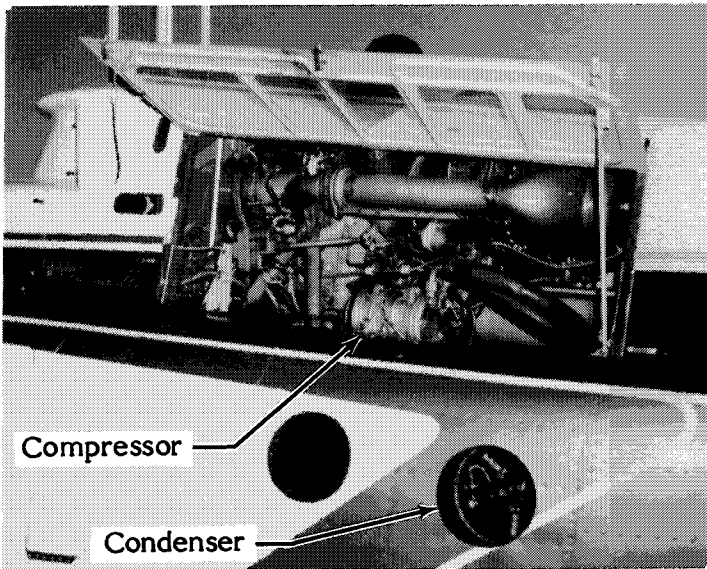
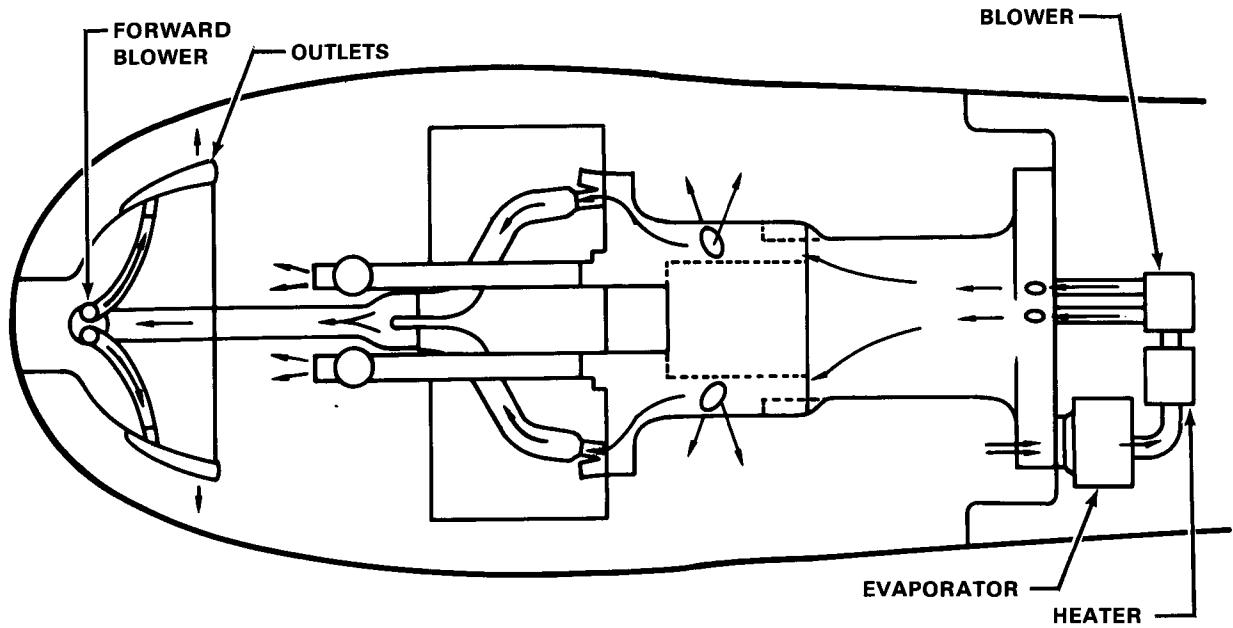

025254



BASIC PANEL

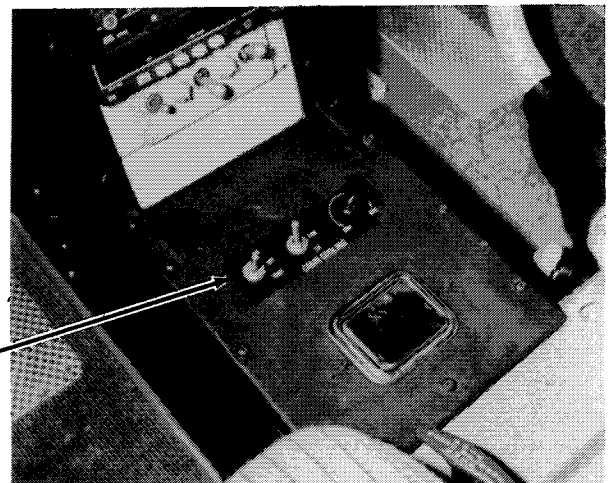

025263



THIS IS AN UNCONTROLLED DOCUMENT. THE DATA IS PRESENTED FOR GENERAL INFORMATION ONLY. SOME INFORMATION HAS BEEN SUPERCEDED SINCE ORIGINAL PUBLICATION. PLEASE REFER TO THE CURRENT PRODUCT SPECIFICATION BOOKLET FOR UP-TO-DATE STANDARD EQUIPMENT LIST & KIT WEIGHTS, PERFORMANCE, AND DIRECT OPERATING COST.

BELL 206B JETRANGER III

THE COMPLETE PARKER HANNIFIN ENVIRONMENTAL CONTROL SYSTEM

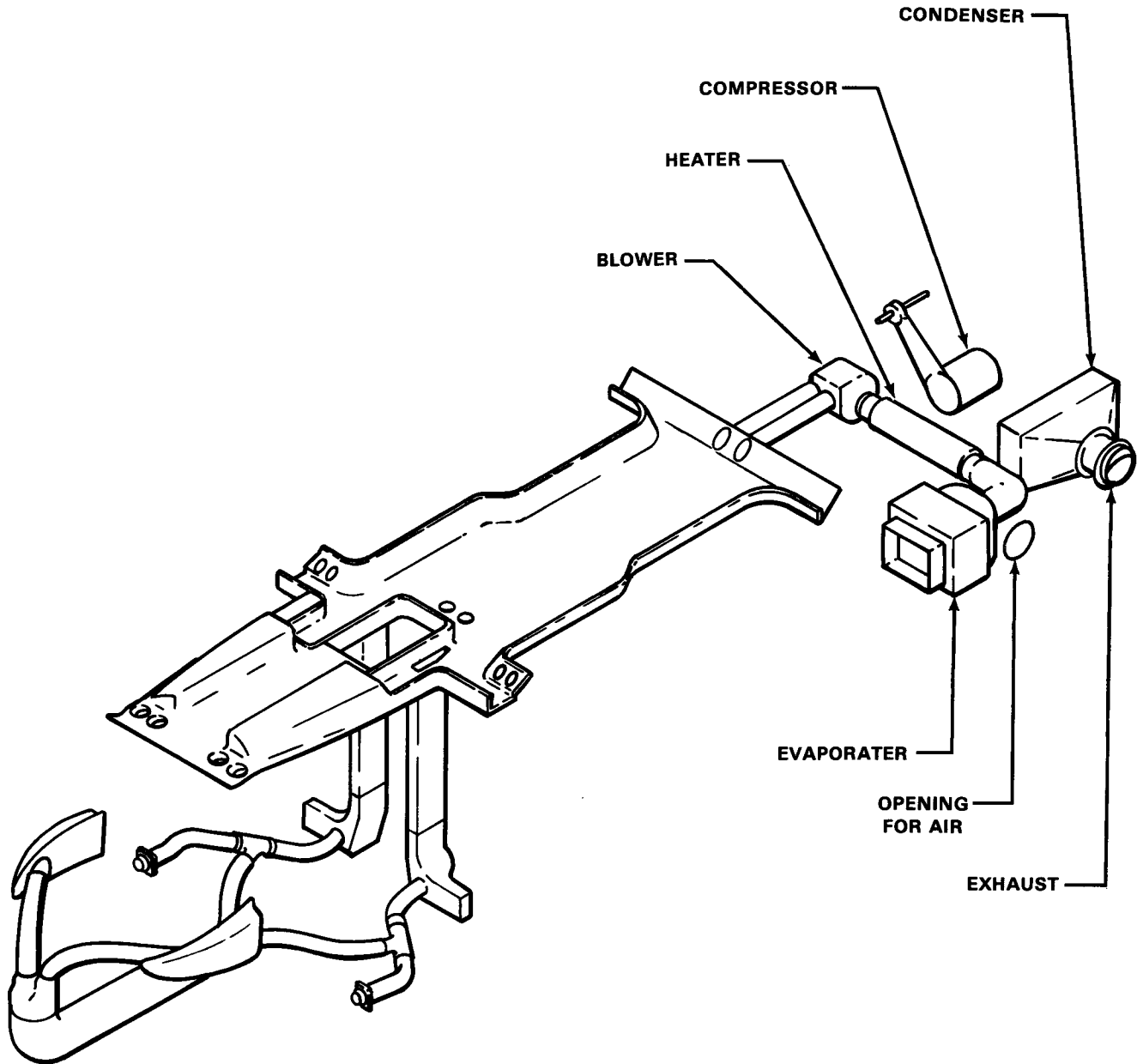

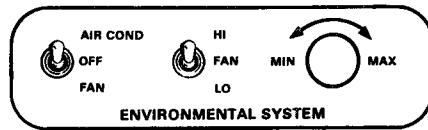

BASIC PANEL

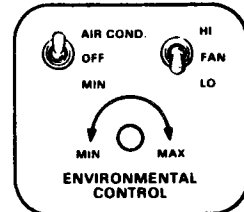

ALTERNATE PANEL

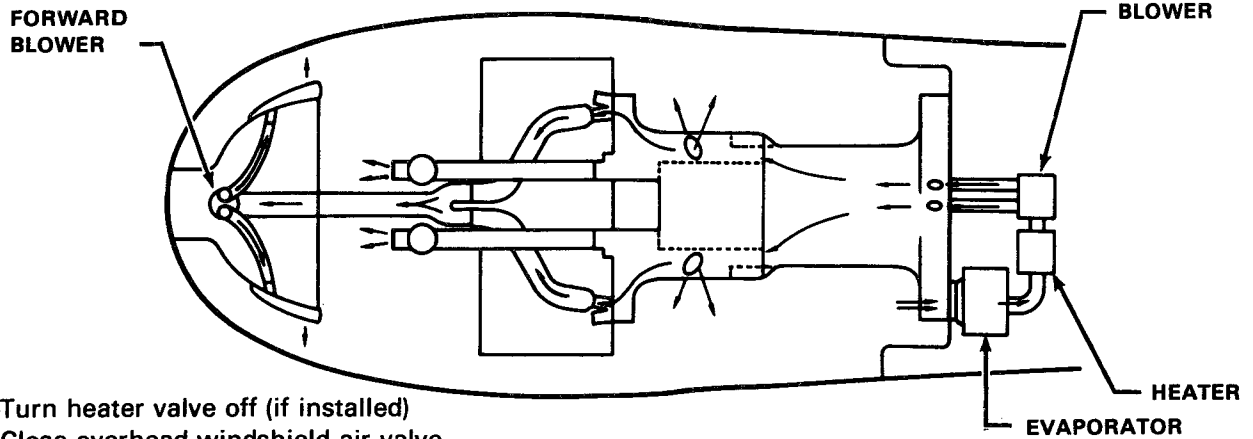

- Turn heater valve off (if installed)
- Close overhead windshield air valve
- Open overhead & instrument panel vents as desired
- Turn air cond — off — fan switch to air cond
- Turn hi — fan — low switch to hi or low as desired
- Set temperature control min — max to desired position

AIR CONDITIONER OPERATING INSTRUCTIONS AND DESCRIPTION

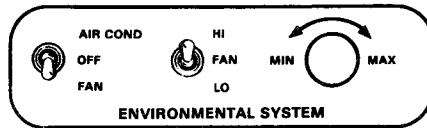

BASIC PANEL

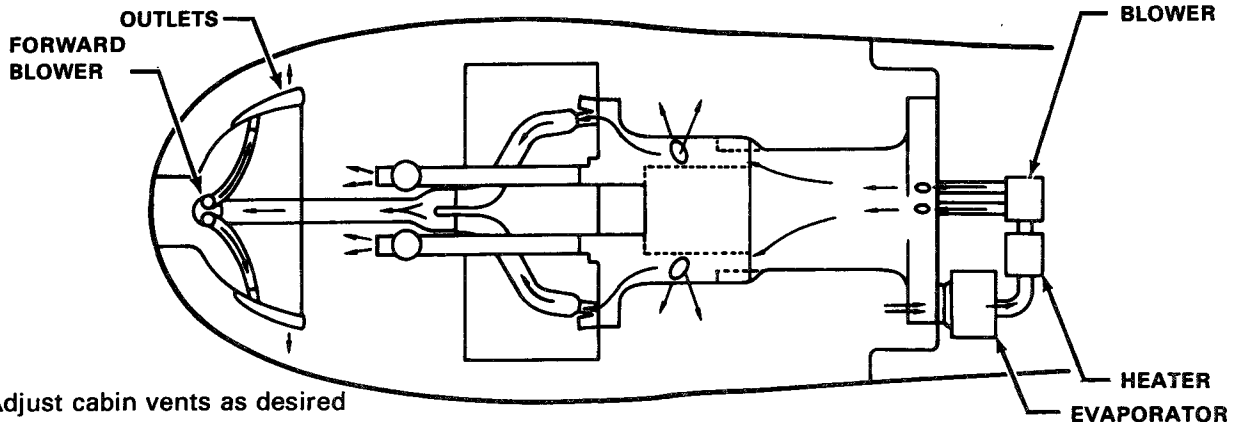
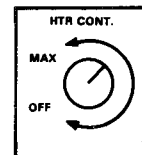

- Adjust cabin vents as desired
- Adjust heater control to desired comfort setting
- Turn air cond — off — fan switch to fan (if installed)
- Turn hi — fan — lo switch to hi or lo as desired (if installed)

CABIN HEATER OPERATING INSTRUCTIONS AND DESCRIPTION



THIS IS AN UNCONTROLLED DOCUMENT. THE DATA IS PRESENTED FOR GENERAL INFORMATION ONLY. SOME INFORMATION HAS BEEN SUPERCEDED SINCE ORIGINAL PUBLICATION. PLEASE REFER TO THE CURRENT PRODUCT SPECIFICATION BOOKLET FOR UP-TO-DATE STANDARD EQUIPMENT LIST & KIT WEIGHTS, PERFORMANCE, AND DIRECT OPERATING COST.

BELL 206B JETRANGER III

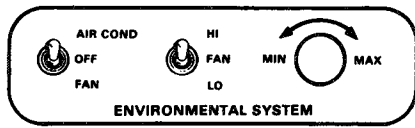

BASIC PANEL

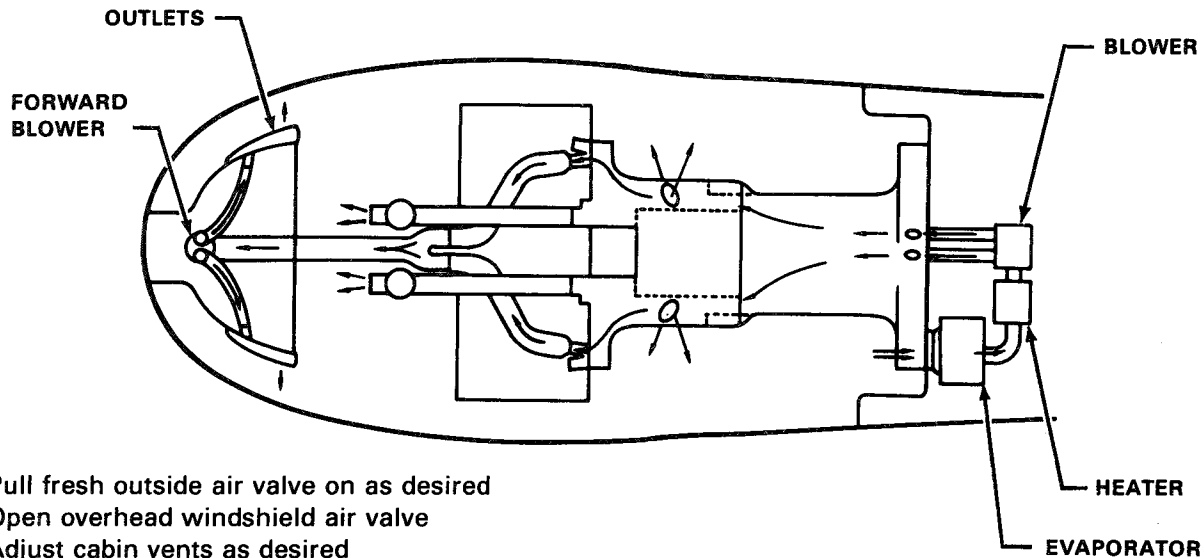
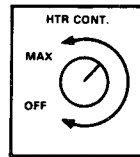

- Pull fresh outside air valve on as desired
- Open overhead windshield air valve
- Adjust cabin vents as desired
- Adjust heater control to desired setting
- Turn air cond — off — fan switch to air cond (if installed)
- Turn hi — fan — lo switch to hi or lo as desired (if installed)

CABIN DEFOGGING OPERATING INSTRUCTIONS AND DESCRIPTION

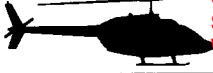

CARGO HOOK

BELL KIT NO. 206-706-335-005
PROVISIONS KIT
BELL KIT NO. 206-706-335-101
CARGO HOOK KIT

The purpose of the Cargo Hook kits is to provide a cargo hook capability for external loads up to 681 kilograms (1500 pounds). The hook has an electrical release with a mechanical back-up in case of power failure.

The two separate kits - the provisions kit and the cargo hook kit - allow the customer complete flexibility.

The separate provisions kit enables the fleet owner to prepare more than one of his JetRangers, at minimum cost, so that any one of them, so equipped, can be selected to undertake external cargo operations without delay. Once the

provisions are installed, the installation or removal of the U-frame and cargo hook can be done quickly and easily in the field.

The Cargo Hook Provisions Kit consists of the frame supports and associated structural additions, fittings for the electrical and mechanical release mechanisms, and the necessary installation hardware.

The electrical release is a switch on the pilot's cyclic stick just below the grip. The mechanical release is centrally located between the front seats. A circuit breaker on the overhead panel completes the kit.



294724



The Cargo Hook Kit consists of the U-frame and hook assembly.

The hook is suspended on a lateral pin in a U-frame with the hook opening to the right side. The frame, in turn, is suspended from three points, two forward and one rear. The U-frame is inserted in the rear support and pinned at the front two. The electric connection and the ball connector for the release systems are quick plug-ins.

A bungee shock cord on the hook provides automatic stowage holding the hook to the rear when it is not in use. A clamp is provided so that the loose end of the ball connector can be stowed when the hook is removed from the helicopter.

A swivel link is not supplied, but is recommended to allow the load to assume a natural stabilized position with minimum oscillation in flight.

The weight increase with only the provisions kit installed is 1.7 kilograms (3.9 pounds). With the complete installation it is 10.4 kilograms (23 pounds).

Flight Procedures are contained in the Flight Manual Supplement. Maximum gross weight is approved to 1519.5 kilograms (3350 pounds) including external load.

Maximum external cargo load is 681 kilograms (1500 pounds).

Speed is limited to 169 km/h (91 mph-78 kn) for gross weights above 1360.8 kilograms (3000 pounds).

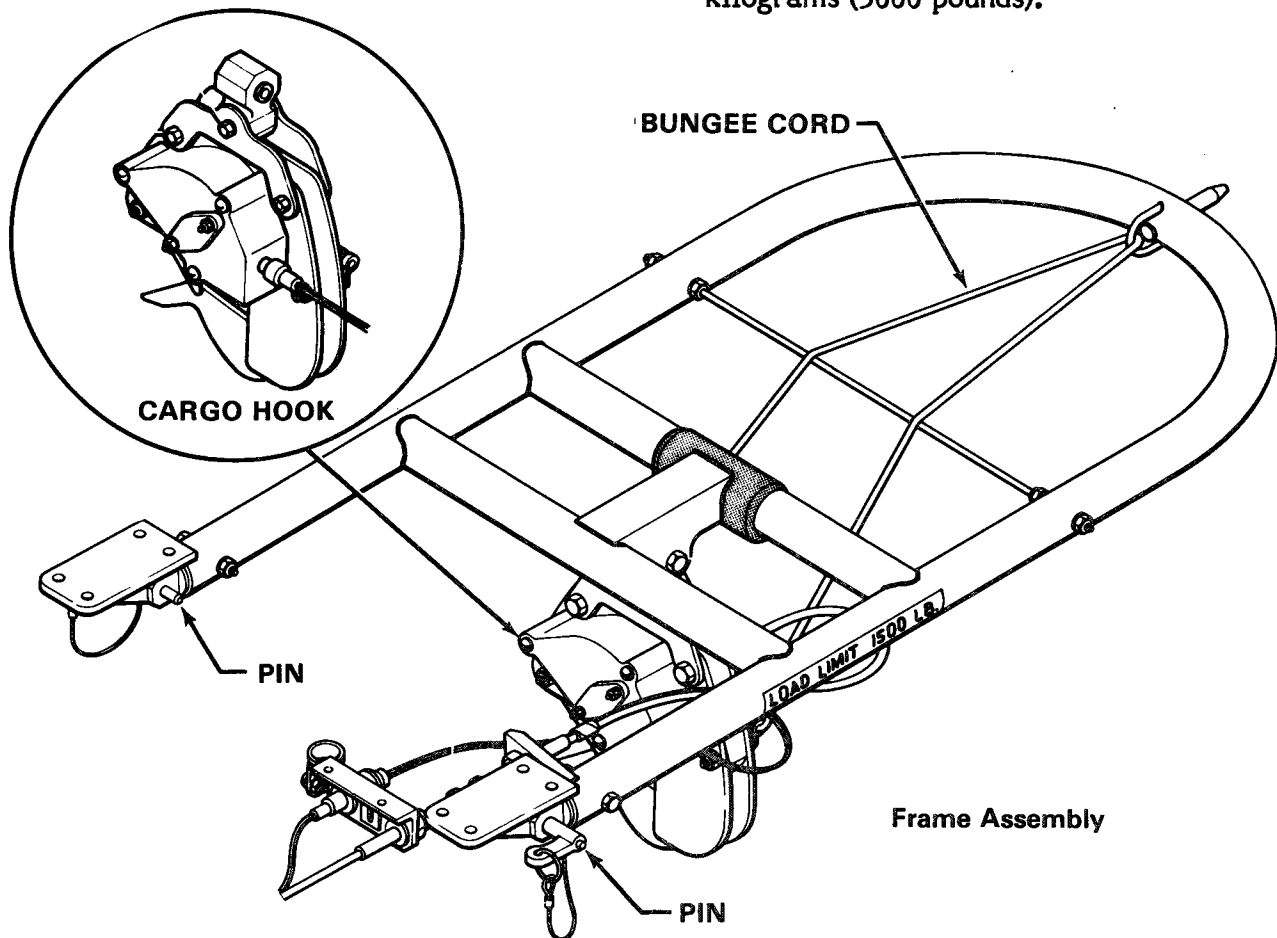



THIS IS AN UNCONTROLLED DOCUMENT. THE DATA IS PRESENTED FOR GENERAL INFORMATION ONLY. SOME INFORMATION HAS BEEN SUPERCEDED SINCE ORIGINAL PUBLICATION. PLEASE REFER TO THE CURRENT PRODUCT SPECIFICATION BOOKLET FOR UP-TO-DATE STANDARD EQUIPMENT LIST & KIT WEIGHTS, PERFORMANCE, AND DIRECT OPERATING COST.

BELL 206B
JETRANGER III

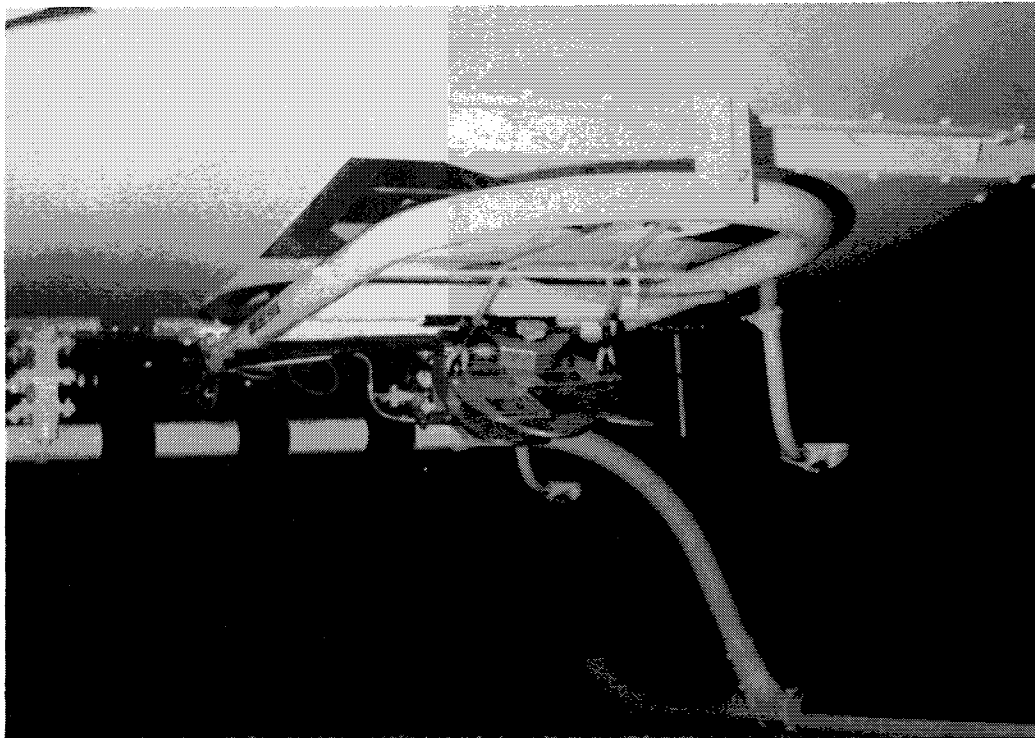

Cargo hook and provisions

008982

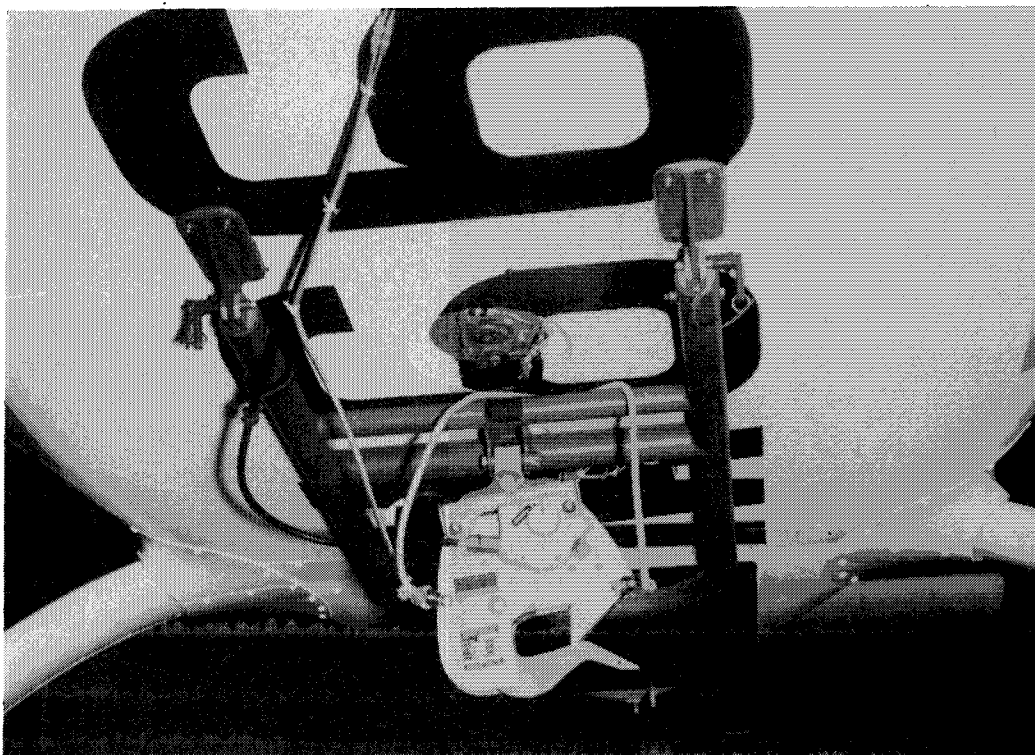

Cargo hook and provisions

286085



THIS IS AN UNCONTROLLED DOCUMENT. THE DATA IS PRESENTED FOR GENERAL INFORMATION ONLY. SOME INFORMATION HAS BEEN SUPERCEDED SINCE ORIGINAL PUBLICATION. PLEASE REFER TO THE CURRENT PRODUCT SPECIFICATION BOOKLET FOR UP-TO-DATE STANDARD EQUIPMENT LIST & KIT WEIGHTS, PERFORMANCE, AND DIRECT OPERATING COST.

BELL 206B JETRANGER III



Support Provisions

276083

Installation and Maintenance Instructions are contained in the Bell Service Instruction 206-94.

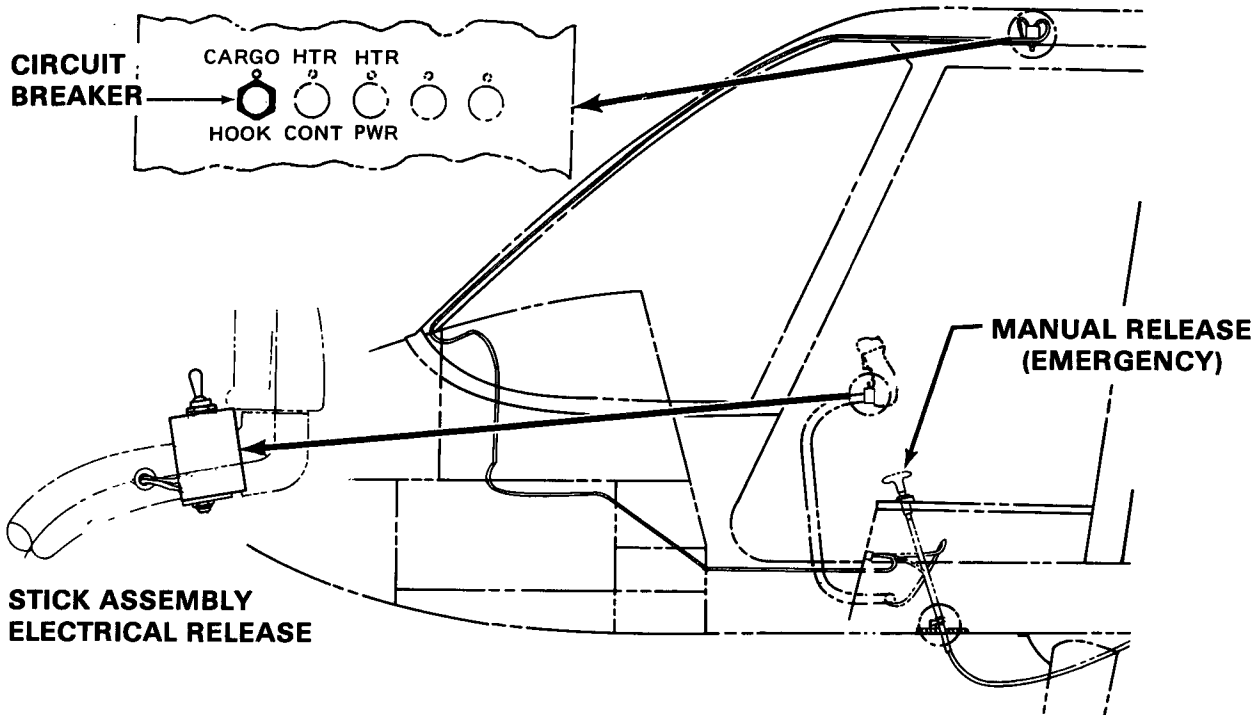



LITTERS

BELL KIT NO. 206-706-314-103
PROVISIONS KIT
BELL KIT NO. 206-706-324-001
LITTER KIT

The purpose of the Litter kits is to provide the capability of transporting one or two litter patients internally. To accomplish this, a fuselage modification is required, part of which includes a clam shell door arrangement. Installing a second set of hinges on the rear door and making the center door post removable permits unobstructed access to the whole left side of the cabin. Not only does this make the loading and unloading of the litter patients as quick and easy as possible, it allows the transportation of a much wider range of internal cargo items.

The two separate kits - the provisions kit and the litter kit - allow the customer complete flexibility at minimum cost.

The provisions kit installed in several units of a fleet allows any one helicopter to take over a medical "stand-by" role without having to stock unwanted numbers of litters. Conversely spare litters can be strategically placed, at hospitals for example, for ready access to the one unit.

Both litters can be stowed in the baggage compartment - readily available during other missions.

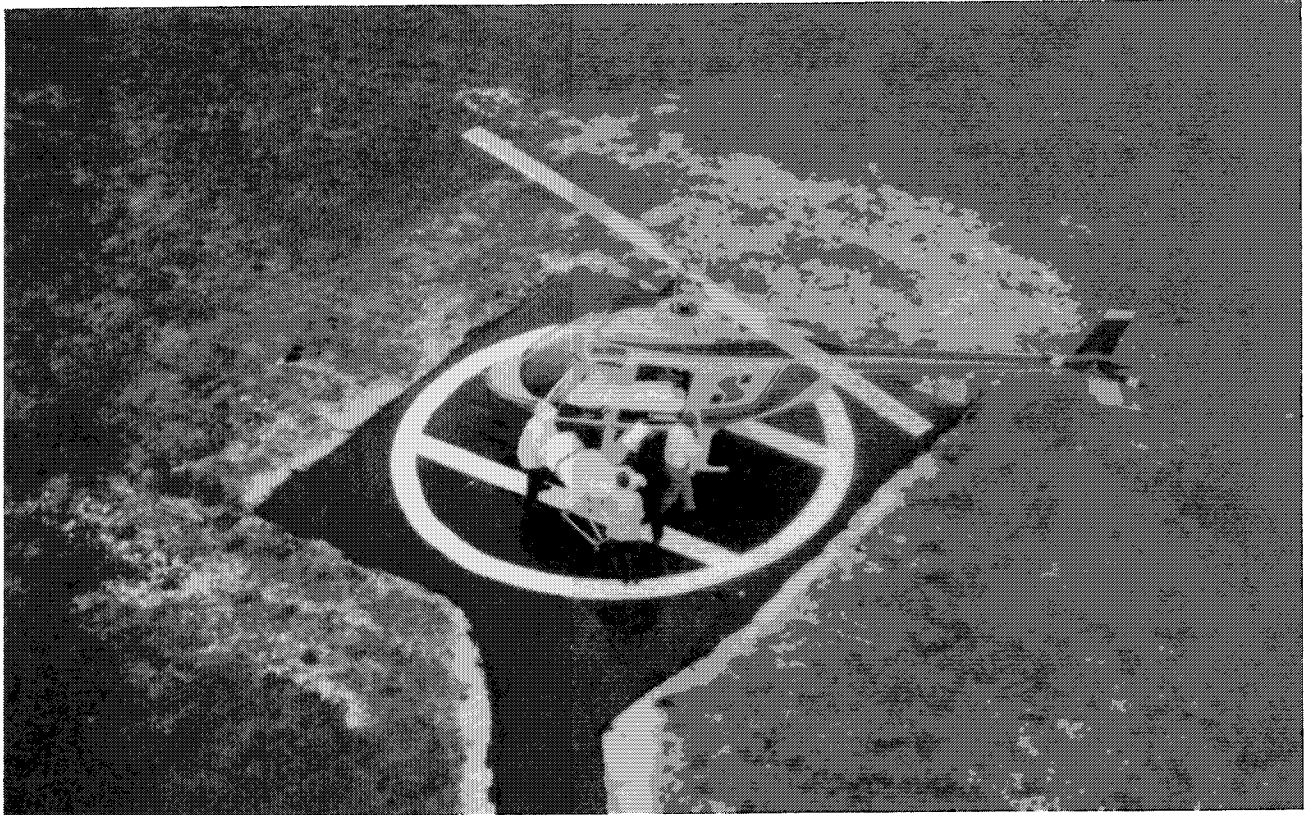

021959



300807

The Litter Provisions kit, 206-706-314-103, consists of the materials needed to convert the standard airframe into the ambulance configuration. Modifications affect the left front seat, upholstery, bulkhead and frame, particularly the left rear door and the center post. It modifies the fuselage to take the two litters, one above the other, fore and aft on the left side of the helicopter. Spring-loaded clips on the airframe hold the head of each litter to prevent fore and aft movement. The left rear door is hinged at the rear edge. The center post is modified so that it is removable. A handle on the forward face of the post releases it from the fuselage. The post and the rear door then swing back as one unit. A tape tieback is provided to hold it in the full open position. With the rear door open in this manner,

and the front door held at its fullest extent forward by means of its tape tieback, full access is gained.

This modification does not affect the conventional five-place role. The left rear door continues to open normally, using hinges on the forward edge. With the modification, however, the standard five-place configuration can be converted immediately to the ambulance configuration, on site.

The litter kit, 206-706-324-001, consists of two folding aluminum litters, each with a pair of patient restraining straps. Each patient is loaded feet first. The spring-loaded clips on the airframe hold the head of each litter, and when the center post is securely closed, restraint of the litters is complete.



Although similar in appearance, the JetRanger litters and the LongRanger litters are not interchangeable.

There are several advantages to the litter configuration:

- because the two litters can be carried in the baggage compartment, taking up little of the space and weight, there is instant availability during virtually any other mission;
- the modification does not interfere with any other configuration requirement;
- the patient(s) are inside, quiet and warm;
- the medical attendant can function while comfortably seated and secured;
- the medical attendant has sufficient headroom over each patient to allow the application of en route life-saving measures;
- there are no flight restrictions;
- if only one litter is required, it can be installed on the upper rack without having to stow any of the seats;
 - there is room for considerable, easy to get at, medical stores; and
- in the cargo role, the wider door opening allows easier loading of bulky items.

In the continuing rescue role, one or two litters can be left in place. The baggage compartment, the shelf behind the rear seat and the floor space underneath the litters can be used for boxes of medical stores. The litters can carry blankets, etc., and the seatback in front of the medical attendant can carry equipment.

The weight increase with only the provisions kit installed is 7.7 kilograms (17 pounds). The litters each add 7.2 kilograms (16 pounds), for a total weight of 22.1 kilograms (49 pounds).

Flight Procedures. There are no flight restrictions.

The fixed floats, the Chadwick long-range tanks, and the maintenance step kit (if installed), each interfere with the opening of the rear door on the aft hinges. This can be overcome by removal of the rear door for loading and for the duration of the operation, if convenient, and if weather permits.

Installation and Maintenance Instructions are contained in the Bell Service Instruction 206-68.



THIS IS AN UNCONTROLLED DOCUMENT. THE DATA IS PRESENTED FOR GENERAL INFORMATION ONLY. SOME INFORMATION HAS BEEN SUPERCEDED SINCE ORIGINAL PUBLICATION. PLEASE REFER TO THE CURRENT PRODUCT SPECIFICATION BOOKLET FOR UP-TO-DATE STANDARD EQUIPMENT LIST & KIT WEIGHTS, PERFORMANCE, AND DIRECT OPERATING COST.

BELL 206B
JETRANGER III

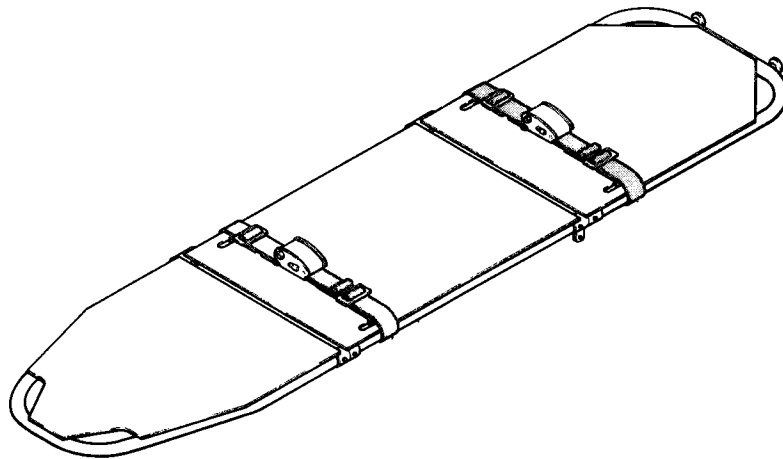



THIS IS AN UNCONTROLLED DOCUMENT. THE DATA IS PRESENTED FOR GENERAL INFORMATION ONLY. SOME INFORMATION HAS BEEN SUPERCEDED SINCE ORIGINAL PUBLICATION. PLEASE REFER TO THE CURRENT PRODUCT SPECIFICATION BOOKLET FOR UP-TO-DATE STANDARD EQUIPMENT LIST & KIT WEIGHTS, PERFORMANCE, AND DIRECT OPERATING COST.

BELL 206B JETRANGER III

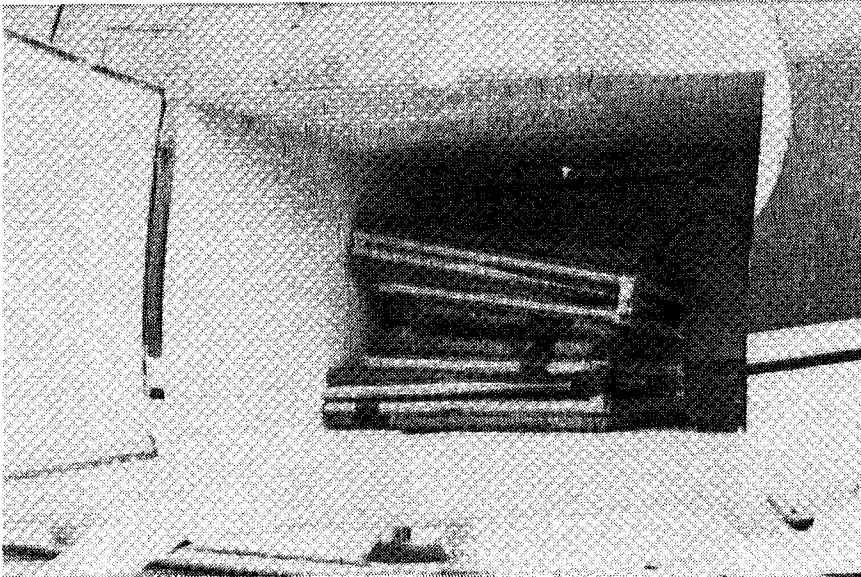

275318



275318



275318



THIS IS AN UNCONTROLLED DOCUMENT. THE DATA IS PRESENTED FOR GENERAL INFORMATION ONLY. SOME INFORMATION HAS BEEN SUPERCEDED SINCE ORIGINAL PUBLICATION. PLEASE REFER TO THE CURRENT PRODUCT SPECIFICATION BOOKLET FOR UP-TO-DATE STANDARD EQUIPMENT LIST & KIT WEIGHTS, PERFORMANCE, AND DIRECT OPERATING COST.

BELL 206B
JETRANGER III



005560



005567



006061



THIS IS AN UNCONTROLLED DOCUMENT. THE DATA IS PRESENTED FOR GENERAL INFORMATION ONLY. SOME INFORMATION HAS BEEN SUPERCEDED SINCE ORIGINAL PUBLICATION. PLEASE REFER TO THE CURRENT PRODUCT SPECIFICATION BOOKLET FOR UP-TO-DATE STANDARD EQUIPMENT LIST & KIT WEIGHTS, PERFORMANCE, AND DIRECT OPERATING COST.

BELL 206B JETRANGER III



286619

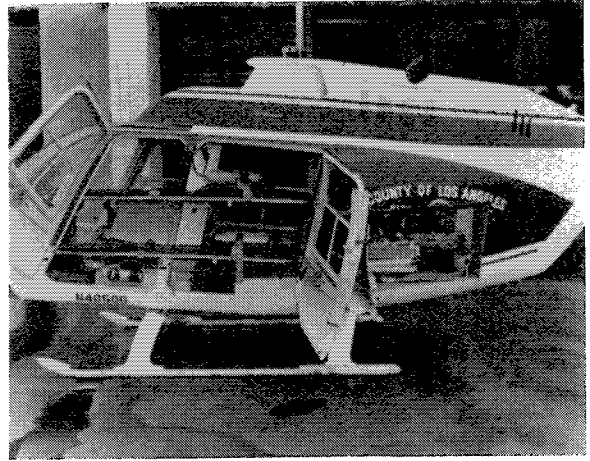

286615

"First Response" and Medical Evacuation

Pictures Courtesy County of
Los Angeles Fire Department and
Surf Life Saving Association of
Australia

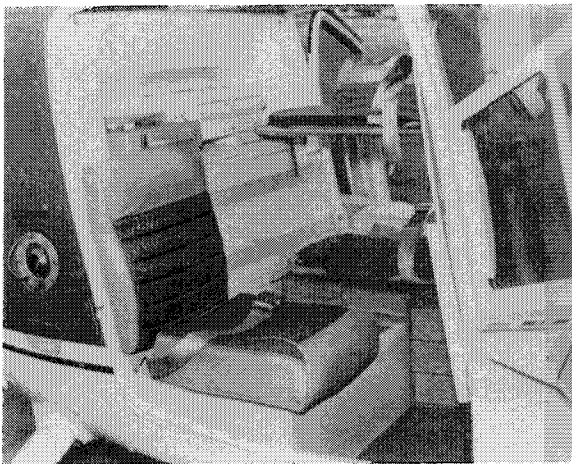

286620

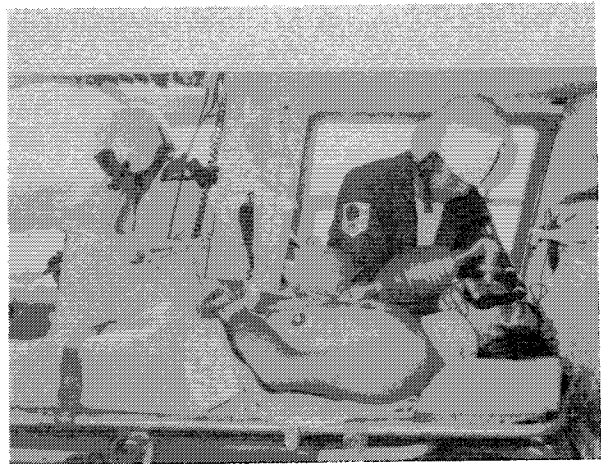



THIS IS AN UNCONTROLLED DOCUMENT. THE DATA IS PRESENTED FOR GENERAL INFORMATION ONLY. SOME INFORMATION HAS BEEN SUPERCEDED SINCE ORIGINAL PUBLICATION. PLEASE REFER TO THE CURRENT PRODUCT SPECIFICATION BOOKLET FOR UP-TO-DATE STANDARD EQUIPMENT LIST & KIT WEIGHTS, PERFORMANCE, AND DIRECT OPERATING COST.

BELL 206B
JETRANGER III



HOIST

BELL KIT NO. 206-706-126-003
PROVISIONS KIT
BELL KIT NO. 206-706-126-101
HOIST KIT

The purpose of the Hoist kits is to permit delivery or pick up of personnel or cargo from areas not suitable for a helicopter landing.

The hoist has been FAA approved to carry the full 136 kilogram (300 pound) load through three consecutive cycles (full down and full up), resting 30 seconds at the end of each run. The three cycles can be repeated at 40-minute intervals. If the load or cable length is reduced, then the number of cycles can

be increased. For example, with a 91 kilogram (200 pound) load, and a 15 meter (50 foot) cable length, the hoist is capable of continuous operation.

The two separate kits - the provisions kit and the hoist kit - allow the customer complete flexibility.

The Hoist Provisions Kit, 206-706-126-003, consists of the pilot cyclic grip assembly, master control panel, structural provisions, hoist supports, guard



01786

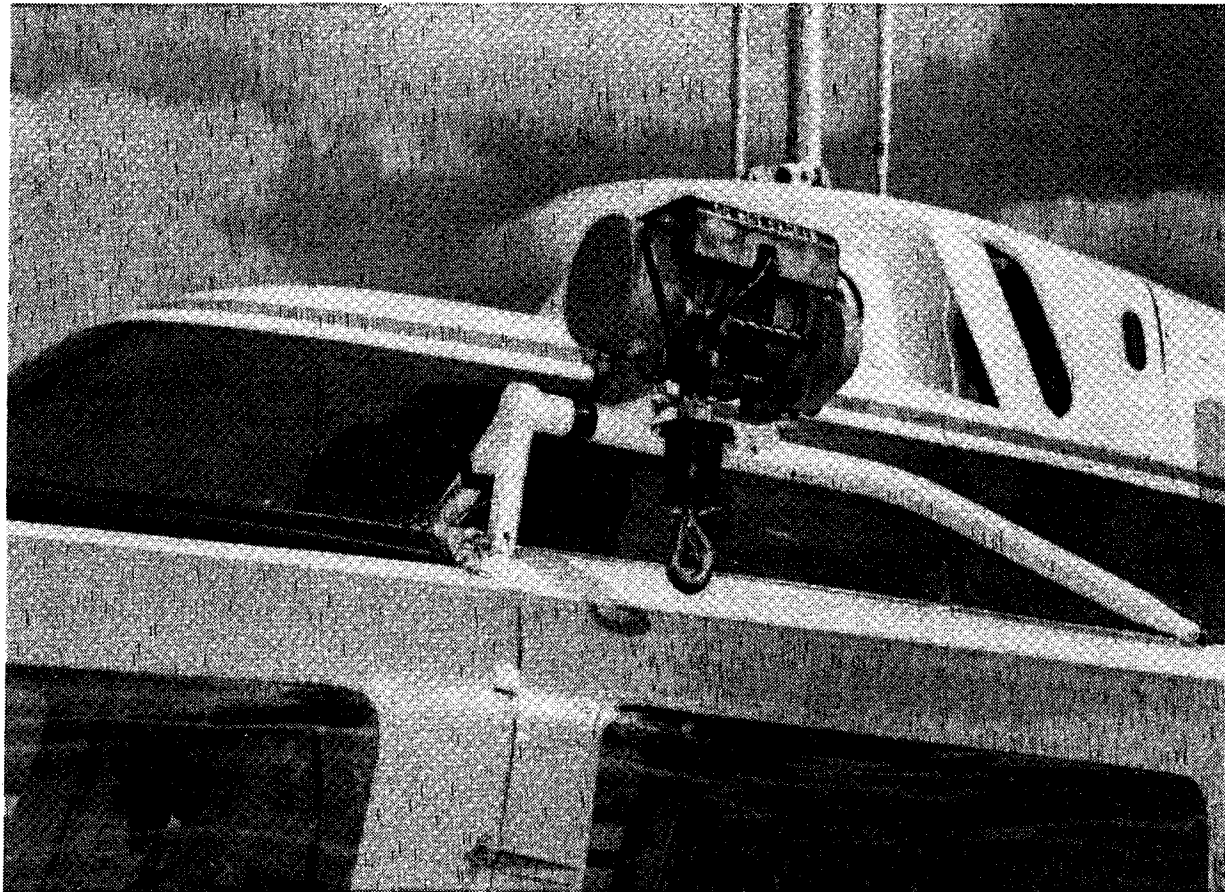

008556

assemblies for the skid gear, and the necessary hardware and electrical components.

Two overhead circuit breakers are provided: one for hoist power, the other for cable-cut power.

The Hoist Kit, 206-706-126-101, consists of the hoist motor and winch assembly, mounting frame, crewman pendant control, guards for the fuselage and the necessary hardware and electrical components to complete the installation.

The hoist is externally mounted above the left rear door. It is fastened to the fuselage attachment points by three easily inserted pins, and has quick "plug-in" electrical attachments.

During the operation the hoist cable travels between fuselage and skid. To help prevent wear, different guards are provided. The kit includes one guard that fits the skids of either the standard or the high skid landing gear, and one that fits on the fuselage for either configuration, just below the left doors.

The hoist, built by Breeze Corporation, Inc., has an approved capacity of 136 kilograms (300 pounds), a cable length of 33.5 meters (110 usable feet) and a rate of 15.2 meters (50 feet) a minute. The last 9 meters (30 feet) of the cable are painted red as a caution to the operator.

The pilot can control the hoist operation from a spring-loaded switch on the cyclic stick grip. The hoist master-panel mounted at the left of the instrument panel provides him with:

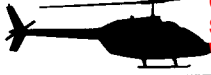

1. A power switch which energizes the system and also enables control to be switched from his cyclic stick to the crewman's pendant;
2. A "cable-cut" switch, protected by a spring-loaded guard cover which operates an electric "guillotine" to shear the cable in the event it becomes fouled.

The grip with the hoist control switch can be installed on the copilot's stick. Usually, however, it is put on the pilot's stick.

The crewman's pendant is a pistol-grip control which is connected to the plug on the vertical control tunnel by a length of coiled cable. The up/off/down switch on the grip is spring-loaded to the off position.

The transmission and motor assemblies are sealed units and require no lubrication or adjustments.

A fail-safe electromechanical brake will not permit backing off under any load within the capacity of the hoist. It operates automatically when the hoist is stopped from motion in either direction, even when power failure occurs. The brake assembly requires no maintenance.

The free-swiveling hook is equipped with a safety keeper, and an energy-absorbing rubber bumper.

A limit switch prevents run-out beyond the last three windings of the cable.

Another limit switch stops the motor, on reel-in, when the bumper ring contacts the hook assembly.

The spin-resistant stainless steel cable is 0.32 centimeter (1/8 inch) in diameter, and is designed to an 862 kilogram (1900 pound) breaking strain.

The weight increase with only the provisions kit installed is 4.5 kilograms (10 pounds). With the complete installation it is 20 kilograms (44 pounds).

Flight procedures are contained in the Flight Manual Supplement.

- If fuselage-mounted steps are in use, the left rear one must be removed.
- Since the hoist load comes up inside the skid, the high-skid gear is recommended, particularly for personnel hoisting. This provides more room and makes it easier to climb aboard the helicopter.
- Gloves and helmet are recommended for all personnel, particularly those being hoisted.
- The pilot should test every load by lifting it slightly off the surface with collective pitch. This provides a sense of control feel before operating the hoist motor.
- The object being hoisted must be completely in the cabin before forward flight is established.



THIS IS AN UNCONTROLLED DOCUMENT. THE DATA IS PRESENTED FOR GENERAL INFORMATION ONLY. SOME INFORMATION HAS BEEN SUPERCEDED SINCE ORIGINAL PUBLICATION. PLEASE REFER TO THE CURRENT PRODUCT SPECIFICATION BOOKLET FOR UP-TO-DATE STANDARD EQUIPMENT LIST & KIT WEIGHTS, PERFORMANCE, AND DIRECT OPERATING COST.

**BELL 206B
JETRANGER III**

- The left rear door is removed for the duration of the hoisting operation.
- If a flat object is being hoisted from a calm water surface, break the surface tension as the hoist commences.

The Hoist Kit is not compatible with the Emergency Floats unless the Hoist Cable Guard Kit, 206-706-214-101, is installed.

It is not compatible with Fixed Floats or the Chadwick Auxiliary Fuel System (C22) because of insufficient clearance.

Installation and Maintenance Instructions are contained in the Bell Service Instruction 206-64.

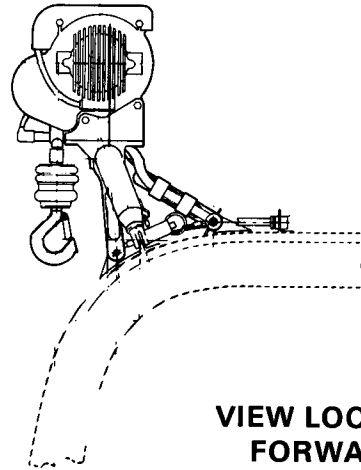

VIEW LOOKING FORWARD

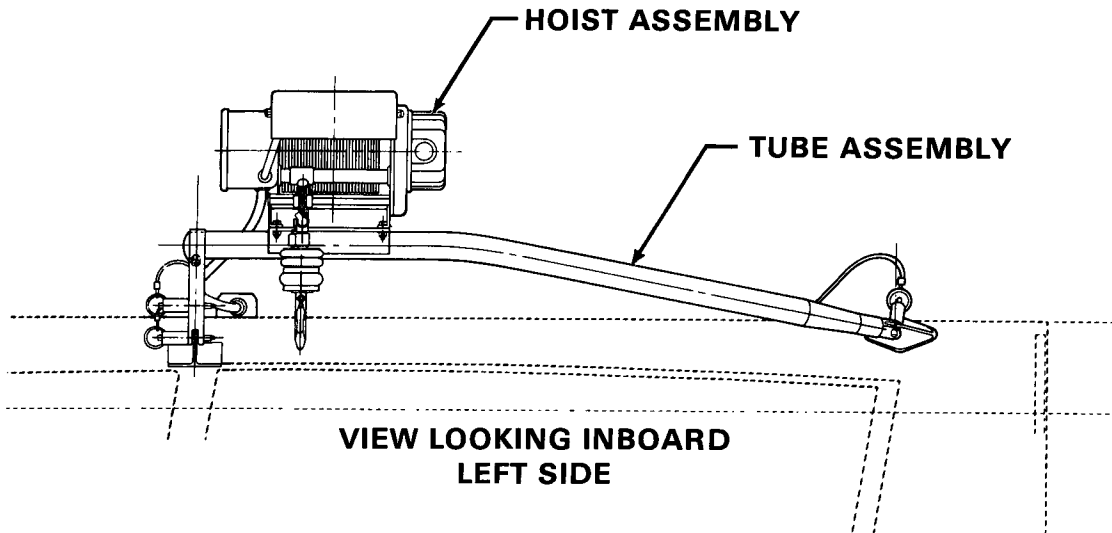

VIEW LOOKING INBOARD LEFT SIDE



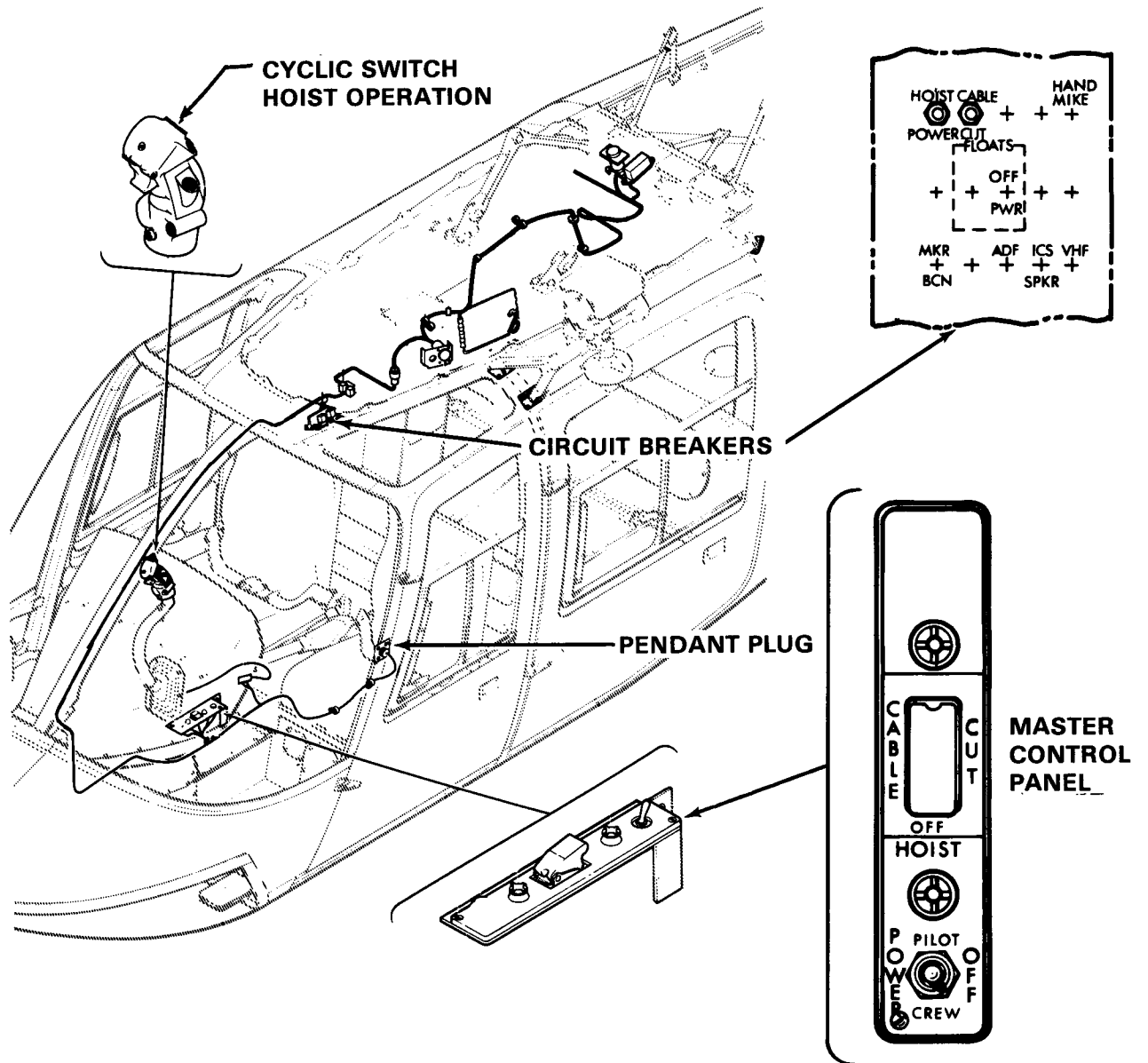

Hoist Provisions Kit



THIS IS AN UNCONTROLLED DOCUMENT. THE DATA IS PRESENTED FOR GENERAL INFORMATION ONLY. SOME INFORMATION HAS BEEN SUPERCEDED SINCE ORIGINAL PUBLICATION. PLEASE REFER TO THE CURRENT PRODUCT SPECIFICATION BOOKLET FOR UP-TO-DATE STANDARD EQUIPMENT LIST & KIT WEIGHTS, PERFORMANCE, AND DIRECT OPERATING COST.

**BELL 206B
JETRANGER III**

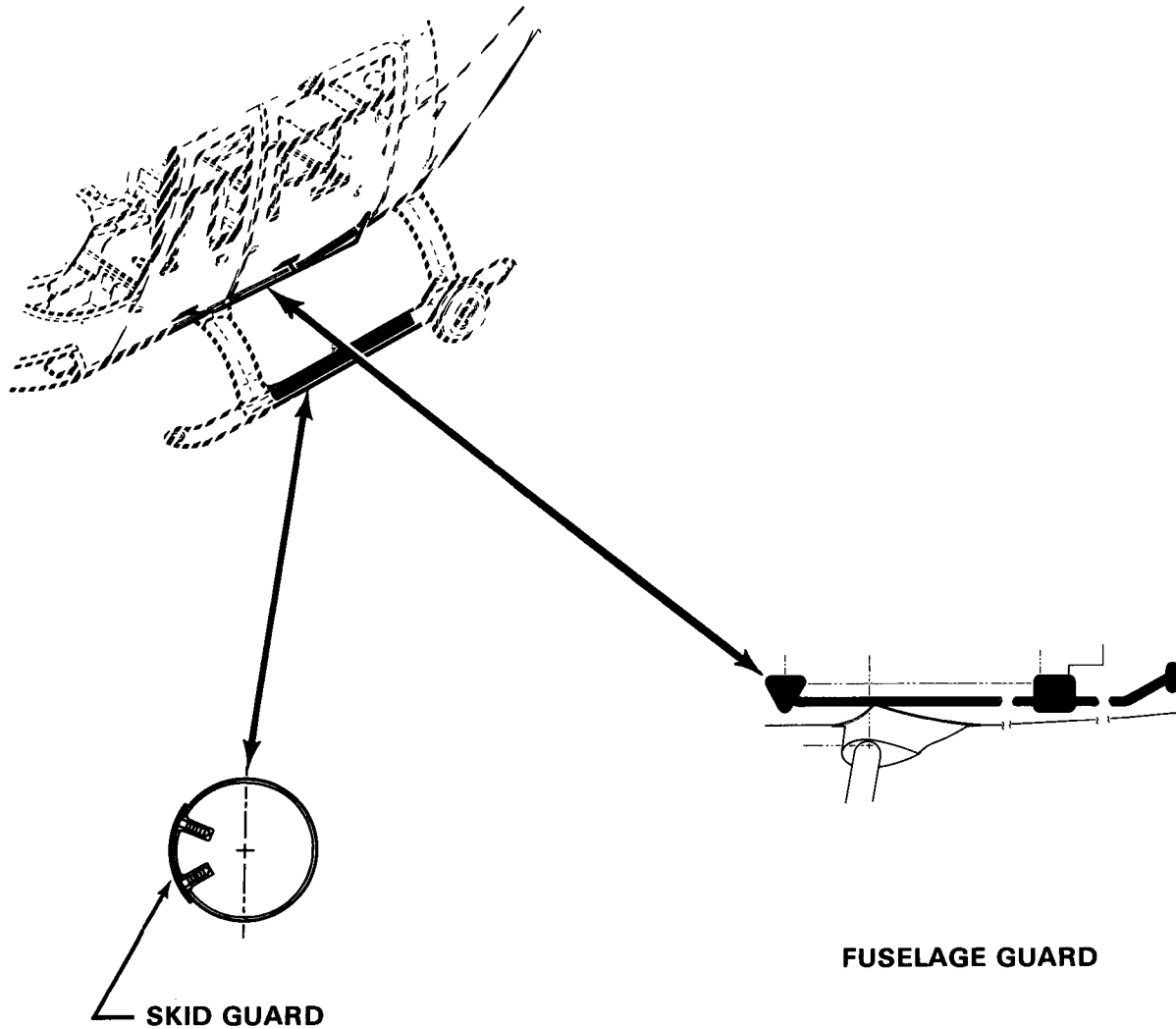

Step Modification and Guard Installation



HOIST CABLE GUARD

BELL KIT NO. 206-706-214-101

The purpose of the Hoist Cable Guard Kit is to provide protection for the stowed Emergency Floats so that the Hoist may be used.

The kit consists of hoops for the floats on the left side, a teflon coated guard and a fuselage-mounted step for the left front which replaces the full length skid-mounted step.

The weight increase with the Hoist Cable Guard kit installed is minus 0.5 kilograms (1 pound).

Flight procedures are contained in Flight Manual Supplements for the Hoist and the Emergency Floats.

Installation and Maintenance Instructions are contained in Bell Service Instruction 206-119.



THIS IS AN UNCONTROLLED DOCUMENT. THE DATA IS PRESENTED FOR GENERAL INFORMATION ONLY. SOME INFORMATION HAS BEEN SUPERCEDED SINCE ORIGINAL PUBLICATION. PLEASE REFER TO THE CURRENT PRODUCT SPECIFICATION BOOKLET FOR UP-TO-DATE STANDARD EQUIPMENT LIST & KIT WEIGHTS, PERFORMANCE, AND DIRECT OPERATING COST.

**BELL 206B
JETRANGER III**

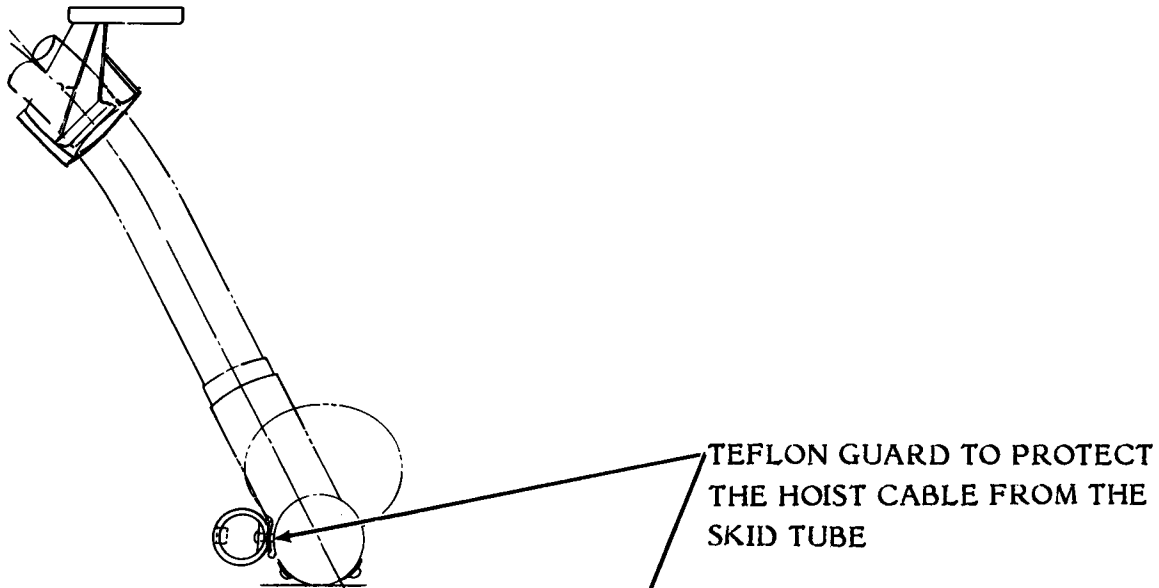

OVERHEAD VIEW

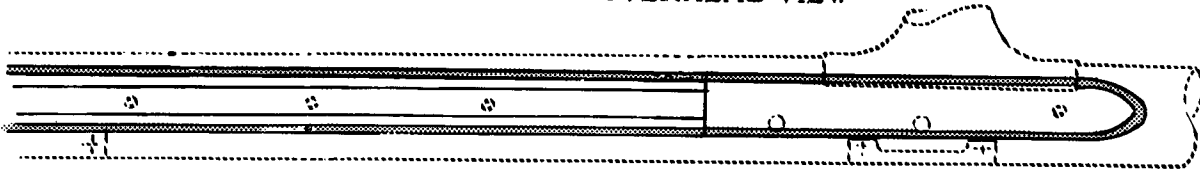

SIDE VIEW

RESTRAINING RUBBER HOOPS
THAT KEEP THE INFLATED
FLOAT RIGIDLY IN PLACE

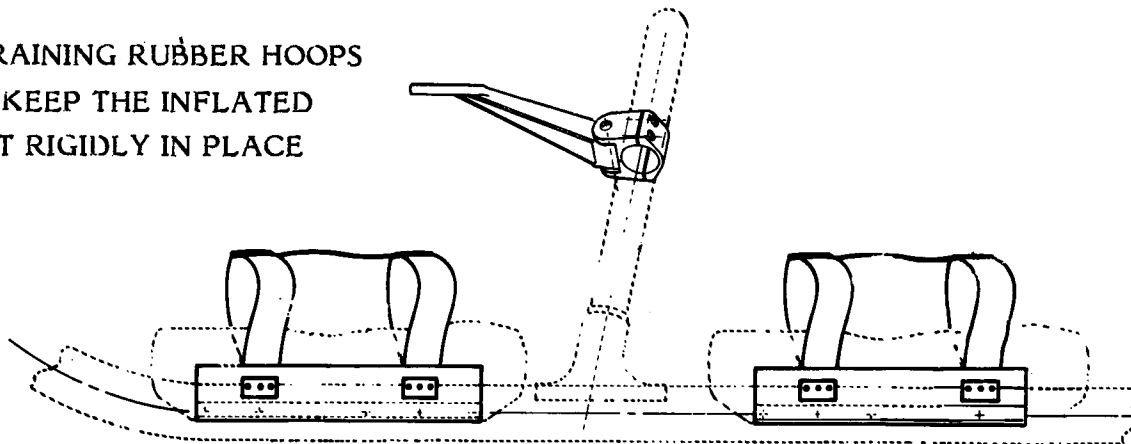

HOOPS ARE PACKED INSIDE
FLOAT COVERS WHEN STOWED



MAINTENANCE STEP

BELL KIT NO. 206-706-123-001

The purpose of the Maintenance Step kit is to provide a step for access to the engine and transmission area on the left side of the fuselage below the standard kick-in step.

The kit consists of one step and the attaching hardware.

The weight increase with the Maintenance Step kit installed is 1 kilogram (2 pounds).

Installation and Maintenance Instructions are contained in the Bell Service Instruction 206-54.

Installation of the step on an aircraft fitted for litters prevents full opening of the left rear door on its aft hinges. The door can be removed for loading and, if conditions are suitable, left off for the duration of the operation.

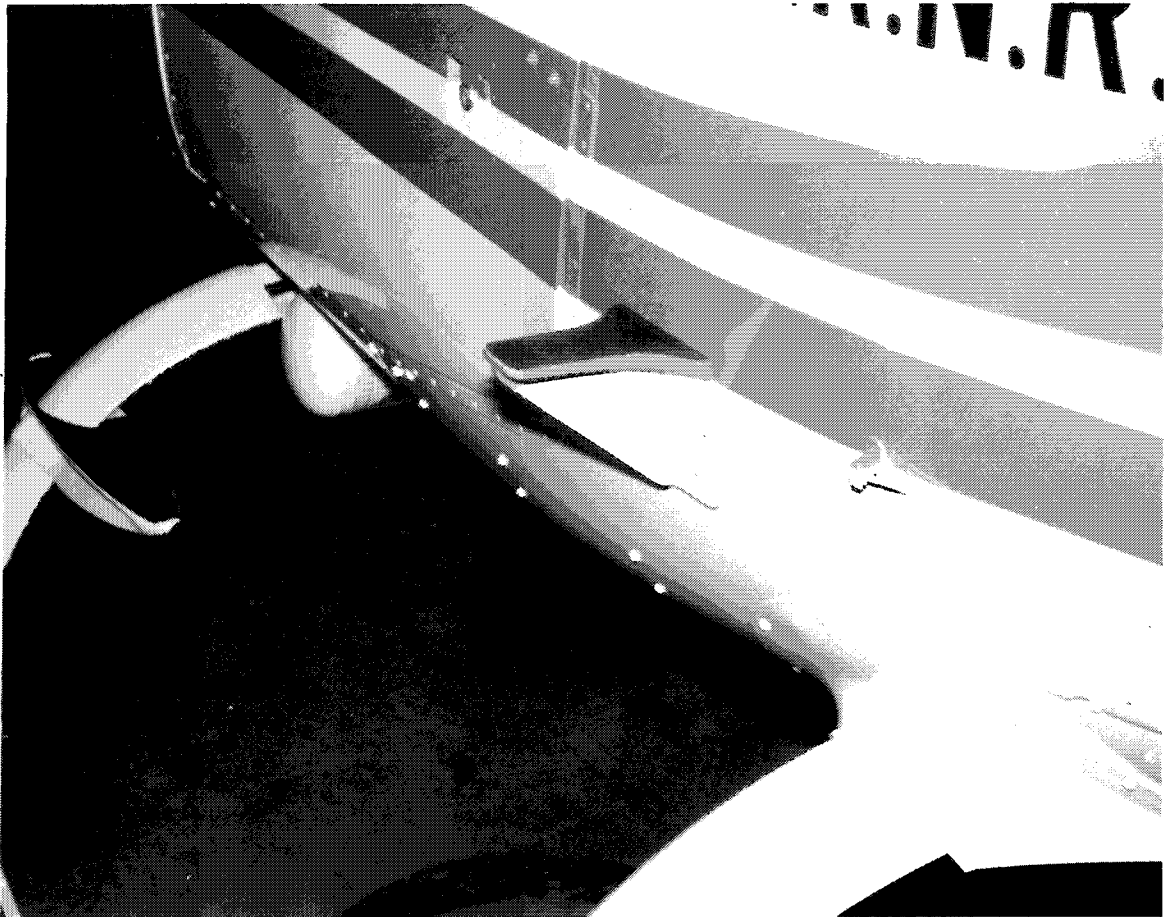

025278



THIS IS AN UNCONTROLLED DOCUMENT. THE DATA IS PRESENTED FOR GENERAL INFORMATION ONLY. SOME INFORMATION HAS BEEN SUPERCEDED SINCE ORIGINAL PUBLICATION. PLEASE REFER TO THE CURRENT PRODUCT SPECIFICATION BOOKLET FOR UP-TO-DATE STANDARD EQUIPMENT LIST & KIT WEIGHTS, PERFORMANCE, AND DIRECT OPERATING COST.

BELL 206B JETRANGER III

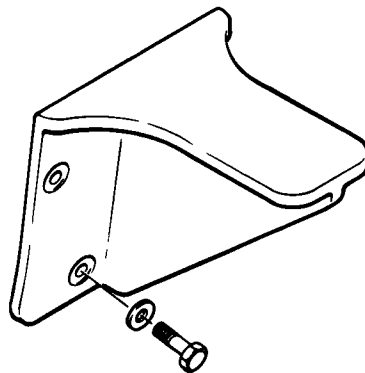
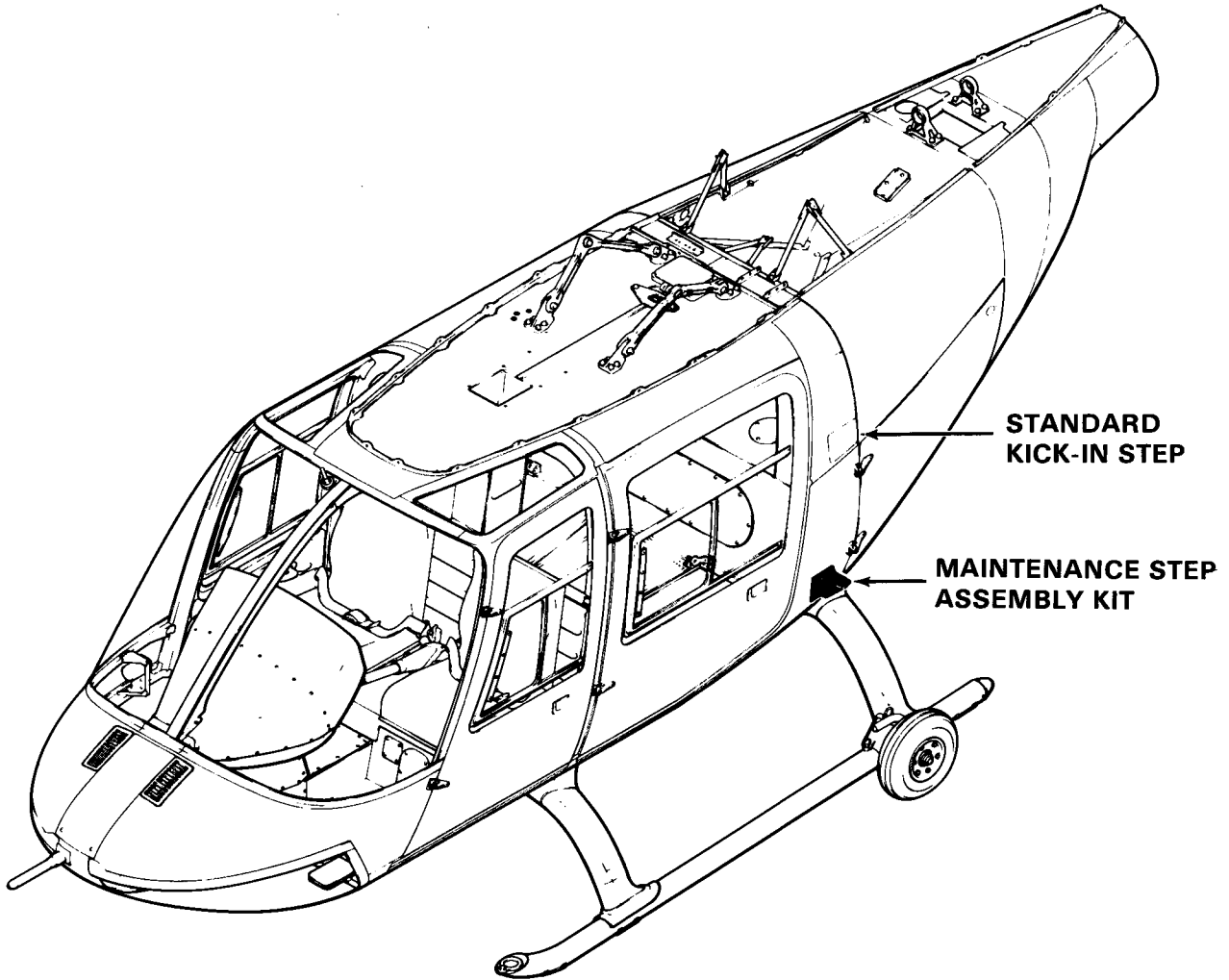

Maintenance Step



CAMERA ACCESS DOOR

BELL KIT NO. 206-706-020-001

The purpose of the Camera Access Door kit is to provide the capability of taking vertical photographs with an internally mounted camera. An opening is cut in the passenger cabin floor and the camera support is secured to the floor.

The kit consists of doublers, cover plate and other materials necessary to complete the opening.

The levelling plate is replaced on the cover plate when installation is completed.

The weight increase with the camera access door kit installed is 1 kilogram (2 pounds).

Flight Procedures are not affected.

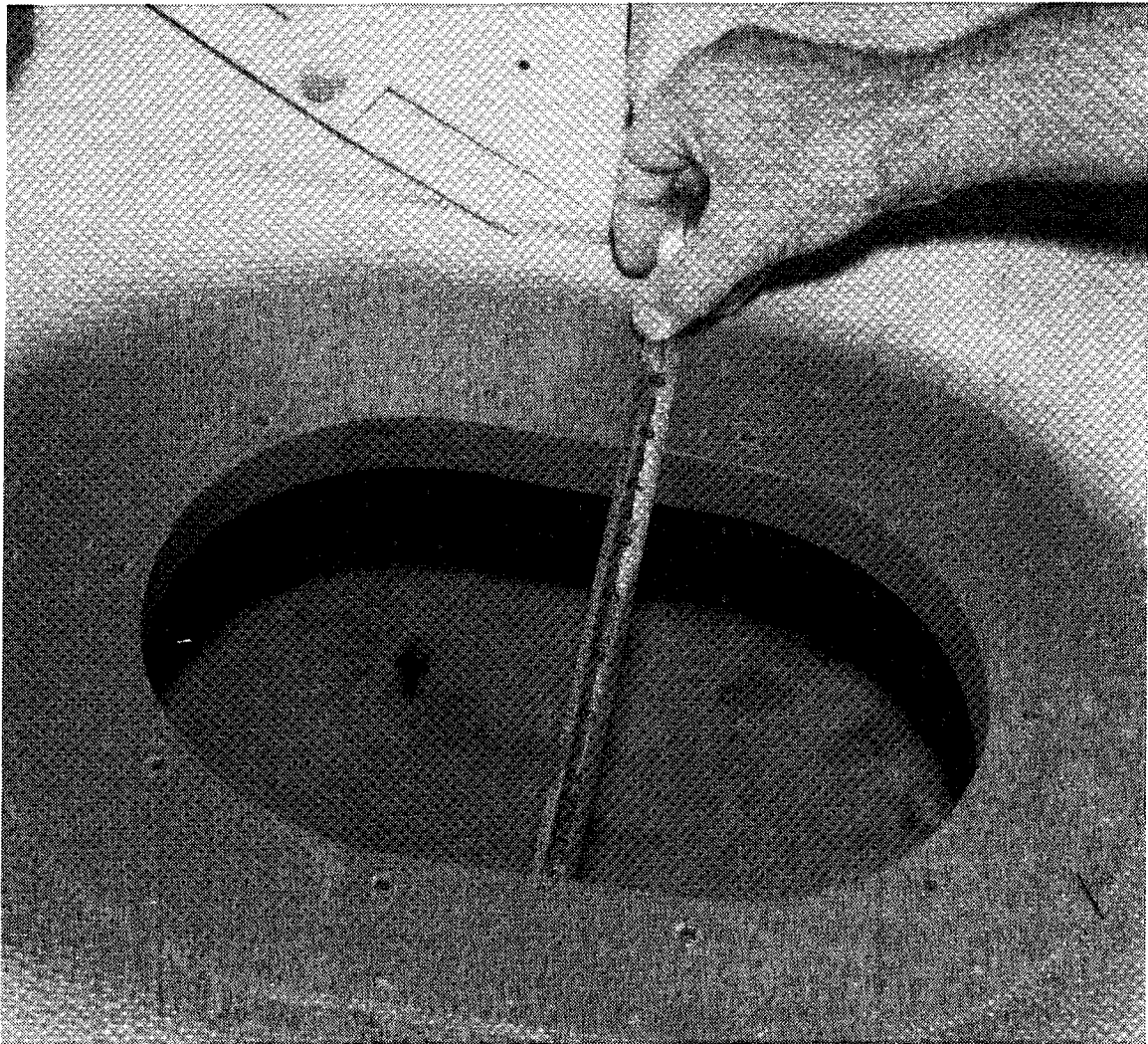



THIS IS AN UNCONTROLLED DOCUMENT. THE DATA IS PRESENTED FOR GENERAL INFORMATION ONLY. SOME INFORMATION HAS BEEN SUPERCEDED SINCE ORIGINAL PUBLICATION. PLEASE REFER TO THE CURRENT PRODUCT SPECIFICATION BOOKLET FOR UP-TO-DATE STANDARD EQUIPMENT LIST & KIT WEIGHTS, PERFORMANCE, AND DIRECT OPERATING COST.

**BELL 206B
JETRANGER III**

Camera Access Door

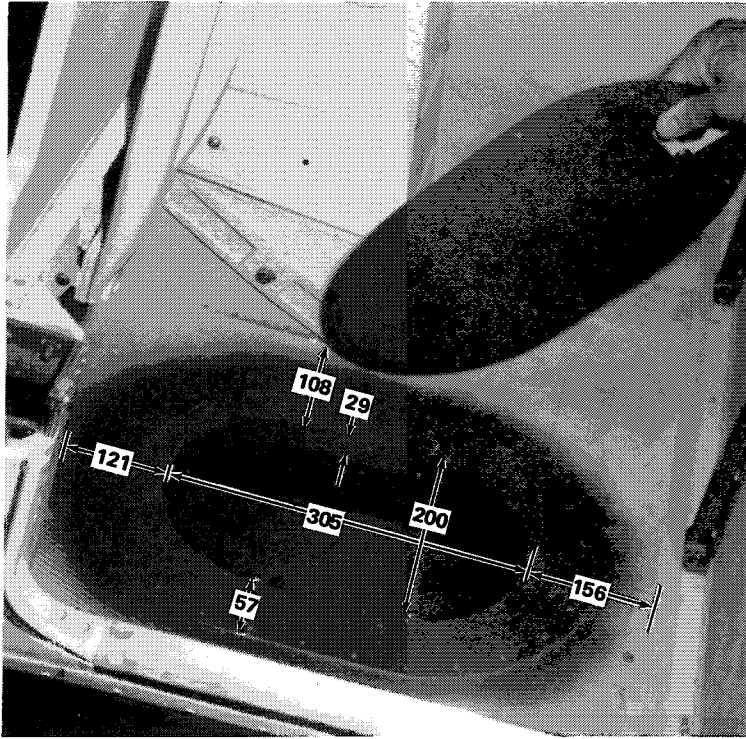

Dimensions in Millimeters

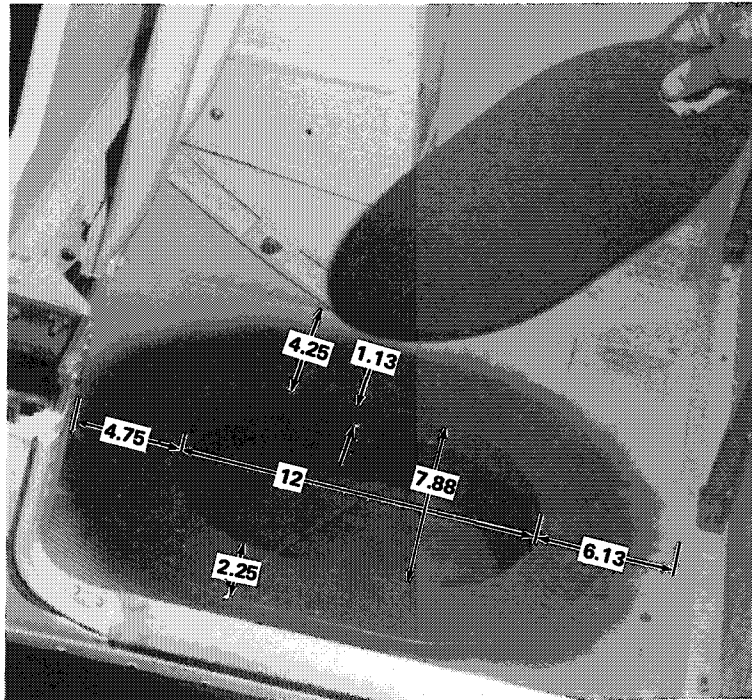

Dimensions in Inches

THIS IS AN UNCONTROLLED DOCUMENT. THE DATA IS PRESENTED FOR GENERAL INFORMATION ONLY. SOME INFORMATION HAS BEEN SUPERCEDED SINCE ORIGINAL PUBLICATION. PLEASE REFER TO THE CURRENT PRODUCT SPECIFICATION BOOKLET FOR UP-TO-DATE STANDARD EQUIPMENT LIST & KIT WEIGHTS, PERFORMANCE, AND DIRECT OPERATING COST.

SECTION FOUR

CUSTOMIZING AND VENDOR EQUIPMENT

BELL 206B, JETRANGER III



CONTENTS

BELL 206B JETRANGER III

Engine Fire Detection System	4-1
Wire Strike Protection System	4-3
Searchlight - nightsun	4-5
- nightscanner	4-7
Oil Filter	4-9
Baggage Compartment Extender	4-11
Full Length Step	4-13
Aft Cabin Intercommunication System	4-15
Loud Speakers	4-17
Emergency Locator Transmitter	4-19



ENGINE FIRE DETECTION SYSTEM

BELL KIT NO. 206-899-945-101

A customized kit to detect fire in the engine compartment is available for the JetRanger. It consists of a responder assembly with approximately 3.6 meters (12 feet) of sensor element mounted to the top of the engine cowling. The element crisscrosses the top of the whole engine compartment. A red caution light is installed in the caution panel on the bottom row second

from the left. A push to test switch/light is mounted to the immediate left of the caution lights. This light shows that the continuity of the system is intact. Wiring, hardware and installation drawings complete the kit.

The weight increase with the Engine Fire Detection System installed is 0.2 kilograms (0.5 pounds).

FAA approved.

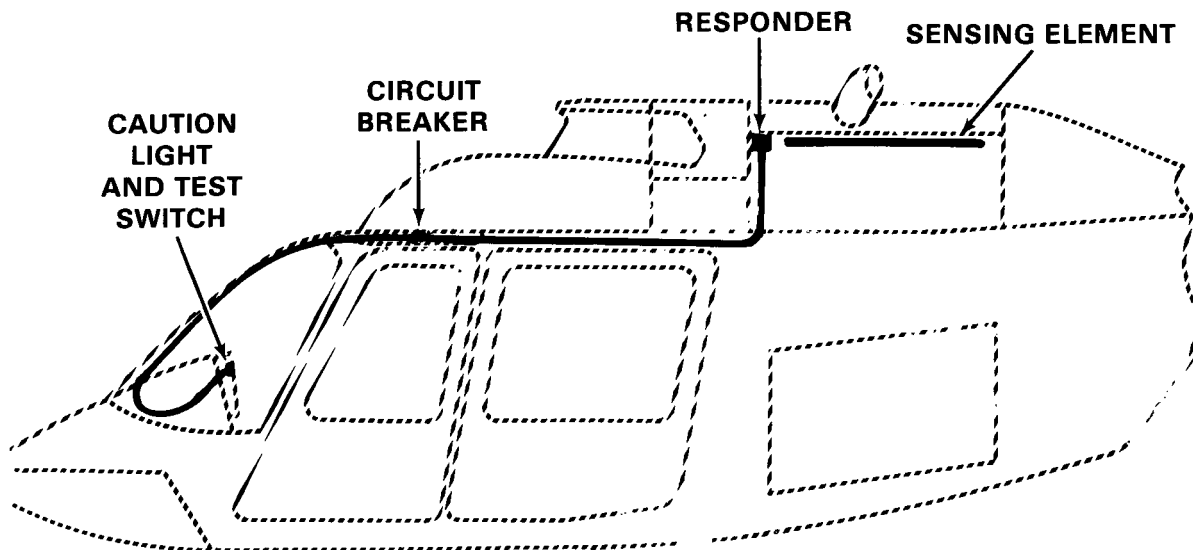



THIS IS AN UNCONTROLLED DOCUMENT. THE DATA IS PRESENTED FOR GENERAL INFORMATION ONLY. SOME INFORMATION HAS BEEN SUPERCEDED SINCE ORIGINAL PUBLICATION. PLEASE REFER TO THE CURRENT PRODUCT SPECIFICATION BOOKLET FOR UP-TO-DATE STANDARD EQUIPMENT LIST & KIT WEIGHTS, PERFORMANCE, AND DIRECT OPERATING COST.

BELL 206B
JETRANGER III

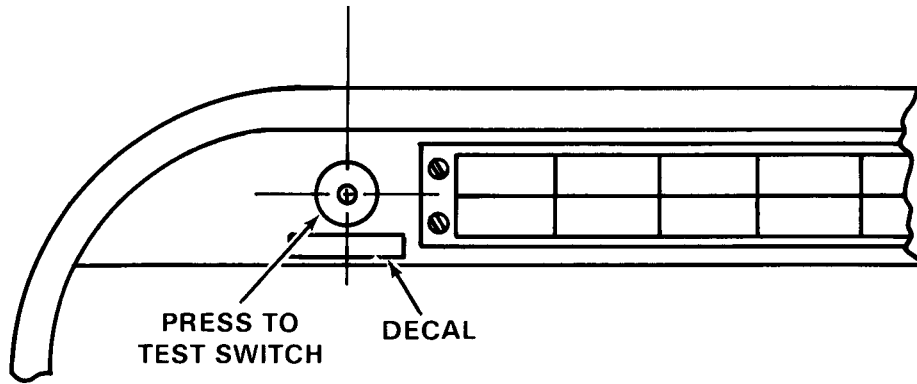

FIRE DET. TEST

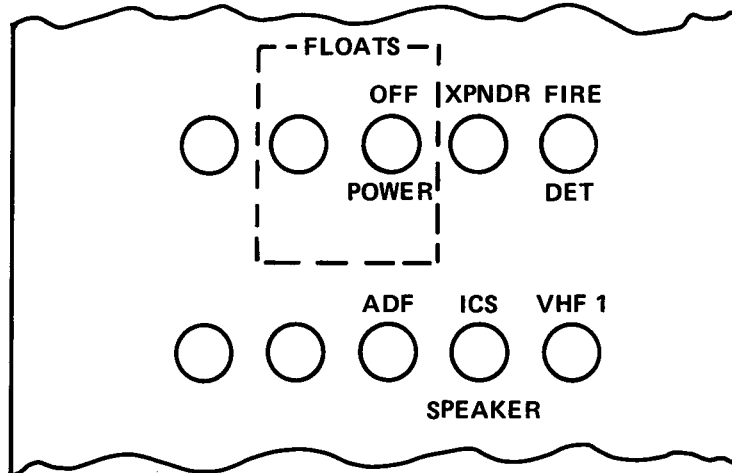



WIRE STRIKE PROTECTION SYSTEM

AA INC. 965-36502-002

The wire strike protection system provides a measure of protection against inadvertant flight into horizontally strung wires. It is designed to:

- protect the helicopter against most of the wires normally encountered in and around metropolitan areas
- help prevent entry of wire into the cockpit through the windshield
- reduce possibility of flight control damage after wire strike
- decrease the chance of wire becoming entangled with the landing gear.





THIS IS AN UNCONTROLLED DOCUMENT. THE DATA IS PRESENTED FOR GENERAL INFORMATION ONLY. SOME INFORMATION HAS BEEN SUPERCEDED SINCE ORIGINAL PUBLICATION. PLEASE REFER TO THE CURRENT PRODUCT SPECIFICATION BOOKLET FOR UP-TO-DATE STANDARD EQUIPMENT LIST & KIT WEIGHTS, PERFORMANCE, AND DIRECT OPERATING COST.

BELL 206B JETRANGER III

The kit consists of a roof-mounted deflector/cutter, a windshield-mounted protector/cutter, a belly-mounted deflector/cutter and all necessary hardware to complete the installation. An extension is included in every kit to accommodate the high skid landing gear.

The sawtoothed deflector guides the cable into the cutting wedge while inflicting damage to the cables. The wedge provides the required mechanical advantage to cut the cables without any moving parts.

There are no changes in flight characteristics or handling qualities of the JetRanger.

The system has been successfully tested at speeds as low as 8 kilometers an hour (5 mph). It is equally effective at higher speeds.

The weight increase with the Wire Strike Protection System installed is 7.3 kilograms (16 pounds).

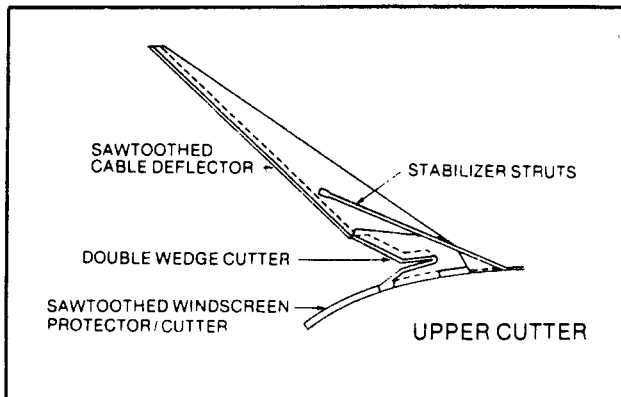

FAA approved, STC SH 4083 SW.

Aeronautical Accessories Inc.
P. O. Box 3689
Bristol, Tennessee 37625
615-538-5151
1-800-251-7094
Telex: 55-3446



THIS IS AN UNCONTROLLED DOCUMENT. THE DATA IS PRESENTED FOR GENERAL INFORMATION ONLY. SOME INFORMATION HAS BEEN SUPERCEDED SINCE ORIGINAL PUBLICATION. PLEASE REFER TO THE CURRENT PRODUCT SPECIFICATION BOOKLET FOR UP-TO-DATE STANDARD EQUIPMENT LIST & KIT WEIGHTS, PERFORMANCE, AND DIRECT OPERATING COST.

BELL 206B
JETRANGER III

SEARCHLIGHT

SPECTROLAB NIGHTSUN SX16C/106551

The Nightsun SX16C is a nose-mounted 1600 watt xenon searchlight. The direction and beam width are both remotely controlled from the cabin. The searchlight provides illumination to aid aerial observation and to facilitate movement and observation of people on the ground. It can also be used as a pointer or indicator.

The kit consists of the searchlight, mounting brackets, controls, electrical fittings and hardware required to complete the installation.

The unit is readily removed or installed.



020725



THIS IS AN UNCONTROLLED DOCUMENT. THE DATA IS PRESENTED FOR GENERAL INFORMATION ONLY. SOME INFORMATION HAS BEEN SUPERCEDED SINCE ORIGINAL PUBLICATION. PLEASE REFER TO THE CURRENT PRODUCT SPECIFICATION BOOKLET FOR UP-TO-DATE STANDARD EQUIPMENT LIST & KIT WEIGHTS, PERFORMANCE, AND DIRECT OPERATING COST.

BELL 206B
JETRANGER III

The average beam power is 25000 lumens which means that on a dark night an area 90 meters (300 feet) in diameter could be made fifty times brighter than full moonlight from an altitude of 1000 meters (3000 feet).

The weight increase with the provisions installed is 7.7 kilograms (17 pounds). The removable light adds an additional 16.3 kilograms (36 pounds).

FAA approved.

Options include a clip-on infrared filter and a remote controlled infrared filter that permits changing from infrared to white light and vice versa at any time during flight.

Spectrolab
12484 Gladstone Ave.
Sylmar
California 91342



SEARCHLIGHT

NIGHTSCANNER AA-206-SL

The Nightscanner is a lightweight, fully controllable light that is usually mounted on the belly of the helicopter. It has forward and aft movement as well as full 360 degrees of rotation, and is easily controllable with switches normally mounted on the pilot's collective stick.

It is completely stowable. One switch is ON/OFF/STOW. The other is a "Chinese hat" type for fore and aft and rotational movement.

It has 400,000 candlepower of illumination for use as a landing light or a low cost, lightweight searchlight.

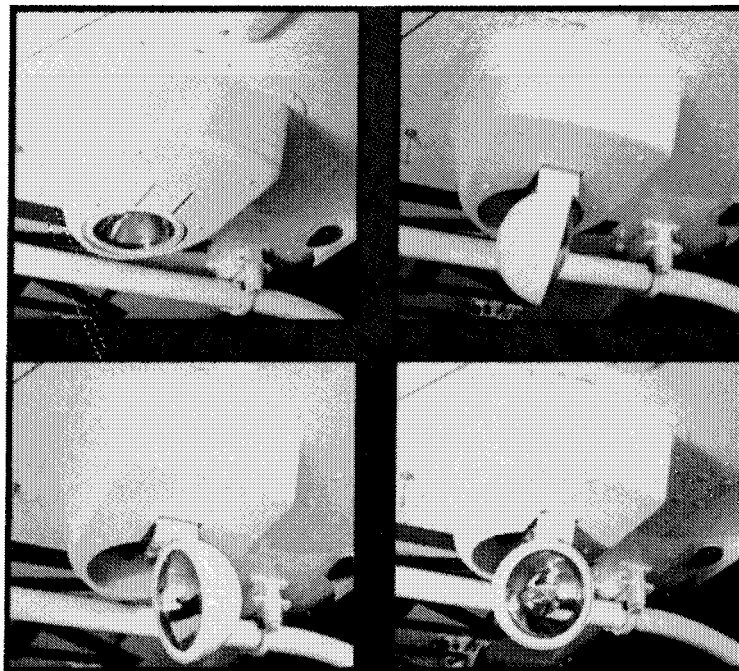



THIS IS AN UNCONTROLLED DOCUMENT. THE DATA IS PRESENTED FOR GENERAL INFORMATION ONLY. SOME INFORMATION HAS BEEN SUPERCEDED SINCE ORIGINAL PUBLICATION. PLEASE REFER TO THE CURRENT PRODUCT SPECIFICATION BOOKLET FOR UP-TO-DATE STANDARD EQUIPMENT LIST & KIT WEIGHTS, PERFORMANCE, AND DIRECT OPERATING COST.

BELL 206B
JETRANGER III

The weight increase with the Night-scanner installed is approximately 4.5 kilograms (10 pounds).

FAA approved, STC SH131250.

Aeronautical Accessories Inc.
P. O. Box 3689
Bristol, Tennessee 37625
615-538-5151
1-800-251-7094
Telex: 55-3446



OIL FILTER

FACET NI-CAD 1741010

The Facet Ni-Cad oil filter is added to the existing engine oil system to increase economy and efficiency by maintaining cleaner oil. It supplements the existing oil filter. The 10 micron filter element cleans the oil to a much finer degree than the standard filter alone.

The filter bolts to the airframe between the engine and the oil cooler.

When the Facet Ni-Cad system is added it increases the time between oil changes and cleaning the lines to the bearings to 200 hours. This saves oil, reduces labor costs and downtime and extends bearing life. It also reduces the chance of premature engine failure.

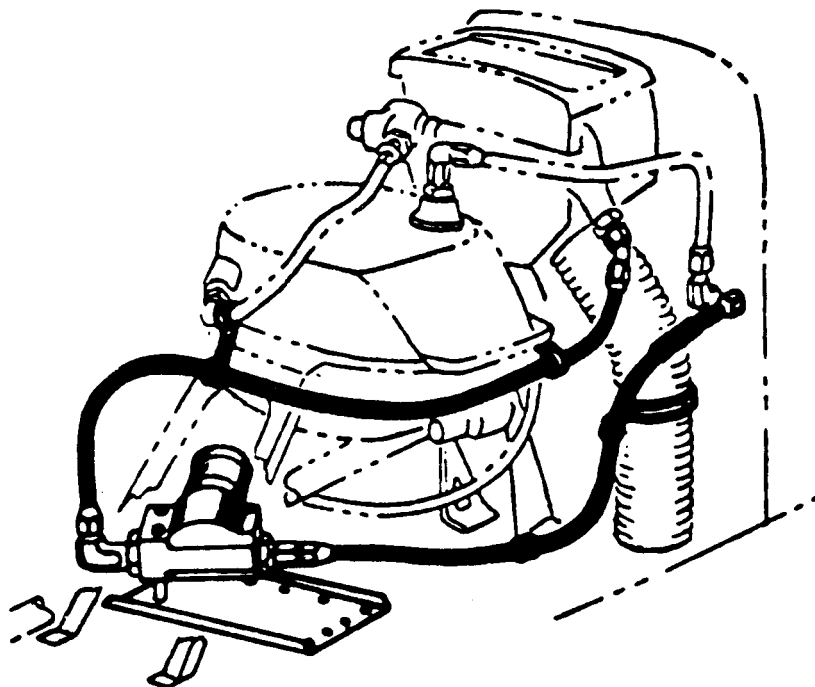



THIS IS AN UNCONTROLLED DOCUMENT. THE DATA IS PRESENTED FOR GENERAL INFORMATION ONLY. SOME INFORMATION HAS BEEN SUPERCEDED SINCE ORIGINAL PUBLICATION. PLEASE REFER TO THE CURRENT PRODUCT SPECIFICATION BOOKLET FOR UP-TO-DATE STANDARD EQUIPMENT LIST & KIT WEIGHTS, PERFORMANCE, AND DIRECT OPERATING COST.

**BELL 206B
JETRANGER III**

The kit consists of the filter and all the hoses and hardware required to complete the installation.

FAA approved, STC SH300GL.

The weight increase with the Facet Ni-Cad oil filter installed is 2.8 kilograms (5.2 pounds).

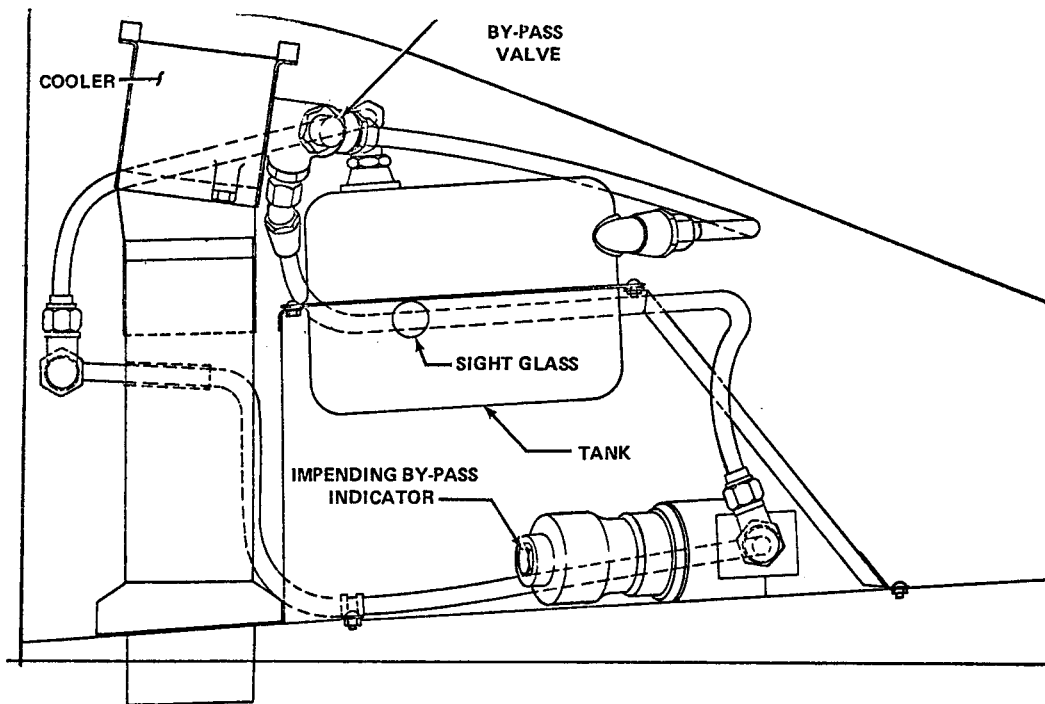

Filter Products Division
Facet Enterprises, Inc.
434 West Twelve Mile Road
Madison Heights, Michigan 48071



BAGGAGE COMPARTMENT EXTENDER

SPACEMAKER HGA206EXT

The SPACEMAKER is a baggage compartment extender. It is a durable, one-piece molded fiberglass unit which is fitted in the tail boom immediately aft of the baggage compartment. It increases the length of the standard compartment approximately 50%.

The SPACEMAKER is designed to accommodate large or bulky cargo, especially the long items such as golf

clubs, surveyor's transits, long-handled shovels, etc. The unit is color matched and includes a lightweight cover that can close off the extended area, if desired.

The weight increase with the Spacemaker installed is 2.7 kilograms (6 pounds).

FAA approved, STC SH227WE.

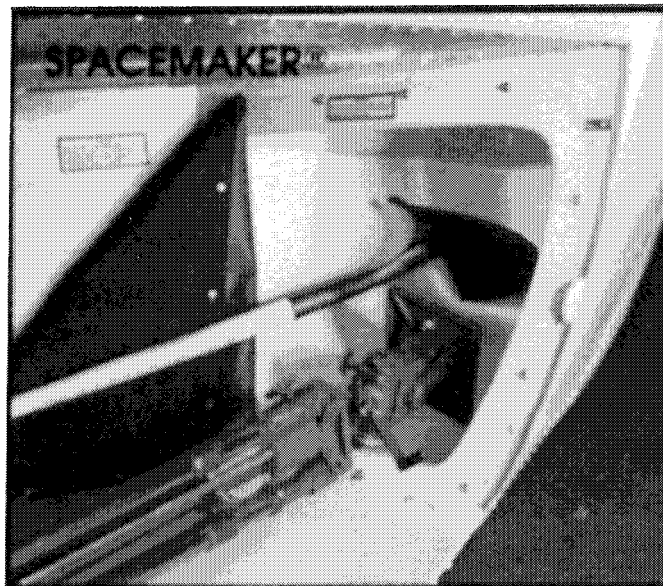



THIS IS AN UNCONTROLLED DOCUMENT. THE DATA IS PRESENTED FOR GENERAL INFORMATION ONLY. SOME INFORMATION HAS BEEN SUPERCEDED SINCE ORIGINAL PUBLICATION. PLEASE REFER TO THE CURRENT PRODUCT SPECIFICATION BOOKLET FOR UP-TO-DATE STANDARD EQUIPMENT LIST & KIT WEIGHTS, PERFORMANCE, AND DIRECT OPERATING COST.

BELL 206B
JETRANGER III

Aeronautical Accessories Inc.
P. O. Box 3689
Bristol, Tennessee 37625
615-538-5151
1-800-251-7094
Telex: 55-3446



FULL-LENGTH STEP

FLITESTEP AA-206-FS

The Flitestep kit consists of two full-length steps that fit on the landing gear crosstubes. They are designed to eliminate the difficulties of loading and unloading passengers when the Jet-Ranger is on high skid gear. It also eases access to the engine compartment. The Flitesteps are constructed of lightweight aluminum and can be installed in less than 30 minutes.

The kit consists of right and left steps and the required fittings to install them. The four standard fuselage-mounted high skid steps are removed.

The weight increase with both Flitesteps installed is 4.4 kilograms (9.75 pounds).

FAA approved, STC SH113450.

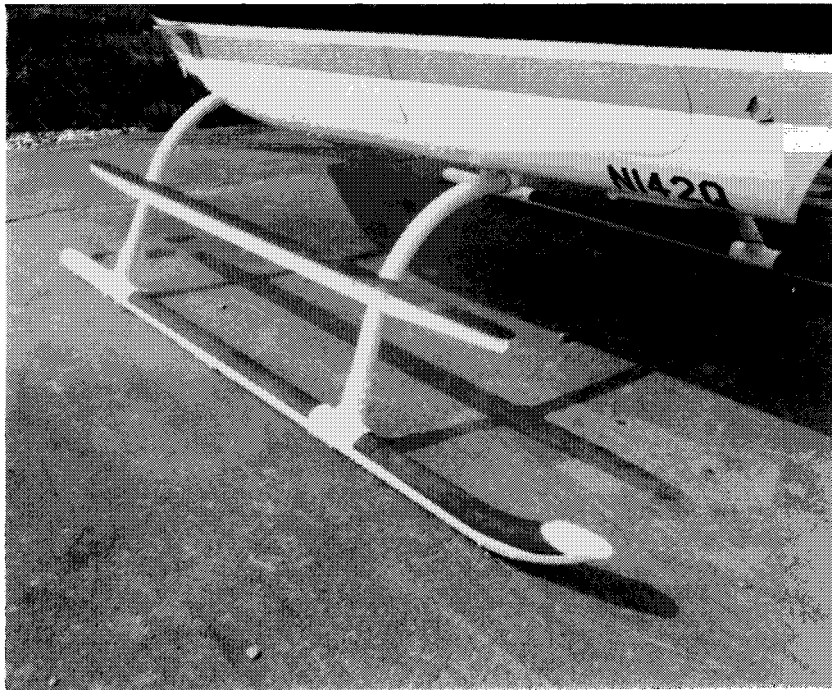



THIS IS AN UNCONTROLLED DOCUMENT. THE DATA IS PRESENTED FOR GENERAL INFORMATION ONLY. SOME INFORMATION HAS BEEN SUPERCEDED SINCE ORIGINAL PUBLICATION. PLEASE REFER TO THE CURRENT PRODUCT SPECIFICATION BOOKLET FOR UP-TO-DATE STANDARD EQUIPMENT LIST & KIT WEIGHTS, PERFORMANCE, AND DIRECT OPERATING COST.

BELL 206B
JETRANGER III

Aeronautical Accessories Inc.
P. O. Box 3689
Bristol, Tennessee 37625
615-538-5151
1-800-251-7094
Telex: 55-3446



THIS IS AN UNCONTROLLED DOCUMENT. THE DATA IS PRESENTED FOR GENERAL INFORMATION ONLY. SOME INFORMATION HAS BEEN SUPERCEDED SINCE ORIGINAL PUBLICATION. PLEASE REFER TO THE CURRENT PRODUCT SPECIFICATION BOOKLET FOR UP-TO-DATE STANDARD EQUIPMENT LIST & KIT WEIGHTS, PERFORMANCE, AND DIRECT OPERATING COST.

BELL 206B
JETRANGER III

AFT CABIN INTERCOMMUNICATION SYSTEM

BELL KIT NO. 206-899-619

The **Aft Cabin Intercommunication System** provides communication between crew and passengers. It consists of one or two David Clark headsets with an in line push-to-talk switch on each, mounted in the parcel shelf.

Wiring is not included in the kit since it must be interfaced into the selected avionics/audio system.

The weight increase with the Aft Cabin Intercommunication System installed with one headset is approximately 0.5 kilograms (1.1 pounds), and with two headsets is 1 kilogram (2.2 pounds).



THIS IS AN UNCONTROLLED DOCUMENT. THE DATA IS PRESENTED FOR GENERAL INFORMATION ONLY. SOME INFORMATION HAS BEEN SUPERCEDED SINCE ORIGINAL PUBLICATION. PLEASE REFER TO THE CURRENT PRODUCT SPECIFICATION BOOKLET FOR UP-TO-DATE STANDARD EQUIPMENT LIST & KIT WEIGHTS, PERFORMANCE, AND DIRECT OPERATING COST.

BELL 206B
JETRANGER III



LOUDSPEAKERS

BELL KIT NO. 206-899-415-5

A customized kit is available to mount the AEM-400 loudspeaker system on the JetRanger.

The speakers are mounted on the forward crosstube of the landing gear, facing forward.

The kit consists of a dual speaker unit, an amplifier, light to indicate power on, ON OFF switch, volume control, microphone and the necessary hardware to complete the installation.

To obtain adequate ground clearance, the high skid landing gear or the emergency flotation gear is required.

The kit is designed to direct ground personnel while the helicopter remains airborne.

Limitations are listed in the Flight Manual Supplement.

The weight increase with the Loudspeaker kit installed is 14.2 kilograms (31.2 pounds).

Bell Kit No. 206-899-415-1 mounts the same speakers on the left hand side of the roof near the engine inlet. It is not compatible with the hoist.

Bell Kit No. 206-899-415-3 mounts the speakers on the right side of the roof.



THIS IS AN UNCONTROLLED DOCUMENT. THE DATA IS PRESENTED FOR GENERAL INFORMATION ONLY. SOME INFORMATION HAS BEEN SUPERCEDED SINCE ORIGINAL PUBLICATION. PLEASE REFER TO THE CURRENT PRODUCT SPECIFICATION BOOKLET FOR UP-TO-DATE STANDARD EQUIPMENT LIST & KIT WEIGHTS, PERFORMANCE, AND DIRECT OPERATING COST.

BELL 206B
JETRANGER III



EMERGENCY LOCATOR TRANSMITTER

BELL KIT NO. 206-899-577-3

The customized Emergency Locator Transmitter (ELT) installation provides an automatic beacon in the event of a crash. The built-in computer analyzes the nature of the shock and operates the beacon in loads of 6 ± 1 G in any direction.

The EBC 302H series by Emergency Beacon Corporation is specially designed for helicopter use. It activates at $6 \pm G$ loads 360° in azimuth as well as full vertical components.

The ELT is a completely self-contained, battery powered unit with an integral antenna that is always fully deployed, ready for instant signal transmission. The ELT has a switch so that it can be turned on manually. It also has a built-in test light for checking the power output, modulation and the state of the battery.

The battery has a three year shelf life. It provides the beacon with a range up to 480 km (300 miles) for eight days.

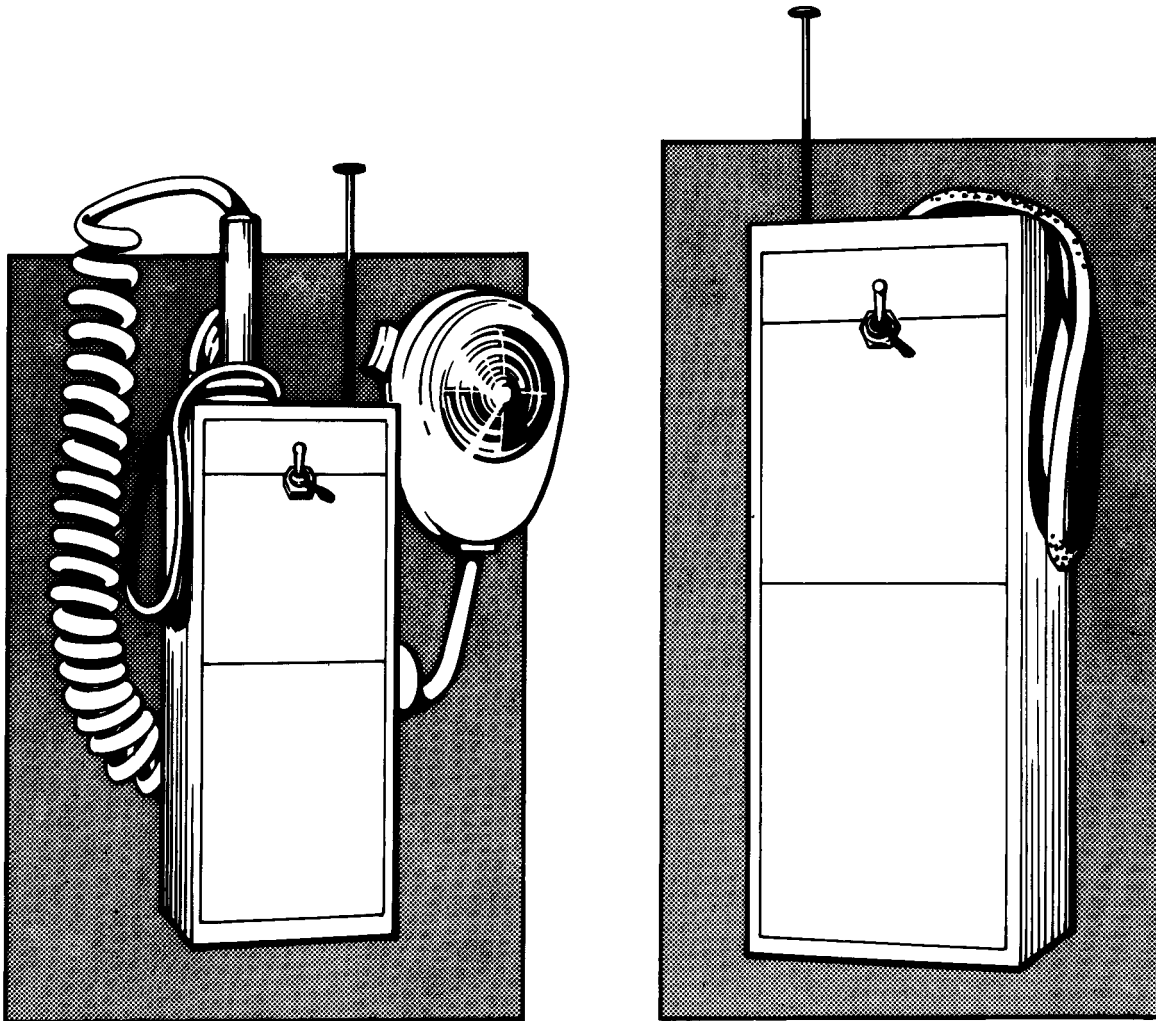



THIS IS AN UNCONTROLLED DOCUMENT. THE DATA IS PRESENTED FOR GENERAL INFORMATION ONLY. SOME INFORMATION HAS BEEN SUPERCEDED SINCE ORIGINAL PUBLICATION. PLEASE REFER TO THE CURRENT PRODUCT SPECIFICATION BOOKLET FOR UP-TO-DATE STANDARD EQUIPMENT LIST & KIT WEIGHTS, PERFORMANCE, AND DIRECT OPERATING COST.

BELL 206B
JETRANGER III

It can withstand 1000 G and function in temperatures ranging from -45°C to 71°C (-50°F to 160°F).

The installation consists of a bracket which holds the ELT securely in position. It is mounted on the left forward doorpost.

The completely self-contained ELT can be removed and hand carried.

There is a choice of three units. All are the same size and weight. The EBC 302H transmits the emergency signal simultaneously on 121.5 and 243.0 MHz. The EBC 302VH has in addition a microphone jack which takes the standard microphone. This provides voice transmission capability. The EBC 302VRH adds a headset jack so that two-way conversation can be carried out on 121.5 MHz.

The ELT weighs 0.86 kilograms (1.9 pounds).

Emergency Beacon Corp.
13 River Street
New Rochelle, New York 10801
914-235-9400

THIS IS AN UNCONTROLLED DOCUMENT. THE DATA IS PRESENTED FOR GENERAL INFORMATION ONLY. SOME INFORMATION HAS BEEN SUPERCEDED SINCE ORIGINAL PUBLICATION. PLEASE REFER TO THE CURRENT PRODUCT SPECIFICATION BOOKLET FOR UP-TO-DATE STANDARD EQUIPMENT LIST & KIT WEIGHTS, PERFORMANCE, AND DIRECT OPERATING COST.

SECTION FIVE

DIMENSIONS AND WEIGHTS

BELL 206B, JETRANGER III



THIS IS AN UNCONTROLLED DOCUMENT. THE DATA IS PRESENTED FOR GENERAL INFORMATION ONLY. SOME INFORMATION HAS BEEN SUPERCEDED SINCE ORIGINAL PUBLICATION. PLEASE REFER TO THE CURRENT PRODUCT SPECIFICATION BOOKLET FOR UP-TO-DATE STANDARD EQUIPMENT LIST & KIT WEIGHTS, PERFORMANCE, AND DIRECT OPERATING COST.



THIS IS AN UNCONTROLLED DOCUMENT. THE DATA IS PRESENTED FOR GENERAL INFORMATION ONLY. SOME INFORMATION HAS BEEN SUPERCEDED SINCE ORIGINAL PUBLICATION. PLEASE REFER TO THE CURRENT PRODUCT SPECIFICATION BOOKLET FOR UP-TO-DATE STANDARD EQUIPMENT LIST & KIT WEIGHTS, PERFORMANCE, AND DIRECT OPERATING COST.

BELL 206B JETRANGER III

EXTERIOR DIMENSIONS

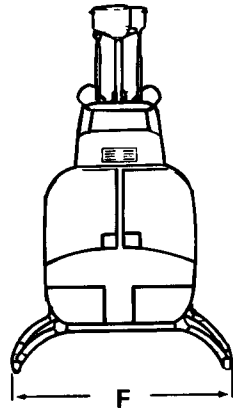
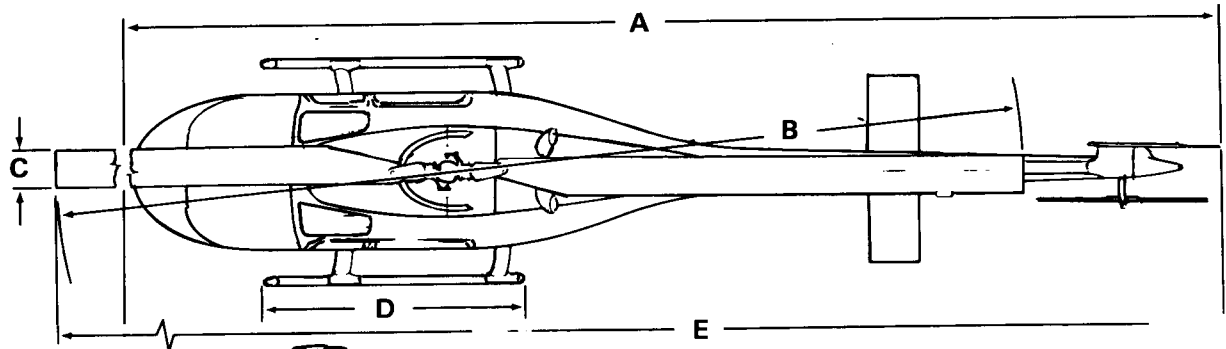

	METERS	FEET
A	9.50	31.2
B	10.16	33.3
C	0.33	1.1
D	2.26	7.4
E	11.90	39.1
F	1.83	6.0
G	2.83	9.3
H	0.40	1.3
J	1.70	5.5
K	0.76	2.5
L	2.80	9.2

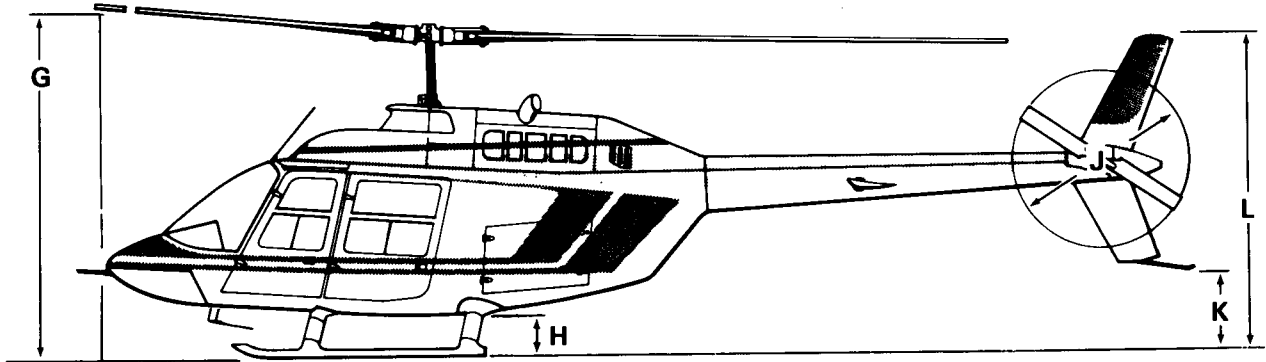

DIMENSIONS	METERS						FEET					
	D	F	G	H	K	L	D	F	G	H	K	L
STANDARD SKID	2.26	1.83	2.83	0.40	0.76	2.80	7.4	6	9.3	1.3	2.5	9.2
HIGH SKID	2.59	1.89	3.05	0.55	1.28	3.35	8.5	6.2	10	1.8	4.2	11
STANDARD FLOATS	5.49	3.35	3.14	0.67	1.43	3.47	18	11	10.3	2.2	4.7	11.4
EMERGENCY FLOATS	3.4	2.05	3.05	0.37	1.28	3.35	11.2	6.7	10	1.2	4.2	11
INFLATED	4.87	2.81	3.05		1.28	3.35	16	9.2	10		4.2	11



THIS IS AN UNCONTROLLED DOCUMENT. THE DATA IS PRESENTED FOR GENERAL INFORMATION ONLY. SOME INFORMATION HAS BEEN SUPERCEDED SINCE ORIGINAL PUBLICATION. PLEASE REFER TO THE CURRENT PRODUCT SPECIFICATION BOOKLET FOR UP-TO-DATE STANDARD EQUIPMENT LIST & KIT WEIGHTS, PERFORMANCE, AND DIRECT OPERATING COST.

**BELL 206B
JETRANGER III**

INTERIOR DIMENSIONS

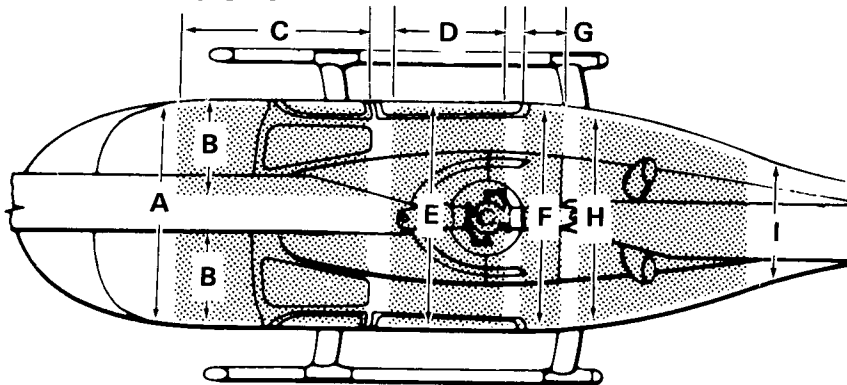

Passenger compartment
Approximately 1.12 cubic meters
(40 cubic feet).

Passenger and baggage compartments
Loading up to 420 kilograms
per square meter (86 pounds
per square foot).

		Meters	Feet
A.	Forward Cabin Width	1.22	4.0
B.	Forward Seat — Width (each)	0.38	1.3
C.	Forward Seat & Leg Room	1.09	3.6
D.	Aft Seat & Leg Room	0.99	3.3
E.	Aft Seat — Width	1.19	3.9
F.	Baggage Shelf — Width	1.04	3.4
G.	Baggage Shelf — Depth	0.25	0.8
H.	Baggage Compartment — Fwd Width	1.04	3.4
I.	Baggage Compartment — Aft Width	0.48	1.6

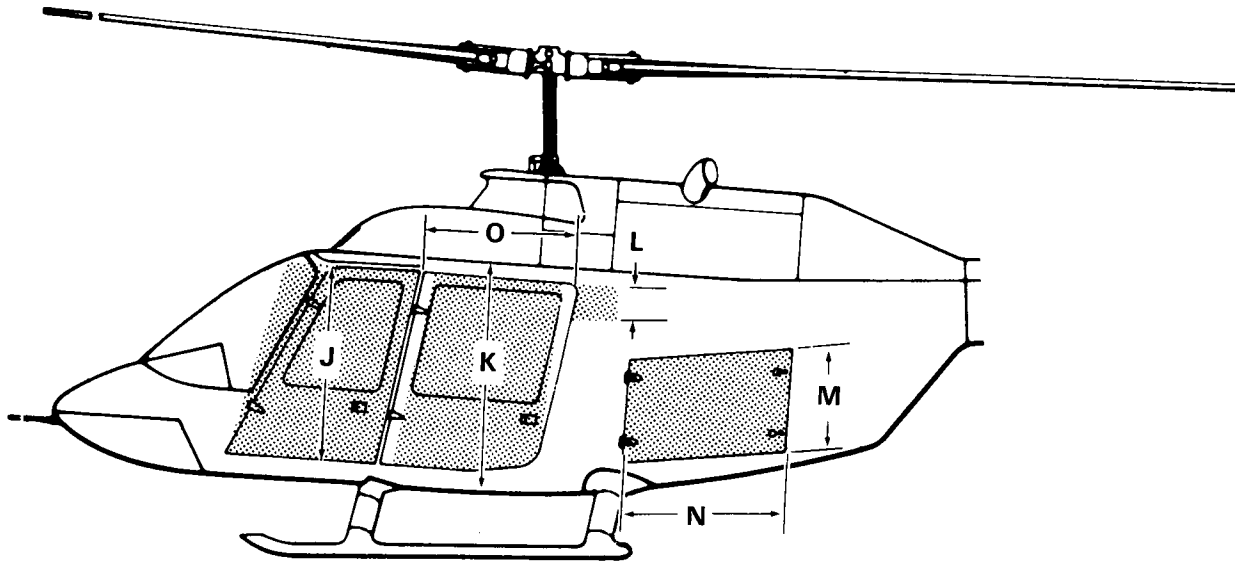

Baggage compartment
0.45 cubic meters
(16 cubic feet).

		Meters	Feet
J.	Door Opening Height	1.14	3.8
K.	Ceiling to Floor	1.30	4.3
L.	Baggage Shelf Height	0.38	1.3
M.	Baggage Compartment — Height	0.56	1.8
N.	Baggage Compartment — Length	0.91	3.0
O.	Aft Door Opening — Width	0.89	2.9



THIS IS AN UNCONTROLLED DOCUMENT. THE DATA IS PRESENTED FOR GENERAL INFORMATION ONLY. SOME INFORMATION HAS BEEN SUPERCEDED SINCE ORIGINAL PUBLICATION. PLEASE REFER TO THE CURRENT PRODUCT SPECIFICATION BOOKLET FOR UP-TO-DATE STANDARD EQUIPMENT LIST & KIT WEIGHTS, PERFORMANCE, AND DIRECT OPERATING COST.

BELL 206B JETRANGER III

WEIGHTS

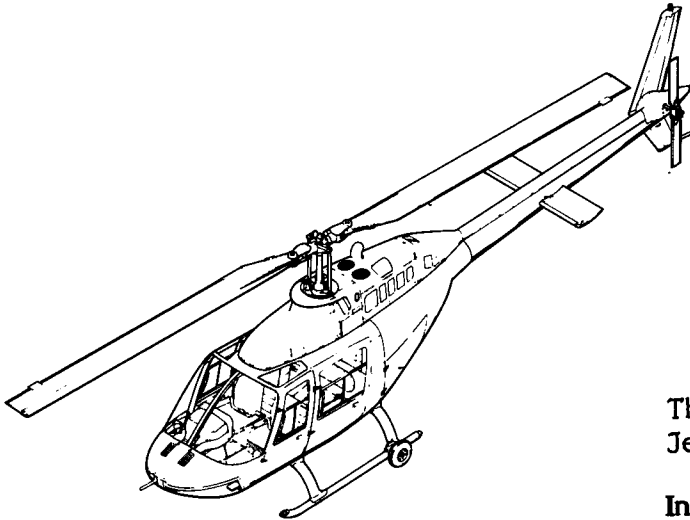

The Maximum Gross Weight for the JetRanger III:

Internal loading - 1,452 kilograms (3,200 pounds).

External loading - 1,520 kilograms (3,350 pounds) up to 680 kg (1,500 lb) on the hook.

The JetRanger in standard configuration as described.

Empty weight 732.8 kg (1,615 lb).
Trapped oil 5.9 kg (13 lb).
Trapped fuel 3.3 kg (7 lb).
Total 742 kg (1,635 lb).*

Full Fuel

348 liters (92.03 U.S. gal) of which 344 liters (91 U.S. gal) are usable at 0.815 kg/l (6.8 lb/gal) = 280 kg (619 lb) usable fuel.



*The weight includes all the equipment described in the standard configuration and trapped fluids. It does not include ballast because ballast is a function of installed optional equipment.



OPTIONAL EQUIPMENT WEIGHTS

High skids	Flight instrument group
8 kg (17.6 lb)	4.4 kg (9.6 lb)
Emergency floats	VFR autopilot system
65.5 kg (144.4 lb)	43.5 kg (96 lb)
Fixed floats	VHF
50.3 kg (111 lb)	Comm/nav transceiver
Dual Controls	provisions only
4 kg (8.9 lb)	5.9 kg (13 lb)
Rotor brake	complete
6 kg (13.2 lb)	9.1 kg (20 lb)
Particle Separator	Course deviation indicator
3 kg (6.5 lb)	0.5 kg (1 lb)
Snow baffles	Automatic direction finder
1.4 kg (3 lb)	3 kg (6.6 lb)
Automatic engine re-ignition	Transponder
1.7 kg (3.7 lb)	provisions only
	0.4 kg (0.9 lb)
	complete
	1.68 kg (3.72 lb)

THIS IS AN UNCONTROLLED DOCUMENT. THE DATA IS PRESENTED FOR GENERAL INFORMATION ONLY. SOME INFORMATION HAS BEEN SUPERCEDED SINCE ORIGINAL PUBLICATION. PLEASE REFER TO THE CURRENT PRODUCT SPECIFICATION BOOKLET FOR UP-TO-DATE STANDARD EQUIPMENT LIST & KIT WEIGHTS, PERFORMANCE, AND DIRECT OPERATING COST.

SECTION SIX

PERFORMANCE

BELL 206B, JETRANGER III





THIS IS AN UNCONTROLLED DOCUMENT. THE DATA IS PRESENTED FOR GENERAL INFORMATION ONLY. SOME INFORMATION HAS BEEN SUPERCEDED SINCE ORIGINAL PUBLICATION. PLEASE REFER TO THE CURRENT PRODUCT SPECIFICATION BOOKLET FOR UP-TO-DATE STANDARD EQUIPMENT LIST & KIT WEIGHTS, PERFORMANCE, AND DIRECT OPERATING COST.

BELL 206B *JETRANGER III*

206B, JETRANGER III PERFORMANCE

Performance data for the JetRanger III are presented in the following pages. The tabulated performance, on the next page, is a summary using two representative gross weights. It is based on standard day conditions and on the power available and the fuel flow as reported in the Allison Engine Specification with installation losses applied.

The JetRanger III is designed to operate within an ambient temperature range of

-32° to +50°C (-25° to +122°F) and is transferable from one climate to another without extensive modification. It is frequently operated at much colder temperatures. There are no flight manual temperature limitations.

At the maximum gross weight for internal loading (1,452 kg, 3,200 lb), the JetRanger III has the following limit maneuvering load factors:

Positive	3.5g
Negative	0.5g



THIS IS AN UNCONTROLLED DOCUMENT. THE DATA IS PRESENTED FOR GENERAL INFORMATION ONLY. SOME INFORMATION HAS BEEN SUPERCEDED SINCE ORIGINAL PUBLICATION. PLEASE REFER TO THE CURRENT PRODUCT SPECIFICATION BOOKLET FOR UP-TO-DATE STANDARD EQUIPMENT LIST & KIT WEIGHTS, PERFORMANCE, AND DIRECT OPERATING COST.

BELL 206B
JETRANGER III

TABULATED PERFORMANCE

Standard Configuration Weight		kg	742	742	lb	1,635	1,635
Takeoff Gross Weight		kg	1,180	1,450	lb	2,600	3,200
Useful Load		kg	438	708	lb	965	1,565
Maximum Takeoff Altitude (IGE Hovering Ceiling)	—ISA	m	6,100	3,900	ft	20,000	12,800
	—ISA + 20°C	m	5,000	3,100	ft	16,400	10,200
	—ISA + 30°C	m	4,600	945	ft	15,100	8,800
OGE Hovering Ceiling	—ISA	m	5,820	2,680	ft	19,100	8,800
	—ISA + 20°C	m	3,660	1,150	ft	12,000	3,800
	—ISA + 30°C	m	3,170	945	ft	10,400	3,100
Rate of Climb, TOP, SL	—ISA	m/s	10.6	6.5	ft/min	2,080	1,280
	—ISA + 20°C	m/s	10.6	6.5	ft/min	2,080	1,280
	—ISA + 30°C	m/s	10.6	6.5	ft/min	2,080	1,280
Service Ceiling, MCP	—ISA	m	6,100+	4,115	ft	20,000+	13,500
	—ISA + 20°C	m	6,100+	3,900	ft	20,000+	12,800
	—ISA + 30°C	m	5,270	3,050	ft	17,300	10,000
Specific Range, SL at Maximum Continuous Power	—ISA	km/kg	2.49	2.43	nm/lb	0.610	0.595
	—ISA + 20°C	km/kg	2.51	2.43	nm/lb	0.614	0.594
	—ISA + 30°C	km/kg	2.51	2.43	nm/lb	0.614	0.594
Range with Full Fuel	—ISA	km	700	682	nm	378	368
	—ISA + 20°C	km	704	682	nm	380	368
	—ISA + 30°C	km	704	682	nm	380	368
True Airspeed Average	—ISA	km/h	215	209	kn	116	113
	—ISA + 20°C	km/h	224	217	kn	121	117
	—ISA + 30°C	km/h	224	217	kn	121	117
Loiter, SL							
Loiter Airspeed	—ISA	km/h	89	89	kn	48	48
Maximum Loiter Endurance	—ISA	h	4.9	4.6	h	4.9	4.6

Range is calculated using 344 liters (91 gal) of Jet A fuel at 0.815 kg/l (6.8lb/gal)



ICE HOVERING
HOVERING
CEILING

PRESSURE
ALTITUDE
IN FEET

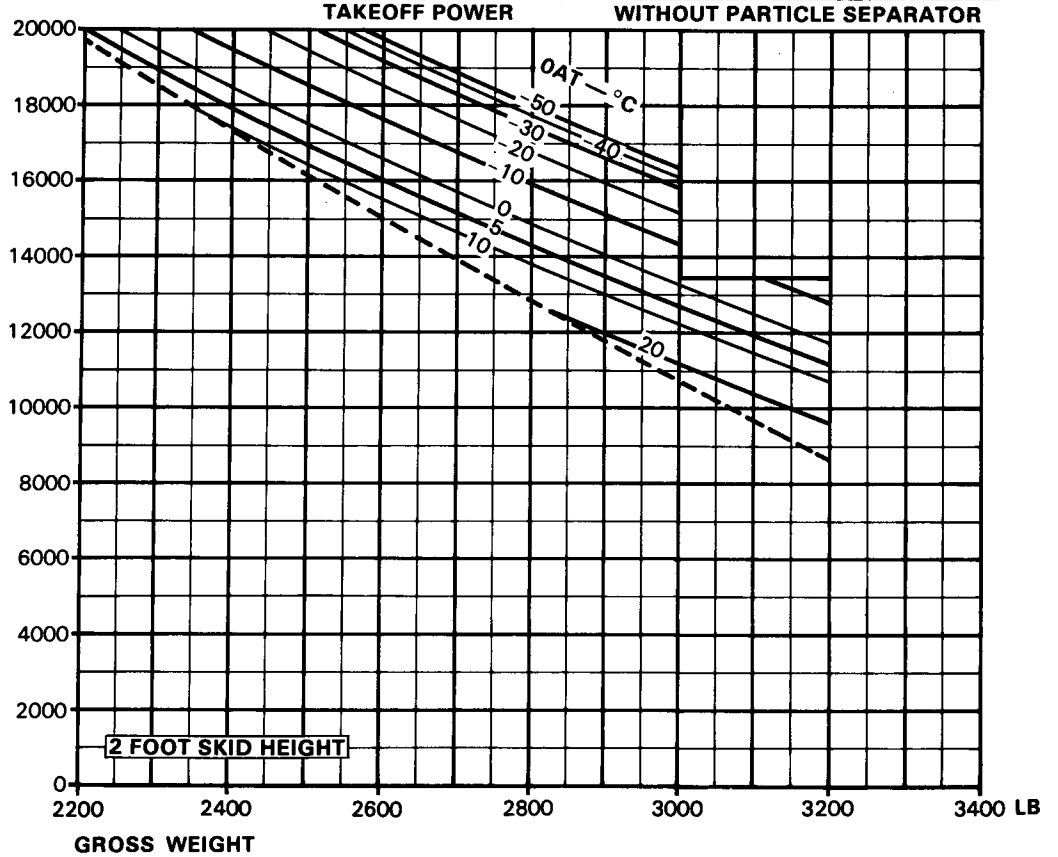

PRESSURE
ALTITUDE
IN METERS

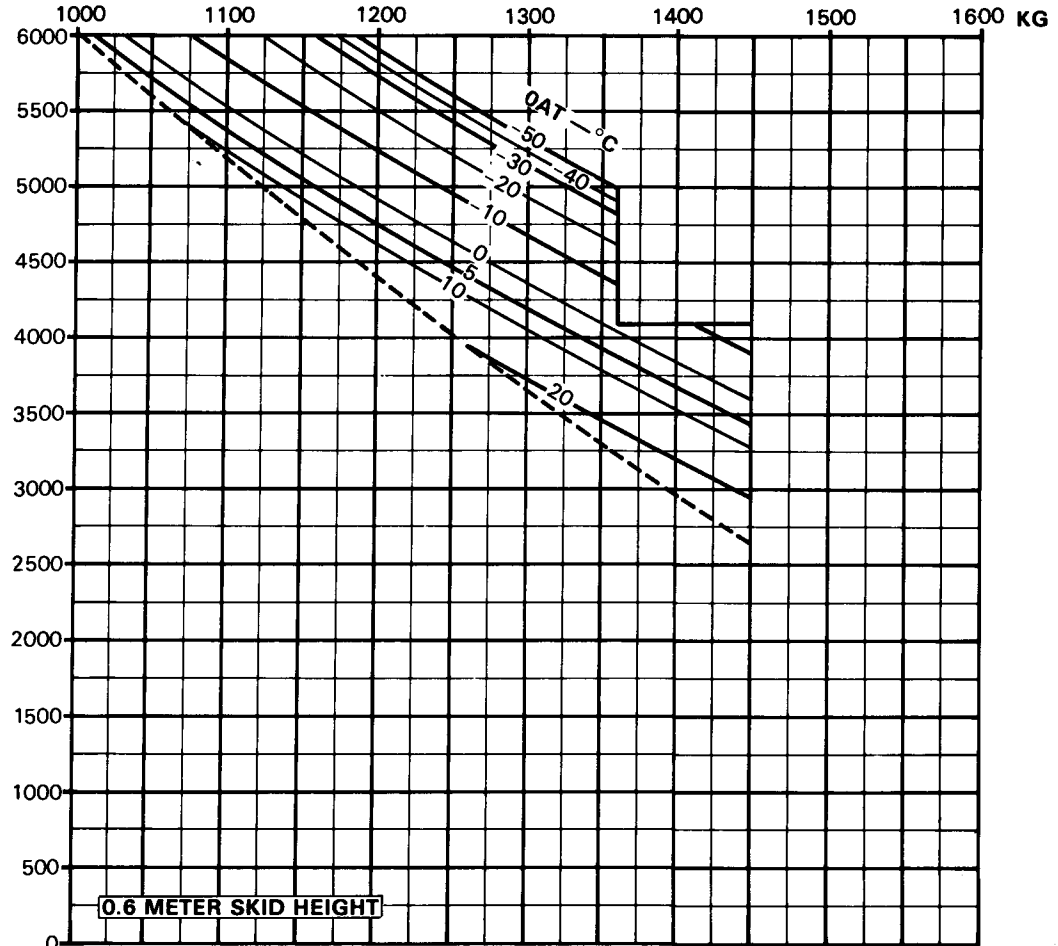

THIS IS AN UNCONTROLLED DOCUMENT. THE DATA IS PRESENTED FOR GENERAL INFORMATION ONLY. SOME INFORMATION HAS BEEN SUPERCEDED SINCE ORIGINAL PUBLICATION. PLEASE REFER TO THE CURRENT PRODUCT SPECIFICATION BOOKLET FOR UP-TO-DATE STANDARD EQUIPMENT LIST & KIT WEIGHTS, PERFORMANCE, AND DIRECT OPERATING COST.



BELL 206B JETRANGER III

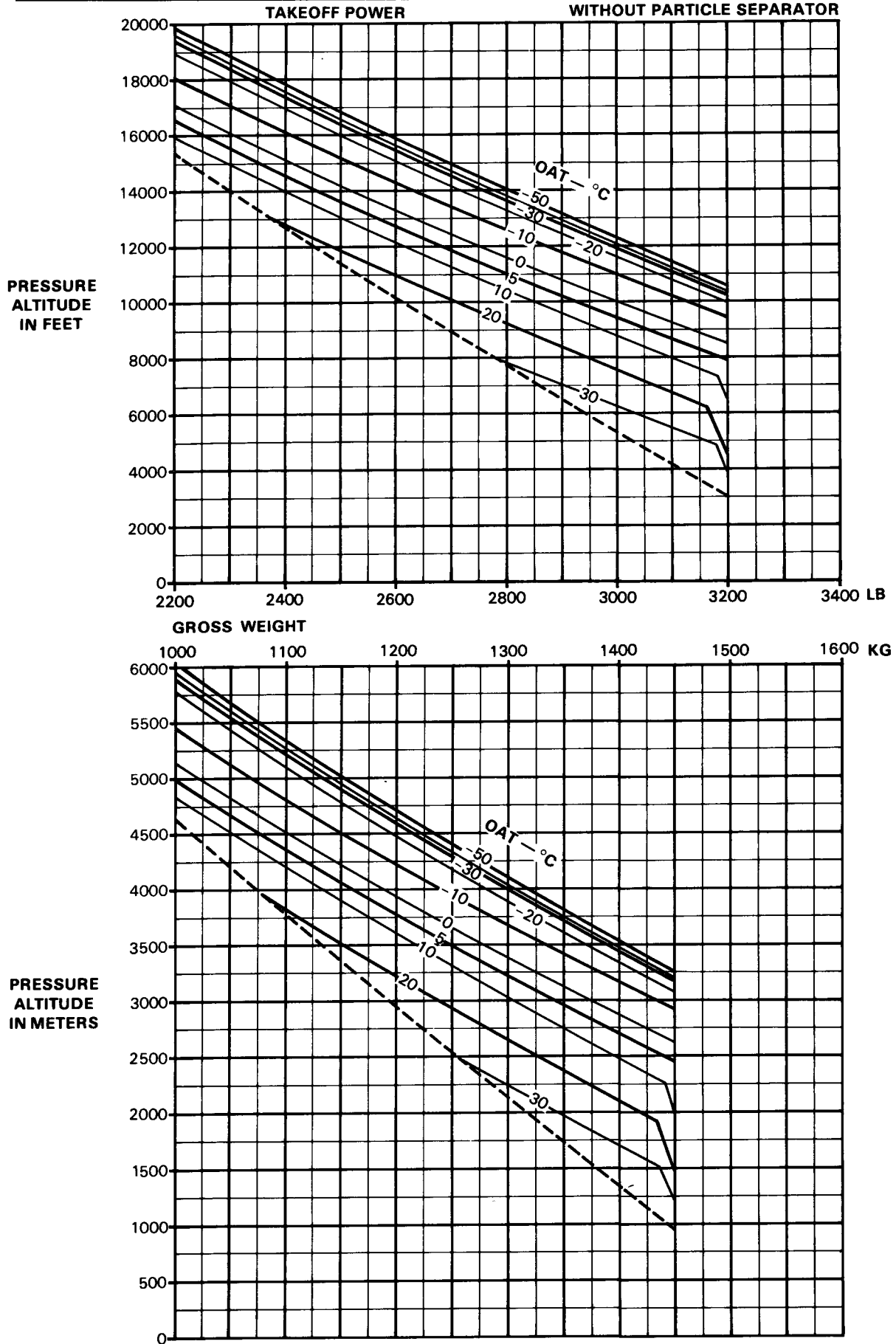

GEILING
CEILING
HOVERING
HOVERING
OGE



THIS IS AN UNCONTROLLED DOCUMENT. THE DATA IS PRESENTED FOR GENERAL INFORMATION ONLY. SOME INFORMATION HAS BEEN SUPERCEDED SINCE ORIGINAL PUBLICATION. PLEASE REFER TO THE CURRENT PRODUCT SPECIFICATION BOOKLET FOR UP-TO-DATE STANDARD EQUIPMENT LIST & KIT WEIGHTS, PERFORMANCE, AND DIRECT OPERATING COST.

BELL 206B JETRANGER III

ICE HOVERING CEILING

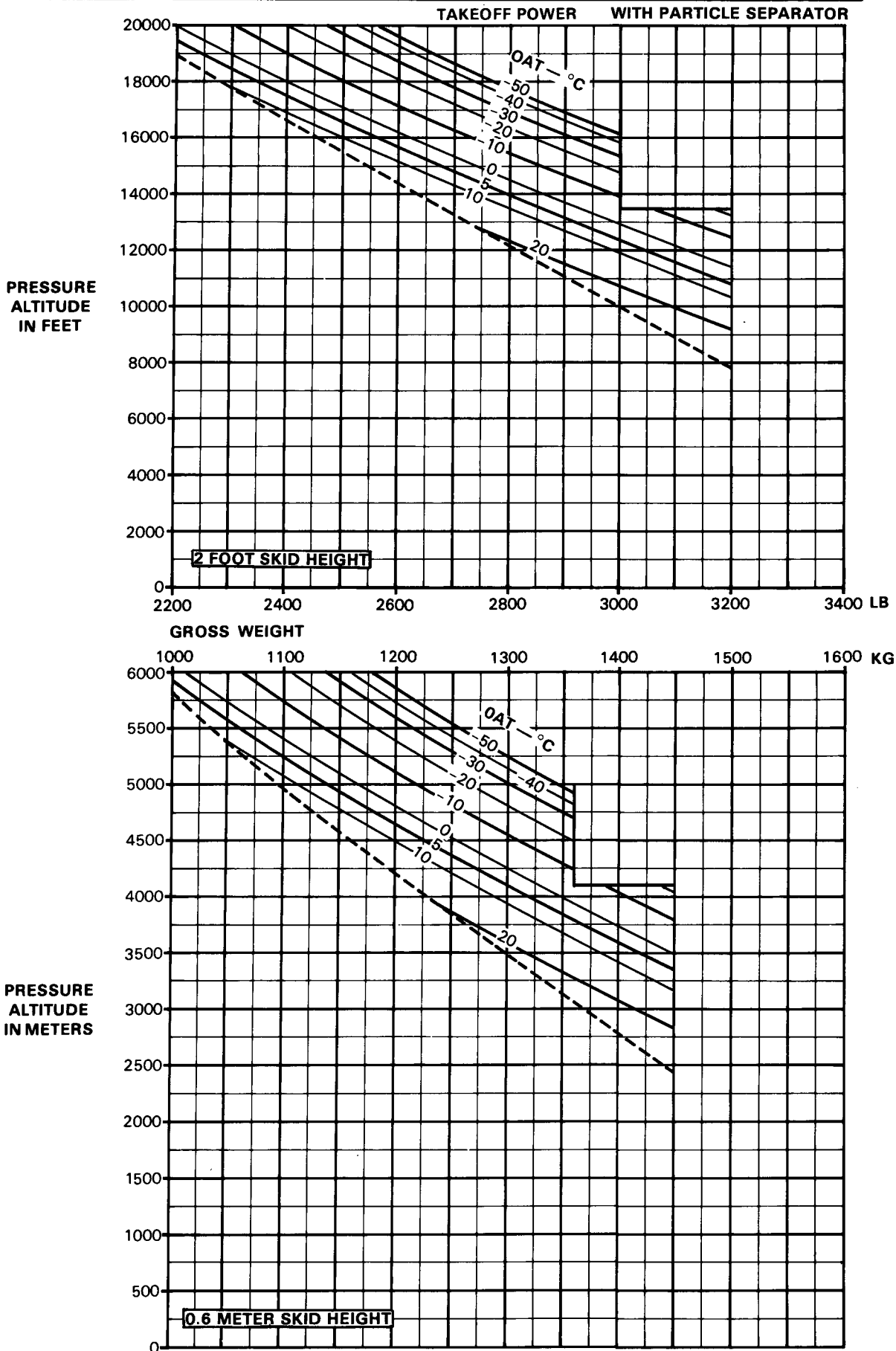

THIS IS AN UNCONTROLLED DOCUMENT. THE DATA IS PRESENTED FOR GENERAL INFORMATION ONLY. SOME INFORMATION HAS BEEN SUPERCEDED SINCE ORIGINAL PUBLICATION. PLEASE REFER TO THE CURRENT PRODUCT SPECIFICATION BOOKLET FOR UP-TO-DATE STANDARD EQUIPMENT LIST & KIT WEIGHTS, PERFORMANCE, AND DIRECT OPERATING COST.

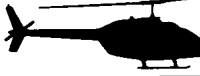

**BELL 206B
JETRANGER III**

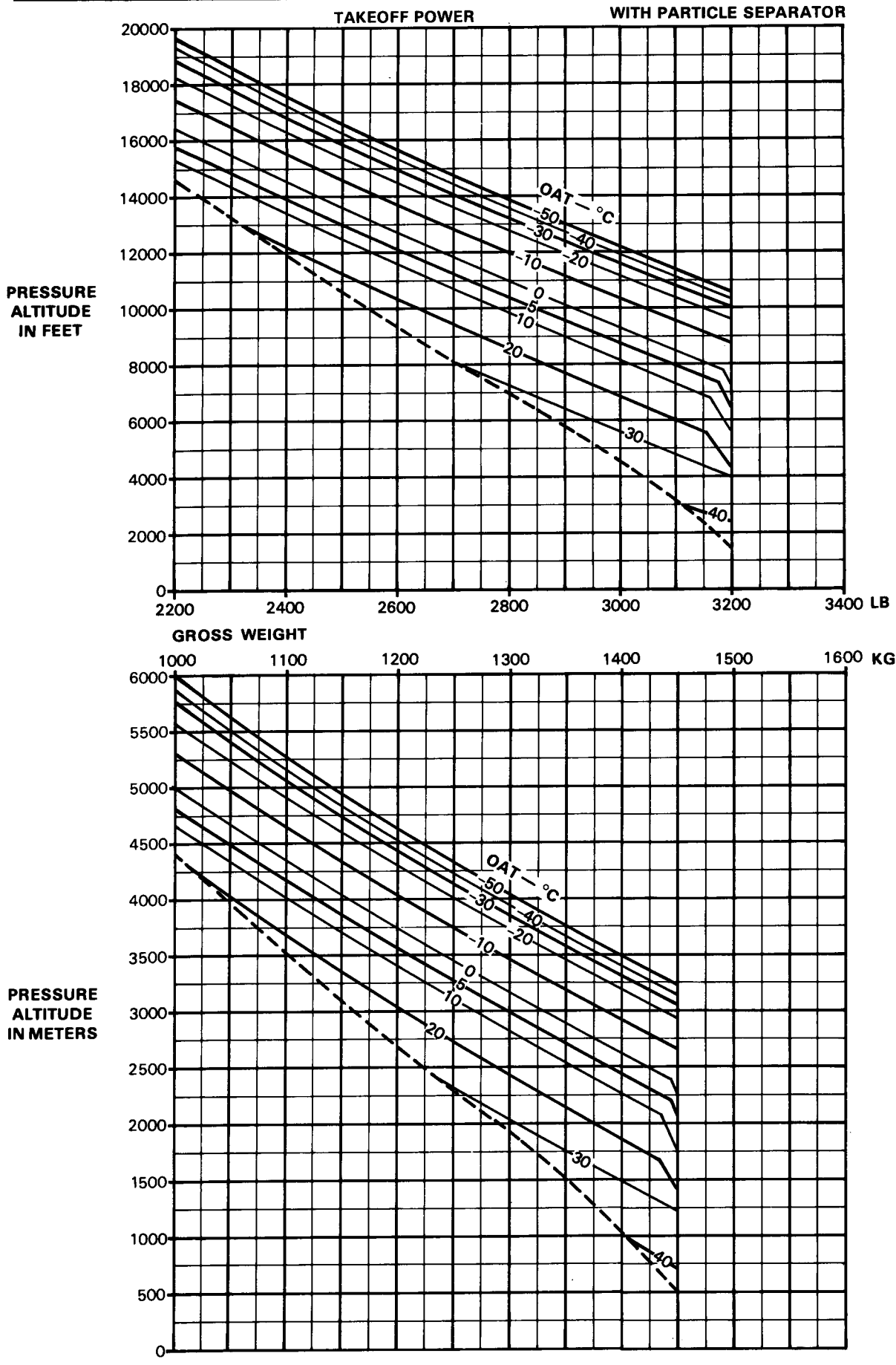

CEILING
HOVERING
HOGGE



THIS IS AN UNCONTROLLED DOCUMENT. THE DATA IS PRESENTED FOR GENERAL INFORMATION ONLY. SOME INFORMATION HAS BEEN SUPERCEDED SINCE ORIGINAL PUBLICATION. PLEASE REFER TO THE CURRENT PRODUCT SPECIFICATION BOOKLET FOR UP-TO-DATE STANDARD EQUIPMENT LIST & KIT WEIGHTS, PERFORMANCE, AND DIRECT OPERATING COST.

BELL 206B JETRANGER III

ICE HOVERING
CEILING

PRESSURE
ALTITUDE
IN FEET

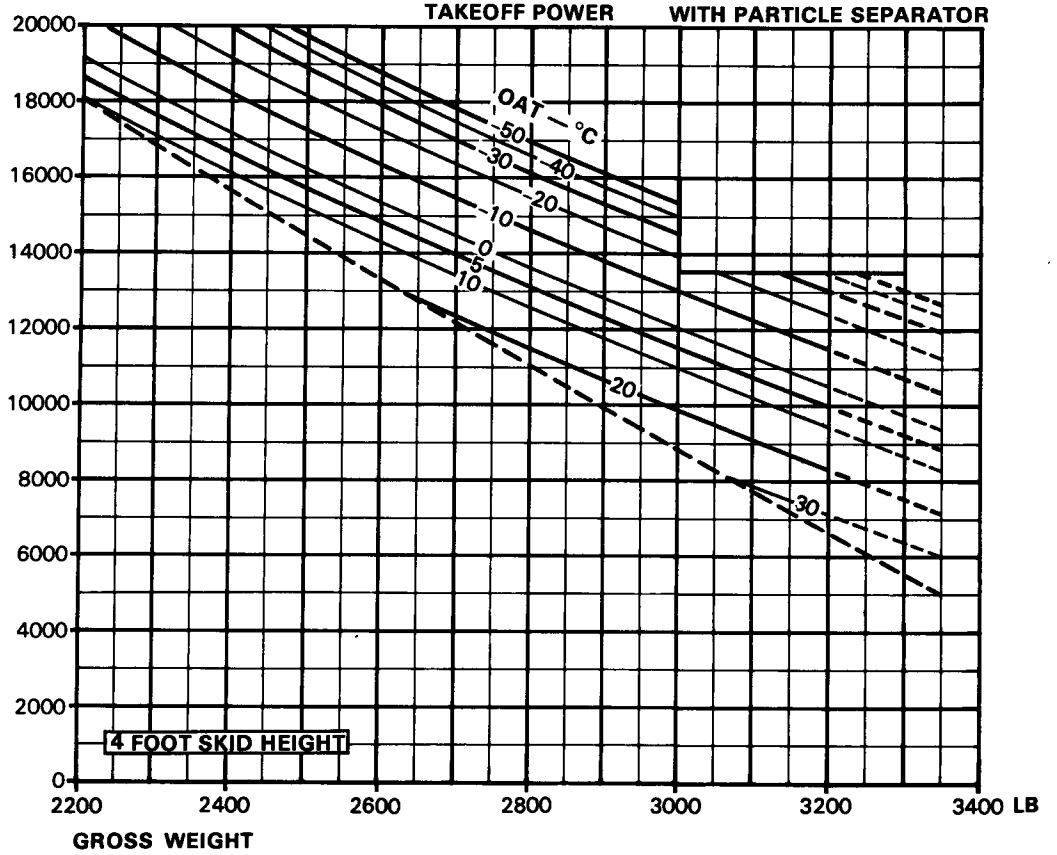

PRESSURE
ALTITUDE
IN METERS

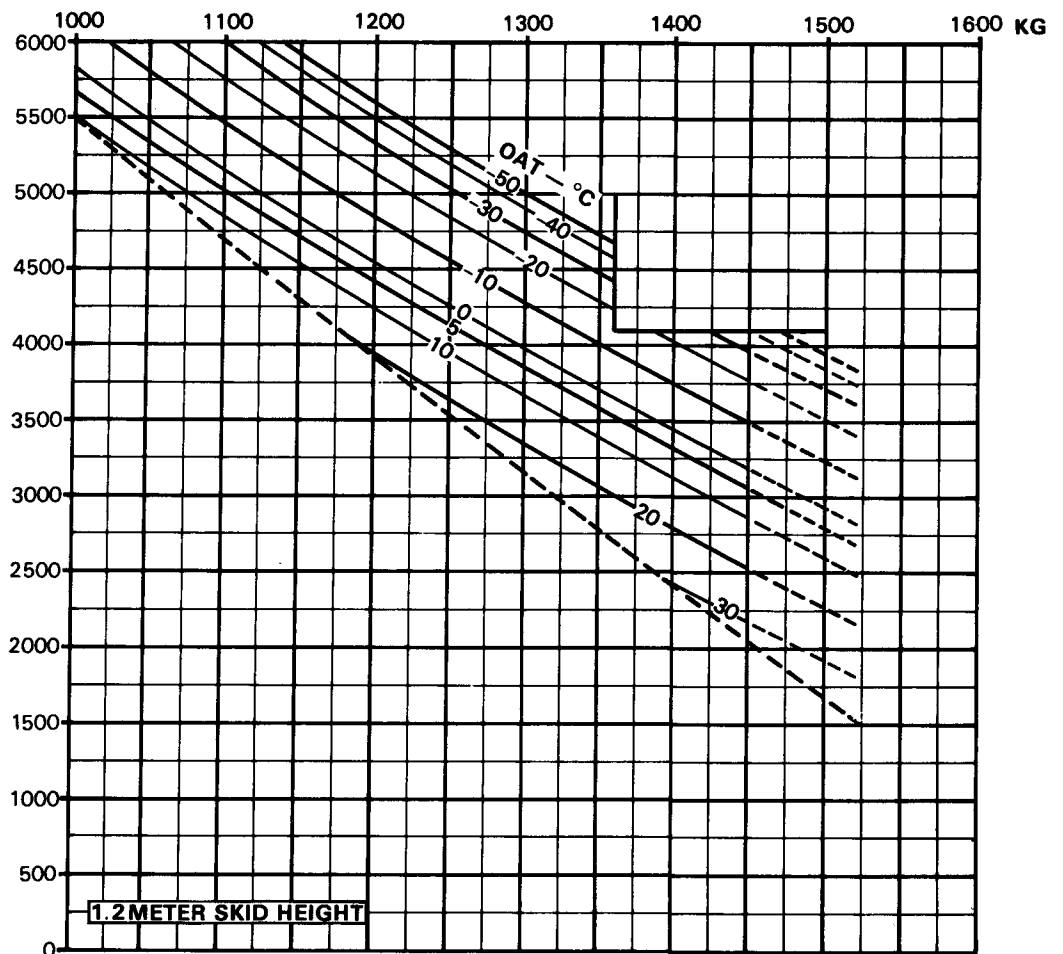



THIS IS AN UNCONTROLLED DOCUMENT. THE DATA IS PRESENTED FOR GENERAL INFORMATION ONLY. SOME INFORMATION HAS BEEN SUPERCEDED SINCE ORIGINAL PUBLICATION. PLEASE REFER TO THE CURRENT PRODUCT SPECIFICATION BOOKLET FOR UP-TO-DATE STANDARD EQUIPMENT LIST & KIT WEIGHTS, PERFORMANCE, AND DIRECT OPERATING COST.

BELL 206B JETRANGER III

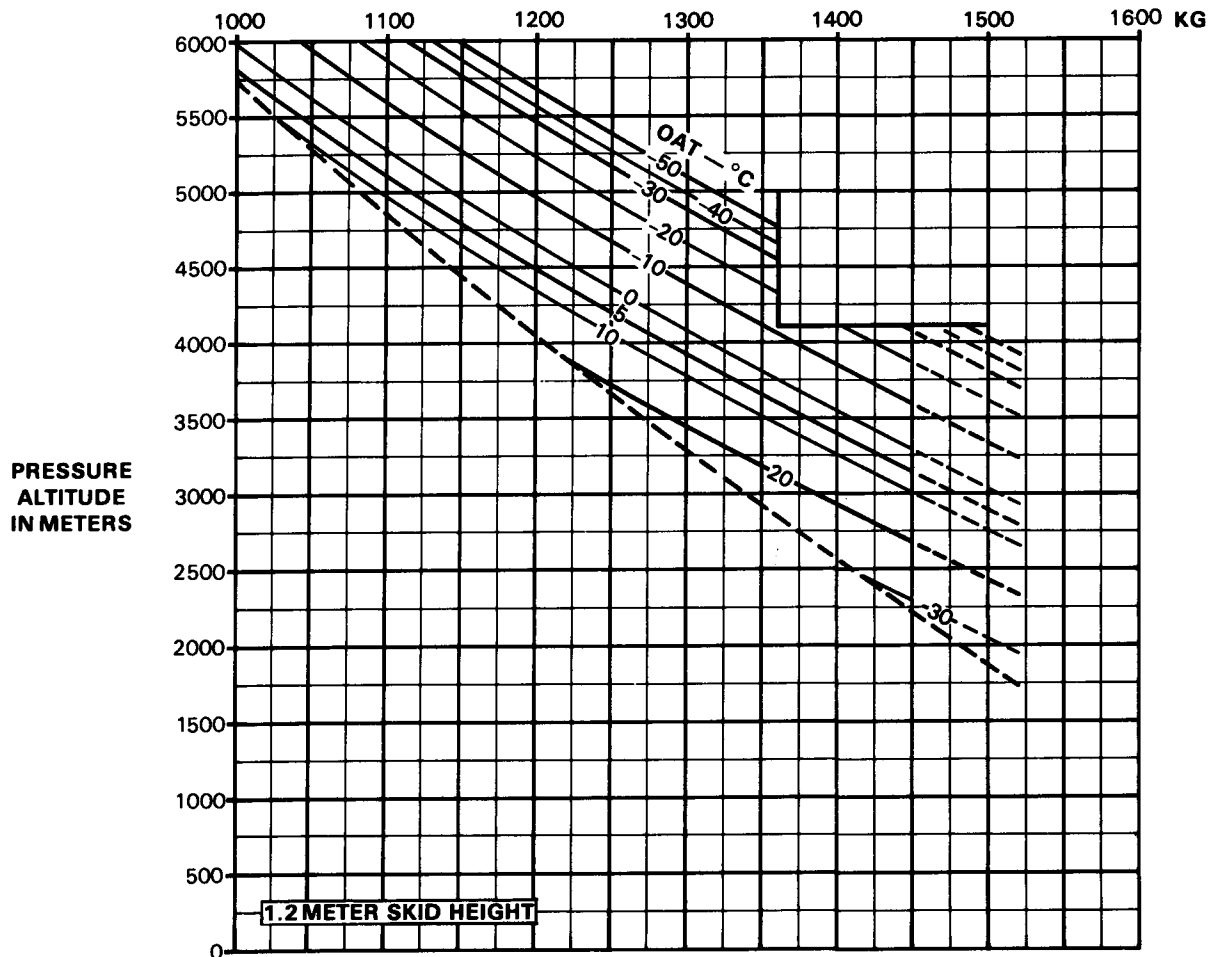
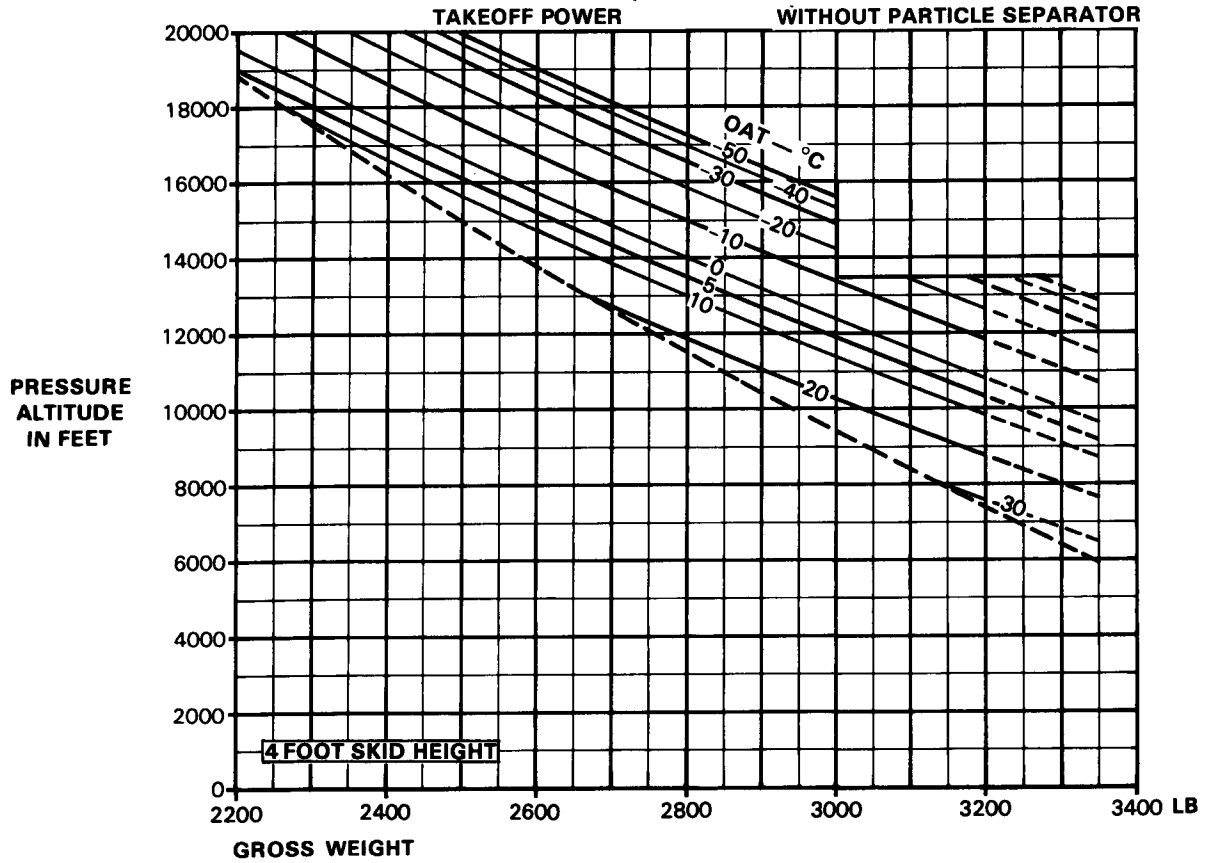

IGE HOVERING
CEILING



THIS IS AN UNCONTROLLED DOCUMENT. THE DATA IS PRESENTED FOR GENERAL INFORMATION ONLY. SOME INFORMATION HAS BEEN SUPERCEDED SINCE ORIGINAL PUBLICATION. PLEASE REFER TO THE CURRENT PRODUCT SPECIFICATION BOOKLET FOR UP-TO-DATE STANDARD EQUIPMENT LIST & KIT WEIGHTS, PERFORMANCE, AND DIRECT OPERATING COST.

BELL 206B JETRANGER III

CEILING SERVICE

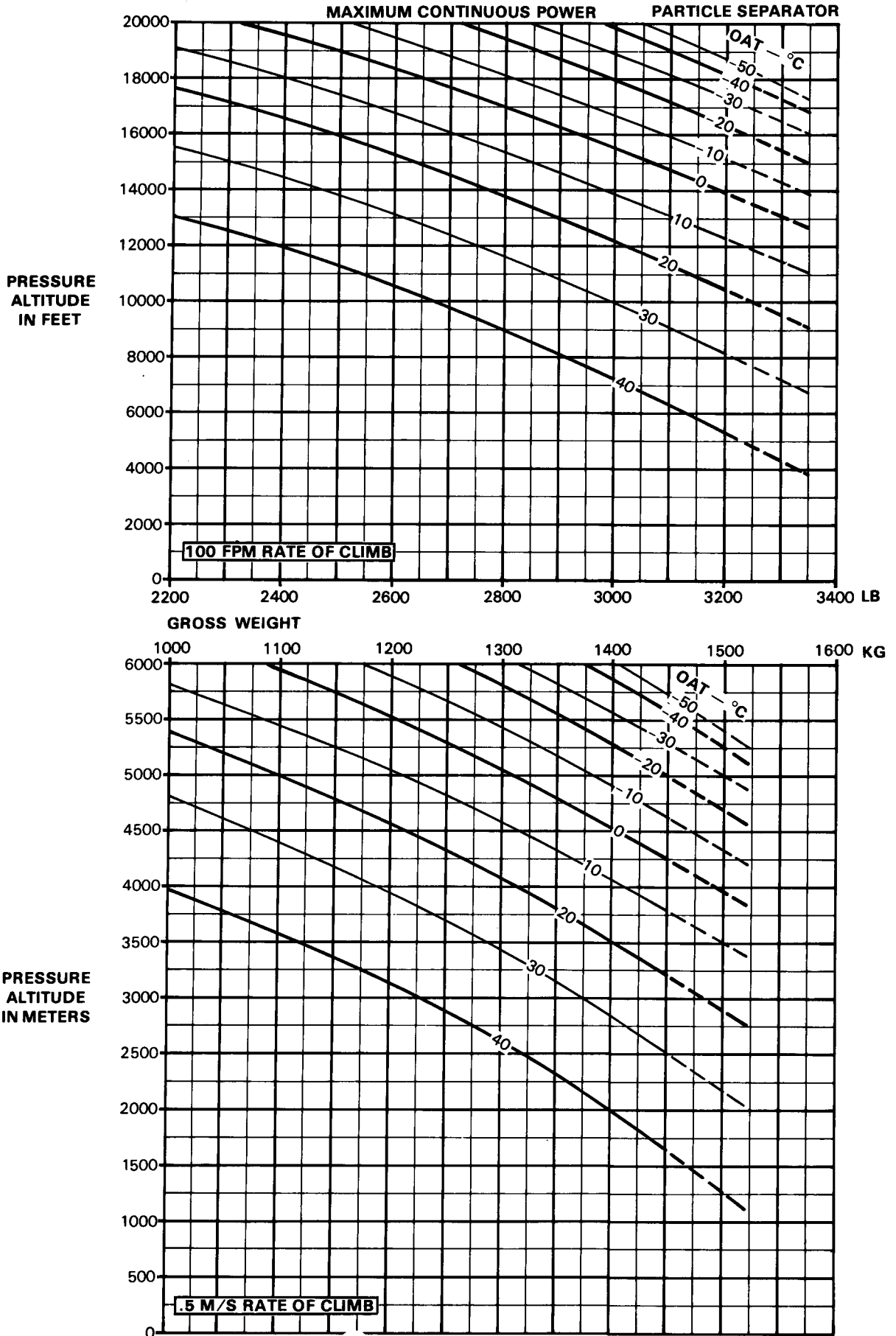



THIS IS AN UNCONTROLLED DOCUMENT. THE DATA IS PRESENTED FOR GENERAL INFORMATION ONLY. SOME INFORMATION HAS BEEN SUPERCEDED SINCE ORIGINAL PUBLICATION. PLEASE REFER TO THE CURRENT PRODUCT SPECIFICATION BOOKLET FOR UP-TO-DATE STANDARD EQUIPMENT LIST & KIT WEIGHTS, PERFORMANCE, AND DIRECT OPERATING COST.

BELL 206B JETRANGER III

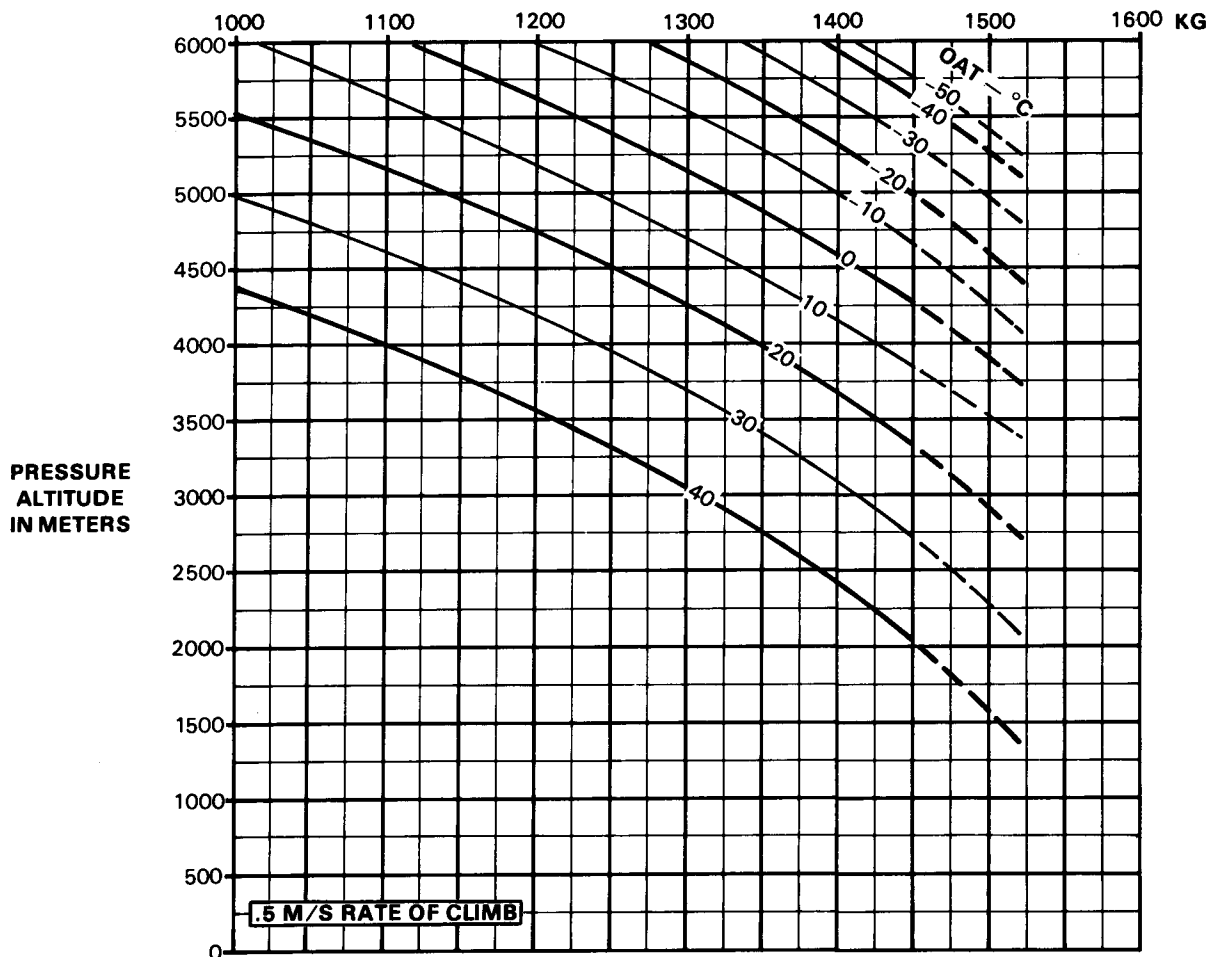
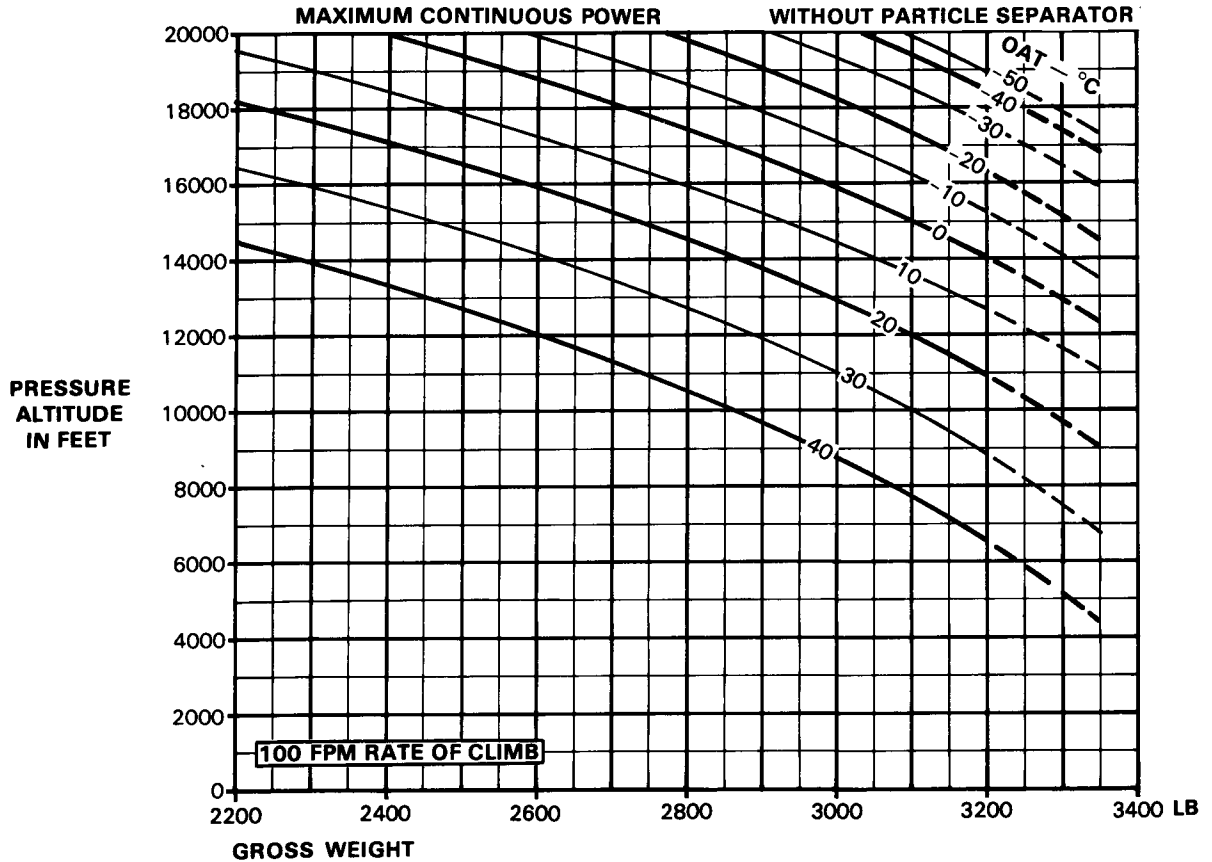

G
E
L
L
I
N
G

C
E
L
L
I
N
G

S
E
R
V
I
C
E



THIS IS AN UNCONTROLLED DOCUMENT. THE DATA IS PRESENTED FOR GENERAL INFORMATION ONLY. SOME INFORMATION HAS BEEN SUPERCEDED SINCE ORIGINAL PUBLICATION. PLEASE REFER TO THE CURRENT PRODUCT SPECIFICATION BOOKLET FOR UP-TO-DATE STANDARD EQUIPMENT LIST & KIT WEIGHTS, PERFORMANCE, AND DIRECT OPERATING COST.

BELL 206B JETRANGER III

CLIMB RATE OF

PRESSURE ALTITUDE IN FEET

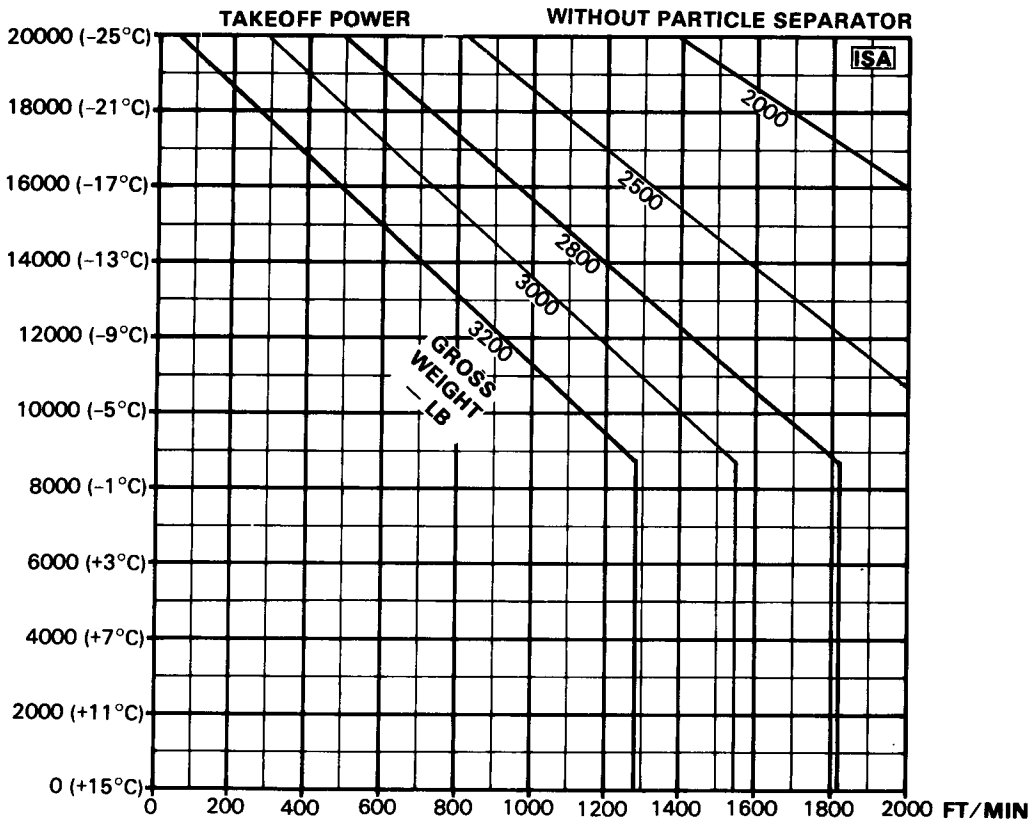

PRESSURE ALTITUDE IN METERS

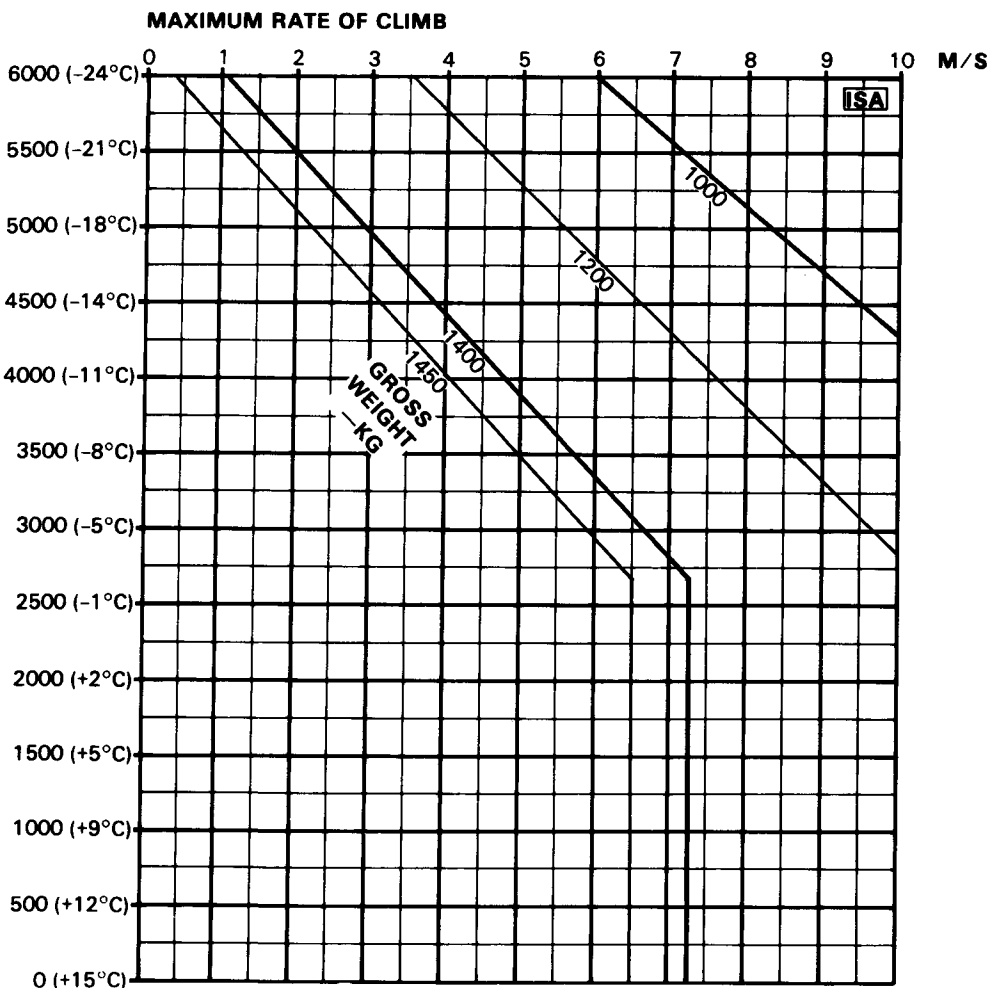

THIS IS AN UNCONTROLLED DOCUMENT. THE DATA IS PRESENTED FOR GENERAL INFORMATION ONLY. SOME INFORMATION HAS BEEN SUPERCEDED SINCE ORIGINAL PUBLICATION. PLEASE REFER TO THE CURRENT PRODUCT SPECIFICATION BOOKLET FOR UP-TO-DATE STANDARD EQUIPMENT LIST & KIT WEIGHTS, PERFORMANCE, AND DIRECT OPERATING COST.



**BELL 206B
JETRANGER III**

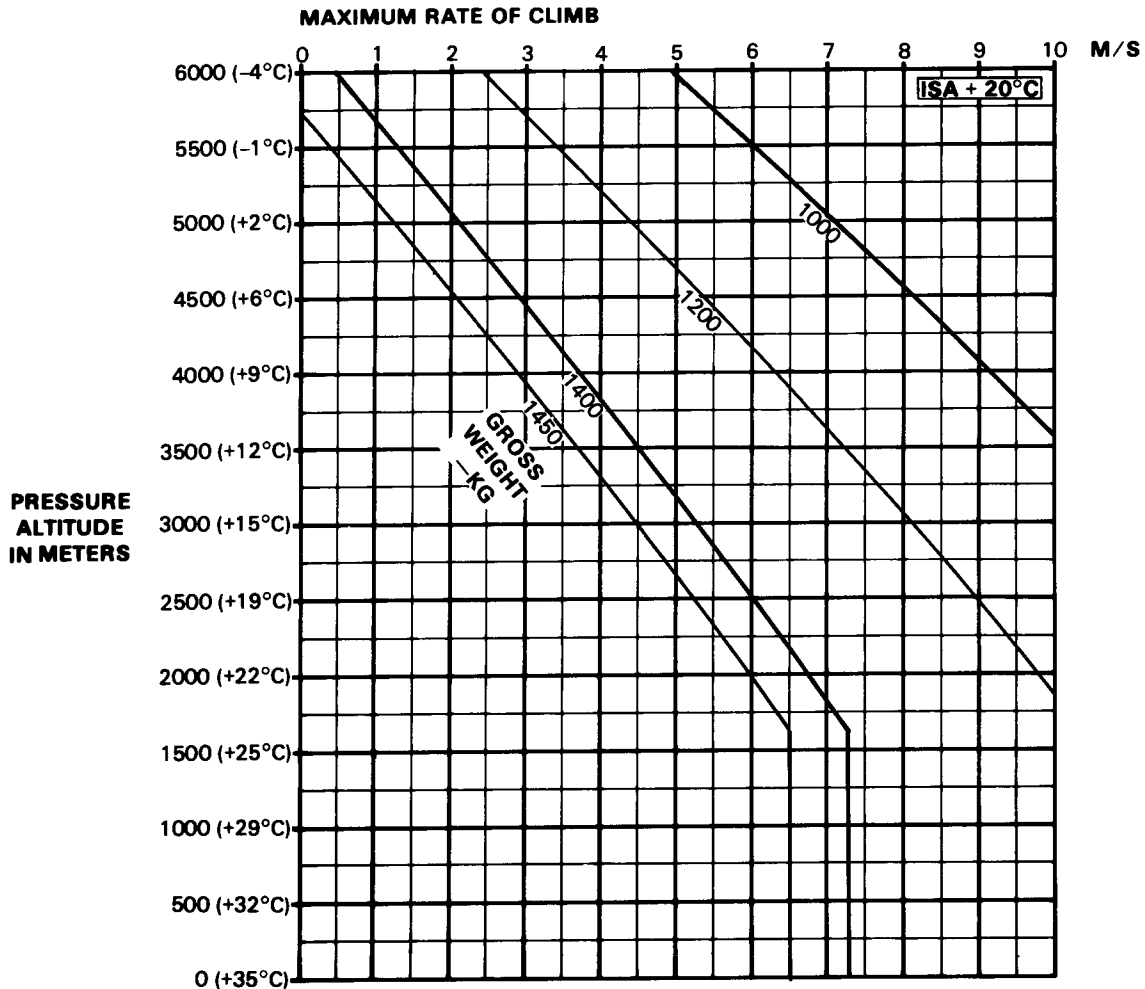
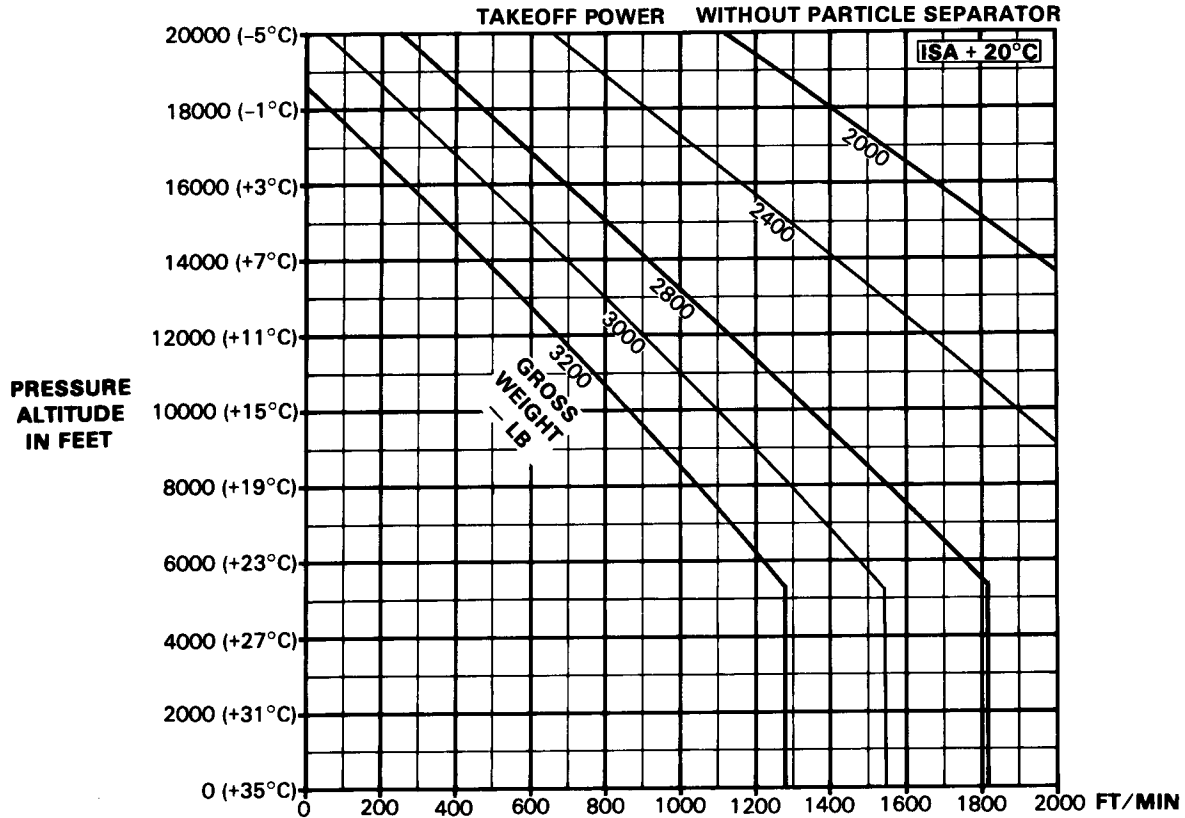

**B
L
I
M
C
L
I
M
B
O
F
C
L
I
M
B
O
F
C
L
I
M
B
O
F
C
L
I
M
B**



THIS IS AN UNCONTROLLED DOCUMENT. THE DATA IS PRESENTED FOR GENERAL INFORMATION ONLY. SOME INFORMATION HAS BEEN SUPERCEDED SINCE ORIGINAL PUBLICATION. PLEASE REFER TO THE CURRENT PRODUCT SPECIFICATION BOOKLET FOR UP-TO-DATE STANDARD EQUIPMENT LIST & KIT WEIGHTS, PERFORMANCE, AND DIRECT OPERATING COST.

BELL 206B JETRANGER III

CLIMB RATE OF B

PRESSURE
ALTITUDE
IN FEET

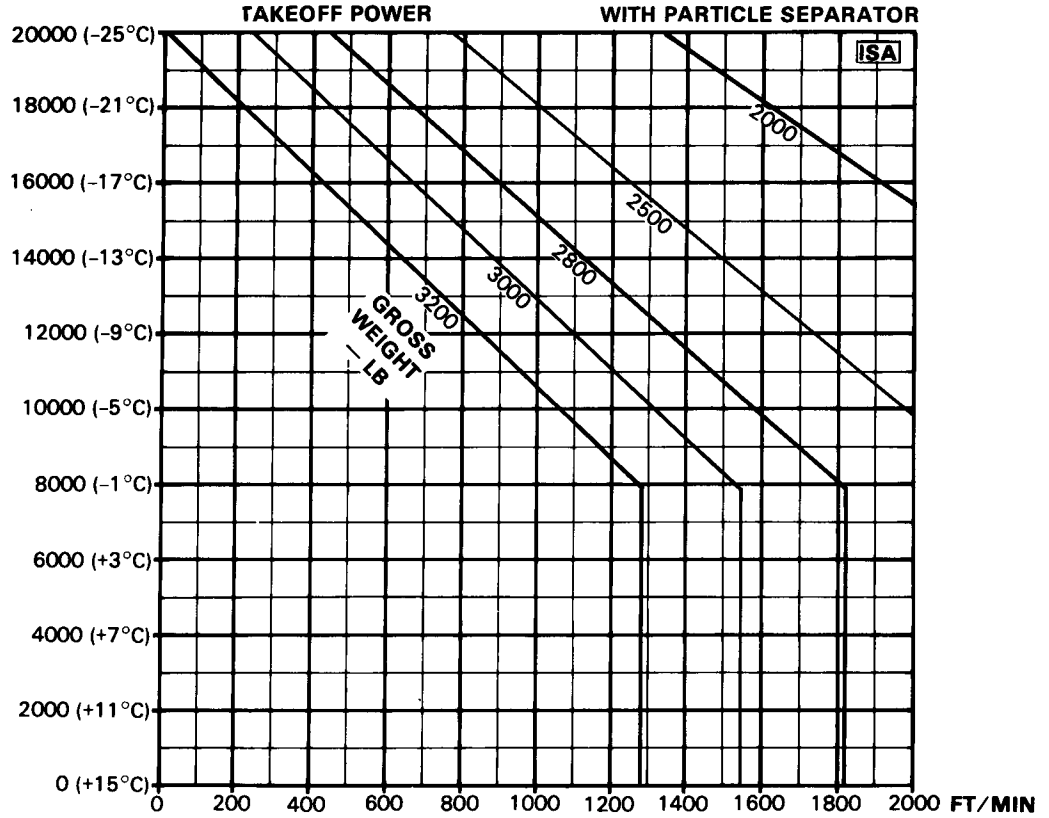

PRESSURE
ATTITUDE
IN METERS

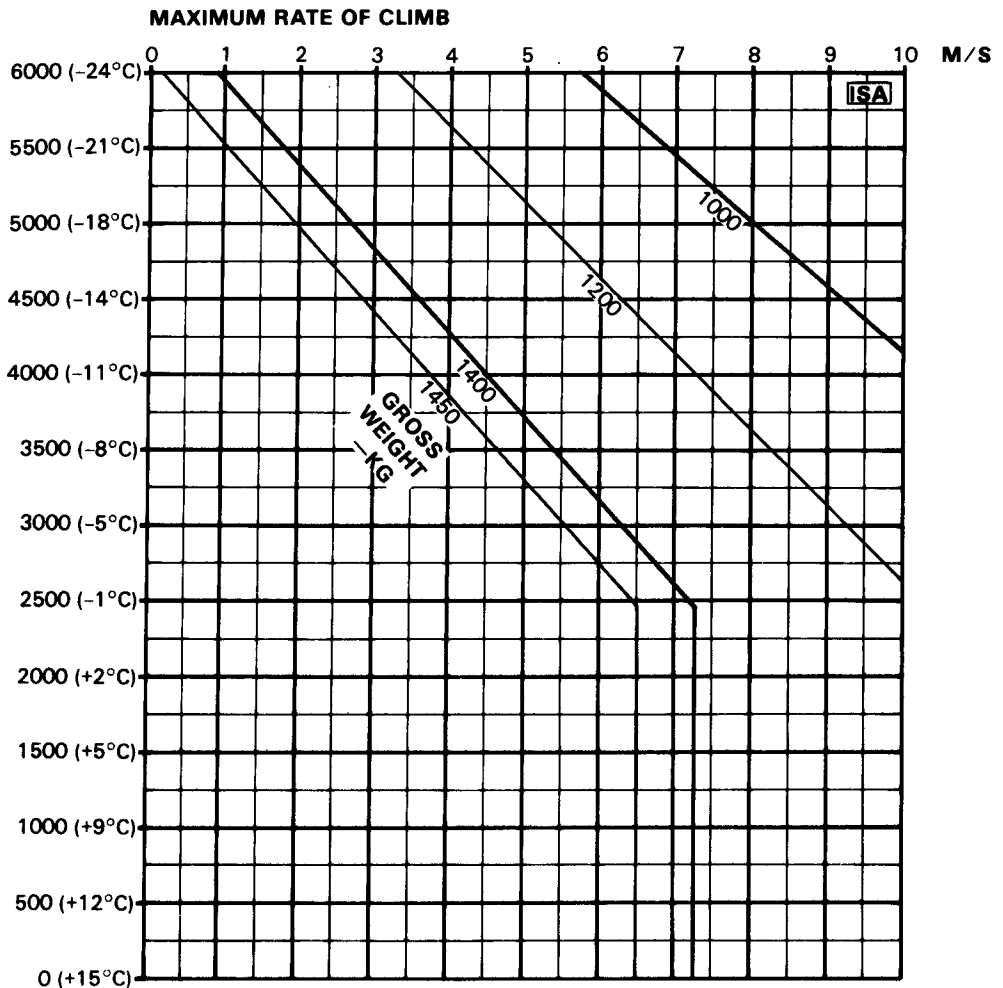



THIS IS AN UNCONTROLLED DOCUMENT. THE DATA IS PRESENTED FOR GENERAL INFORMATION ONLY. SOME INFORMATION HAS BEEN SUPERCEDED SINCE ORIGINAL PUBLICATION. PLEASE REFER TO THE CURRENT PRODUCT SPECIFICATION BOOKLET FOR UP-TO-DATE STANDARD EQUIPMENT LIST & KIT WEIGHTS, PERFORMANCE, AND DIRECT OPERATING COST.

BELL 206B JETRANGER III

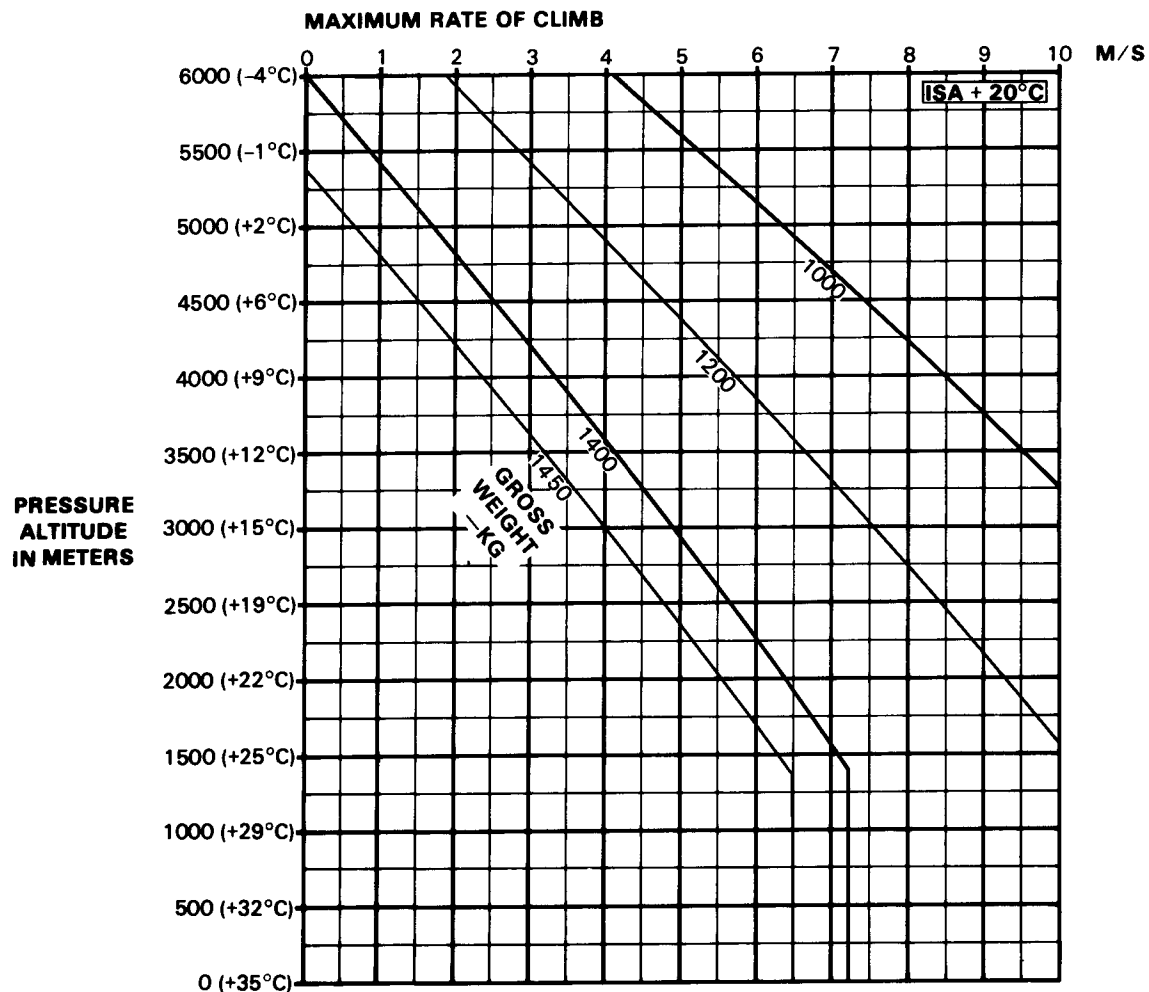
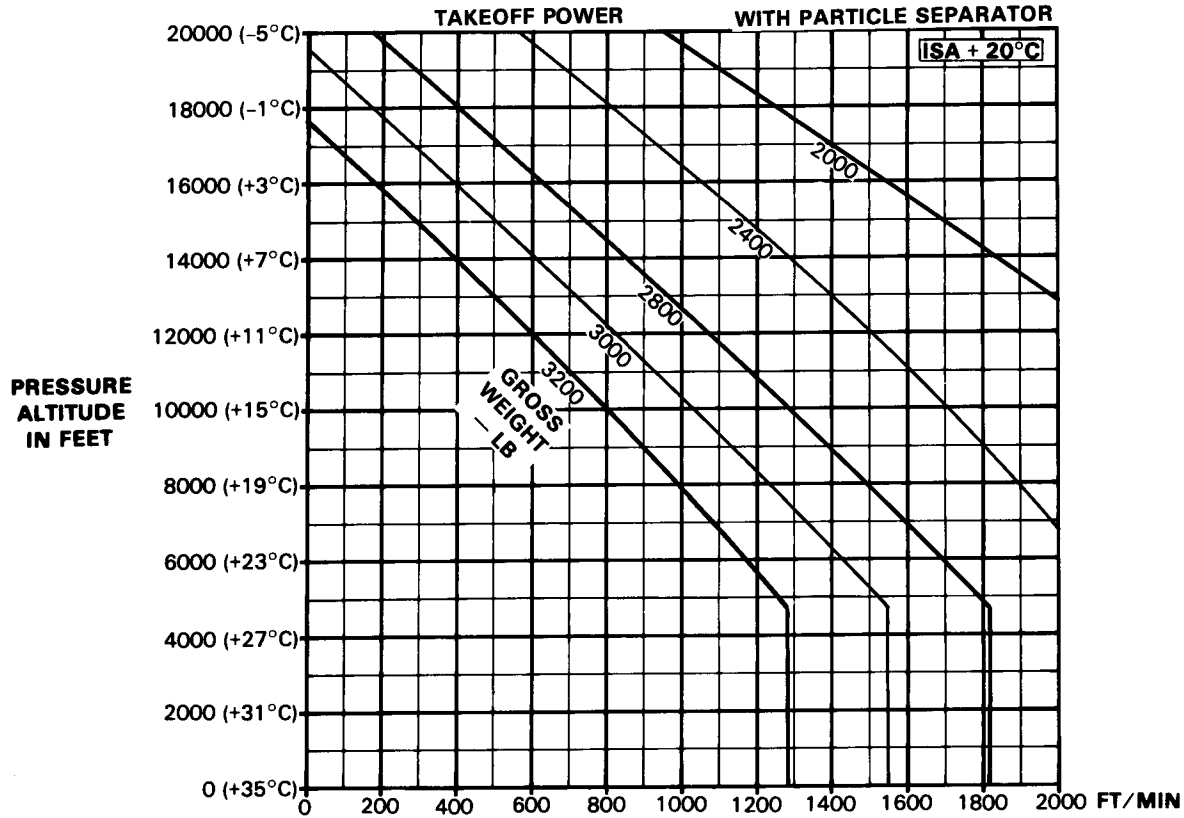

B
L
L
C
L
I
M
B

O
F

R
A
T
E
O
F
C
L
I
M
B



THIS IS AN UNCONTROLLED DOCUMENT. THE DATA IS PRESENTED FOR GENERAL INFORMATION ONLY. SOME INFORMATION HAS BEEN SUPERCEDED SINCE ORIGINAL PUBLICATION. PLEASE REFER TO THE CURRENT PRODUCT SPECIFICATION BOOKLET FOR UP-TO-DATE STANDARD EQUIPMENT LIST & KIT WEIGHTS, PERFORMANCE, AND DIRECT OPERATING COST.

BELL 206B JETRANGER III

CRUISE PRESSURE ALTITUDE — SEA LEVEL TO 2000 FEET CLEAN CONFIGURATION 100% RPM JP-4 FUEL

OAT COLDER THAN -20°C

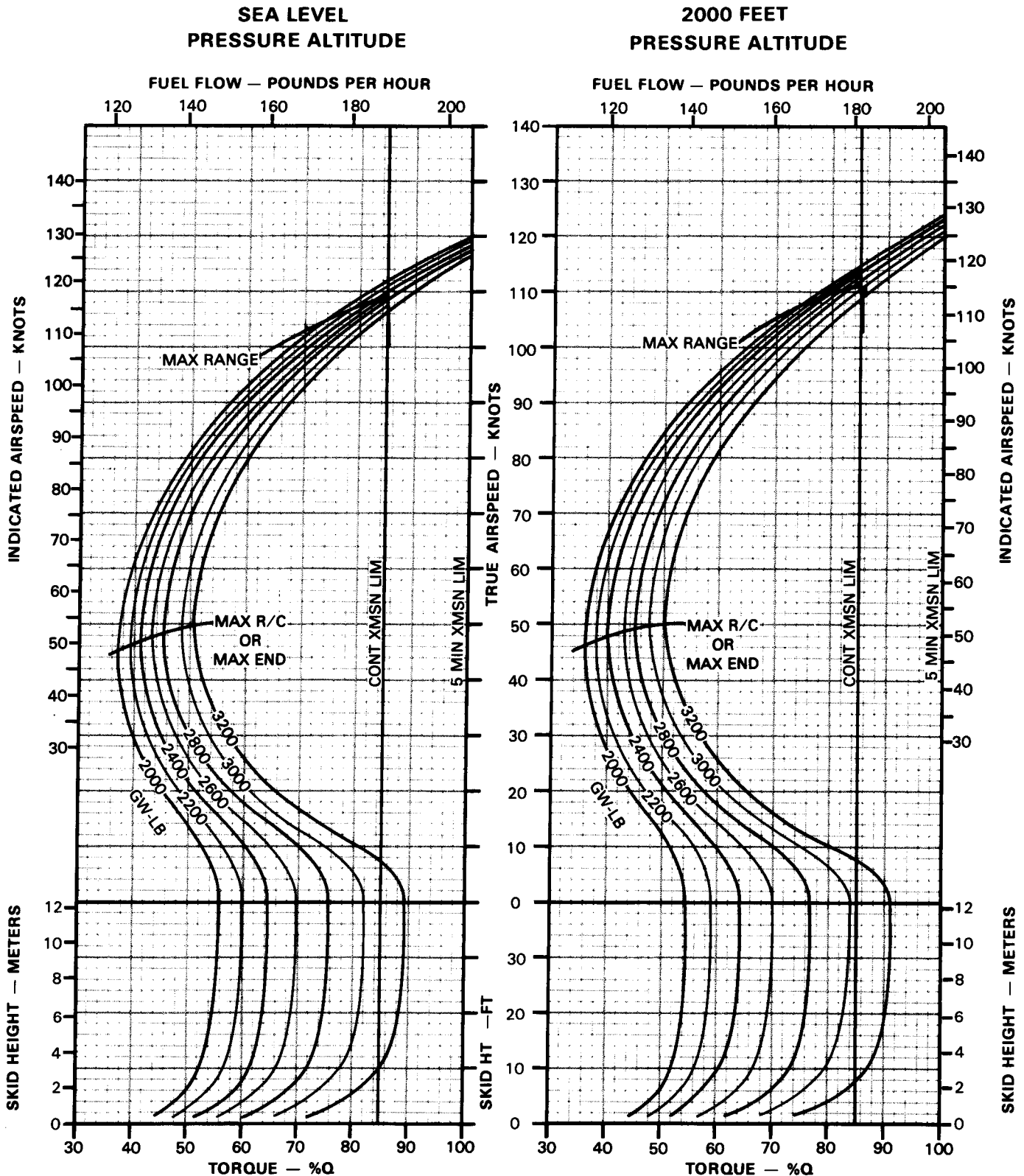



CRUISE

PRESSURE ALTITUDE — 4000 TO 6000 FEET

CLEAN CONFIGURATION 100% RPM JP-4 FUEL

OAT COLDER THAN -20°C

4000 FEET
PRESSURE ALTITUDE

6000 FEET
PRESSURE ALTITUDE

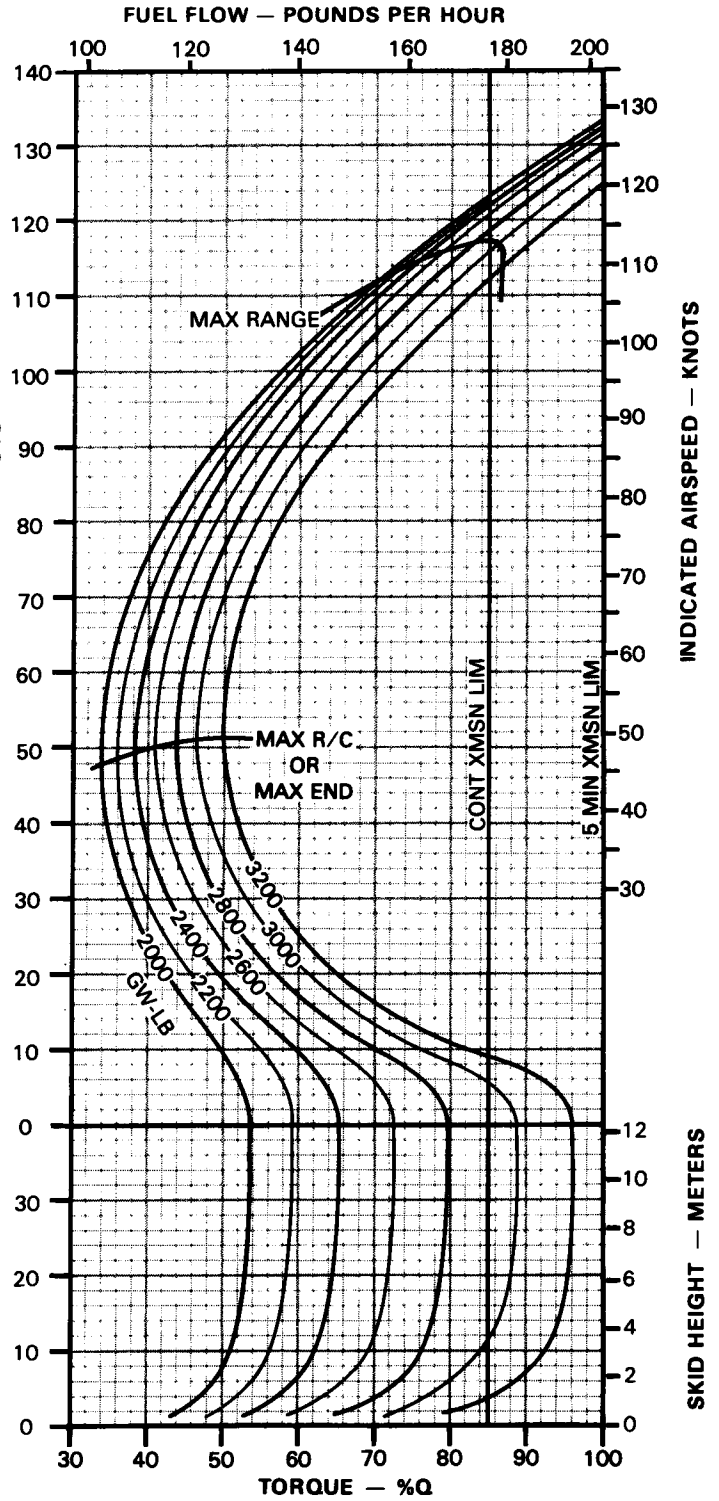
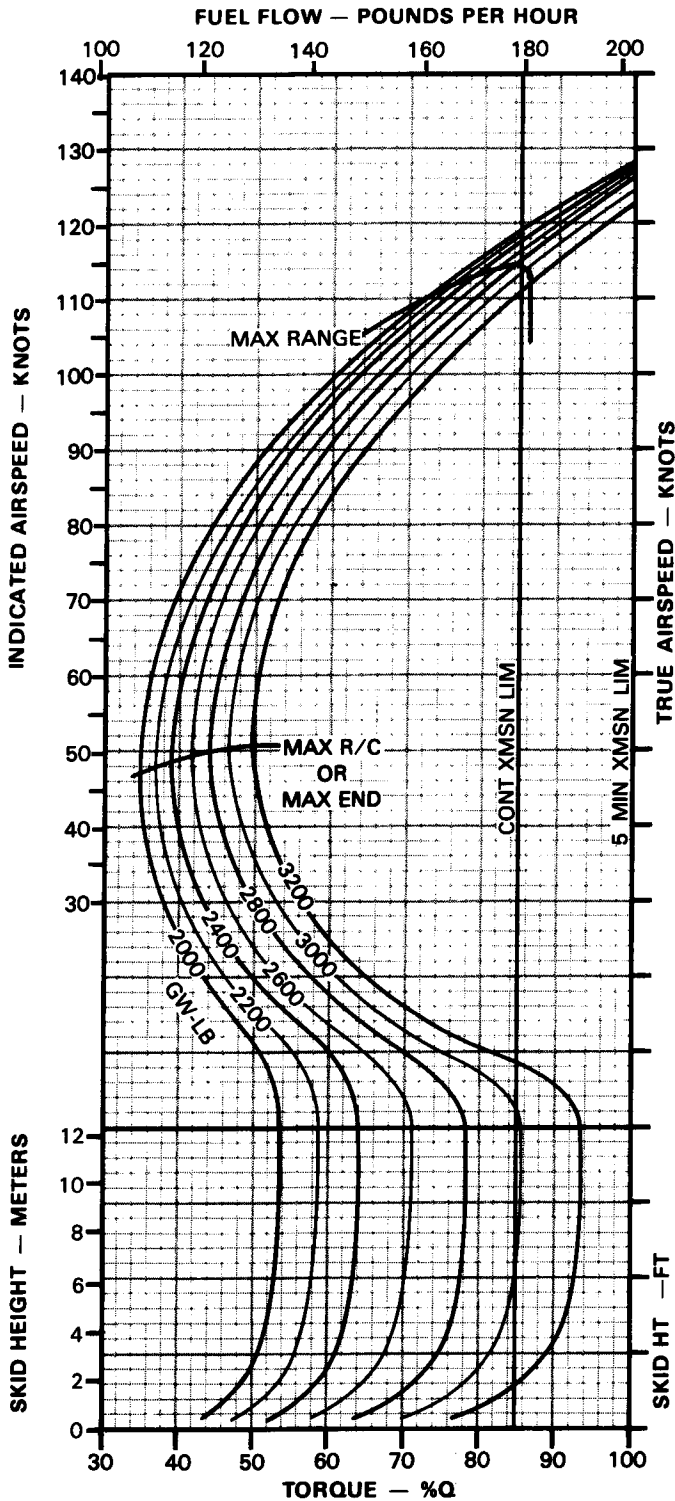



THIS IS AN UNCONTROLLED DOCUMENT. THE DATA IS PRESENTED FOR GENERAL INFORMATION ONLY. SOME INFORMATION HAS BEEN SUPERCEDED SINCE ORIGINAL PUBLICATION. PLEASE REFER TO THE CURRENT PRODUCT SPECIFICATION BOOKLET FOR UP-TO-DATE STANDARD EQUIPMENT LIST & KIT WEIGHTS, PERFORMANCE, AND DIRECT OPERATING COST.

BELL 206B
JETRANGER III

CRUISE

PRESSURE ALTITUDE — 8000 TO 10000 FEET

CLEAN CONFIGURATION 100% RPM JP-4 FUEL

OAT COLDER THAN -20°C

**8000 FEET
PRESSURE ALTITUDE**

**10000 FEET
PRESSURE ALTITUDE**

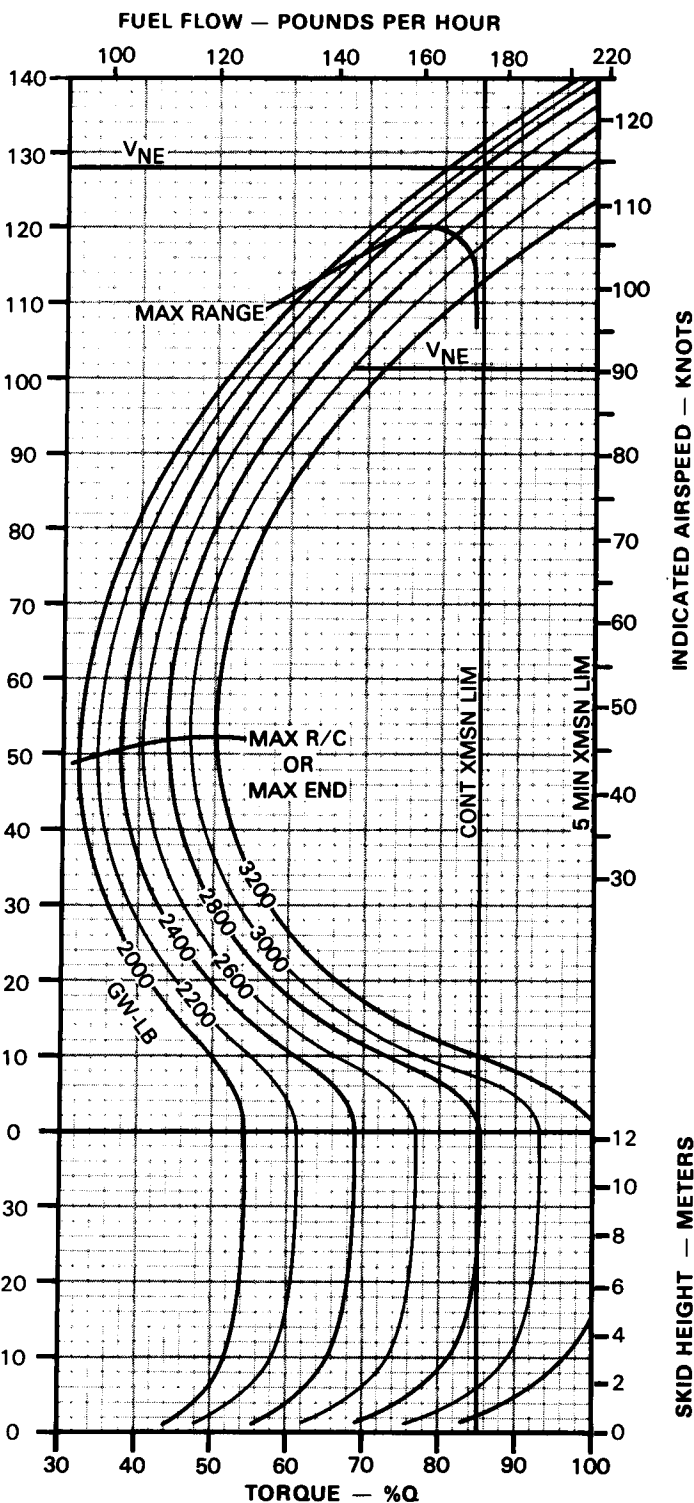
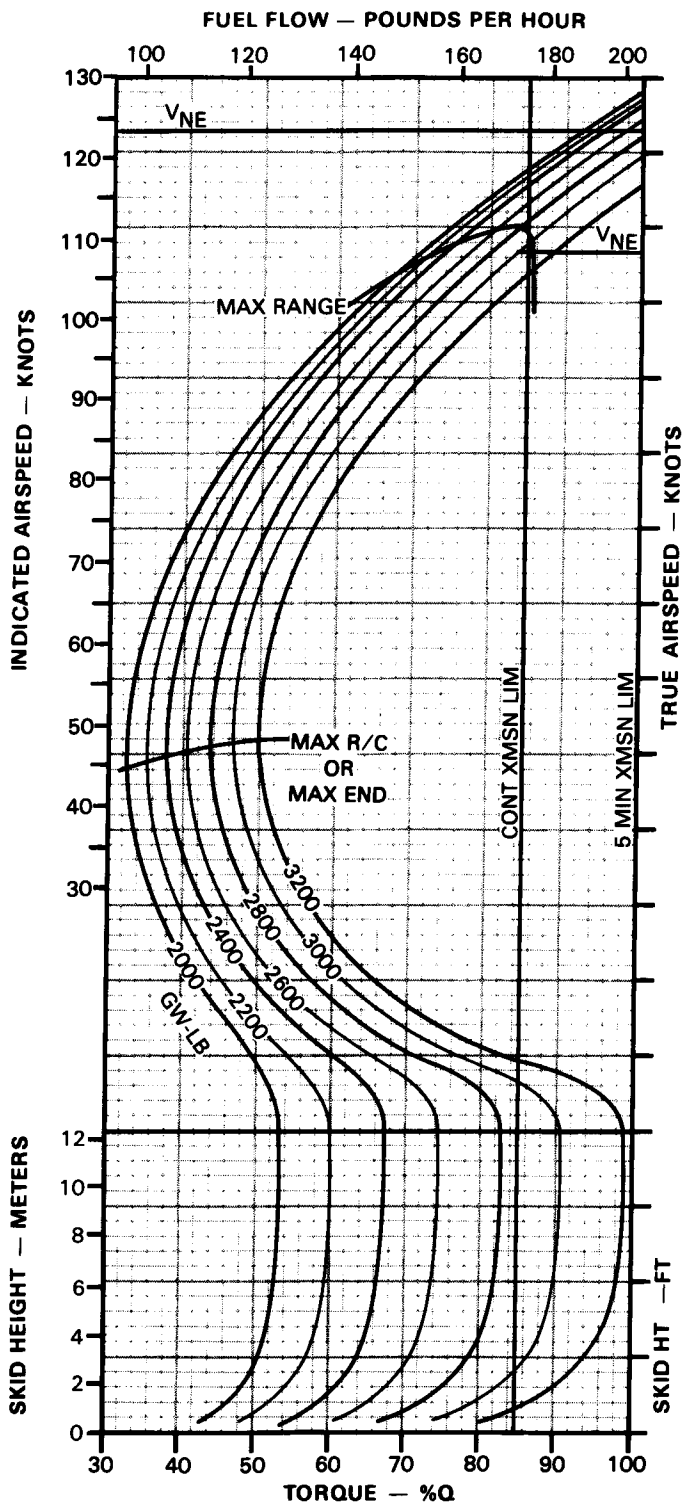



THIS IS AN UNCONTROLLED DOCUMENT. THE DATA IS PRESENTED FOR GENERAL INFORMATION ONLY. SOME INFORMATION HAS BEEN SUPERCEDED SINCE ORIGINAL PUBLICATION. PLEASE REFER TO THE CURRENT PRODUCT SPECIFICATION BOOKLET FOR UP-TO-DATE STANDARD EQUIPMENT LIST & KIT WEIGHTS, PERFORMANCE, AND DIRECT OPERATING COST.

BELL 206B JETRANGER III

CRUISE PRESSURE ALTITUDE — 12000 TO 14000 FEET CLEAN CONFIGURATION 100% RPM JP-4 FUEL

OAT COLDER THAN -20°C

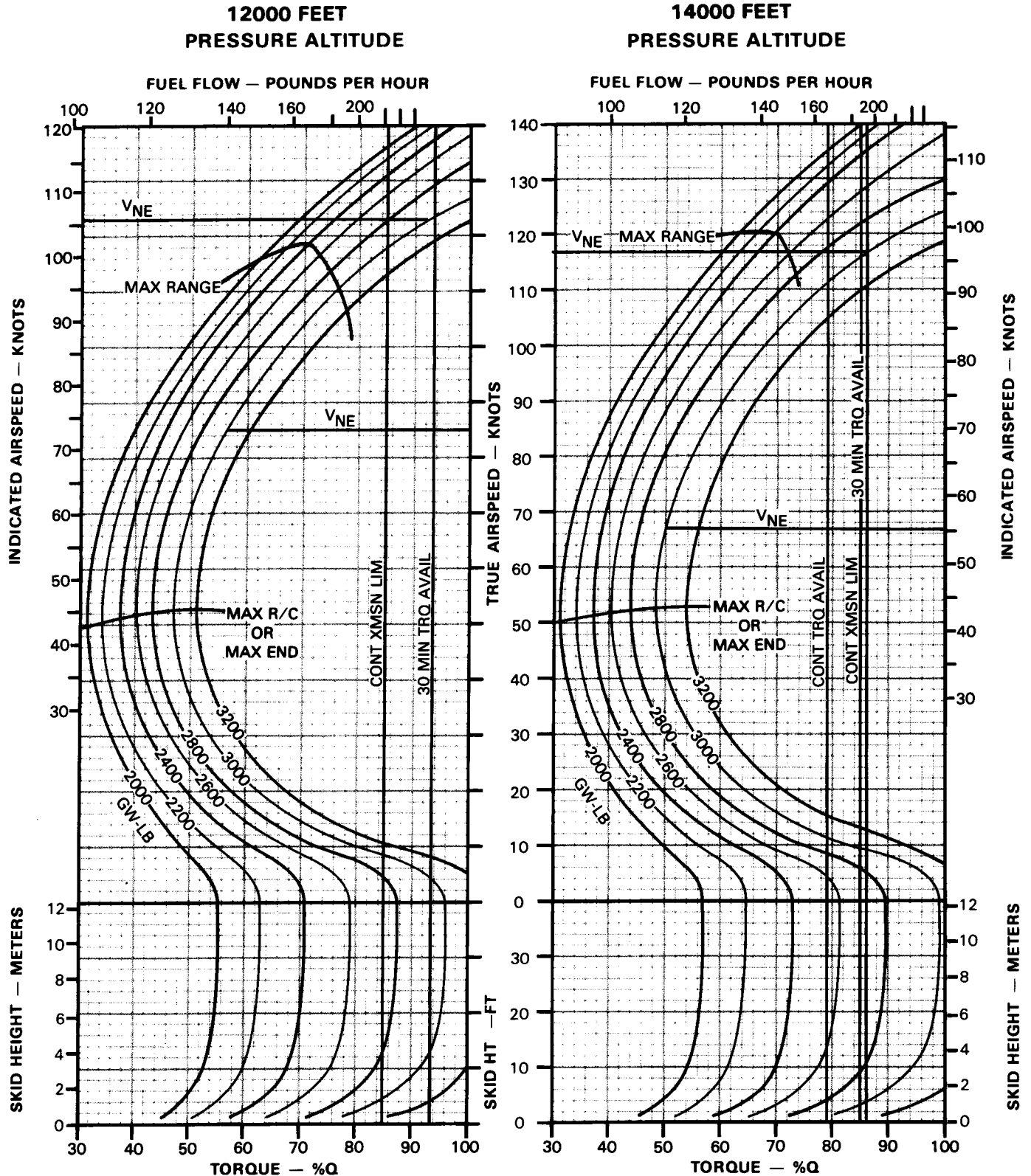



THIS IS AN UNCONTROLLED DOCUMENT. THE DATA IS PRESENTED FOR GENERAL INFORMATION ONLY. SOME INFORMATION HAS BEEN SUPERCEDED SINCE ORIGINAL PUBLICATION. PLEASE REFER TO THE CURRENT PRODUCT SPECIFICATION BOOKLET FOR UP-TO-DATE STANDARD EQUIPMENT LIST & KIT WEIGHTS, PERFORMANCE, AND DIRECT OPERATING COST.

BELL 206B JETRANGER III

CRUISE PRESSURE ALTITUDE — SEA LEVEL TO 2000 FEET CLEAN CONFIGURATION 100% RPM JP-4 FUEL

OAT BETWEEN -20°C AND -5°C

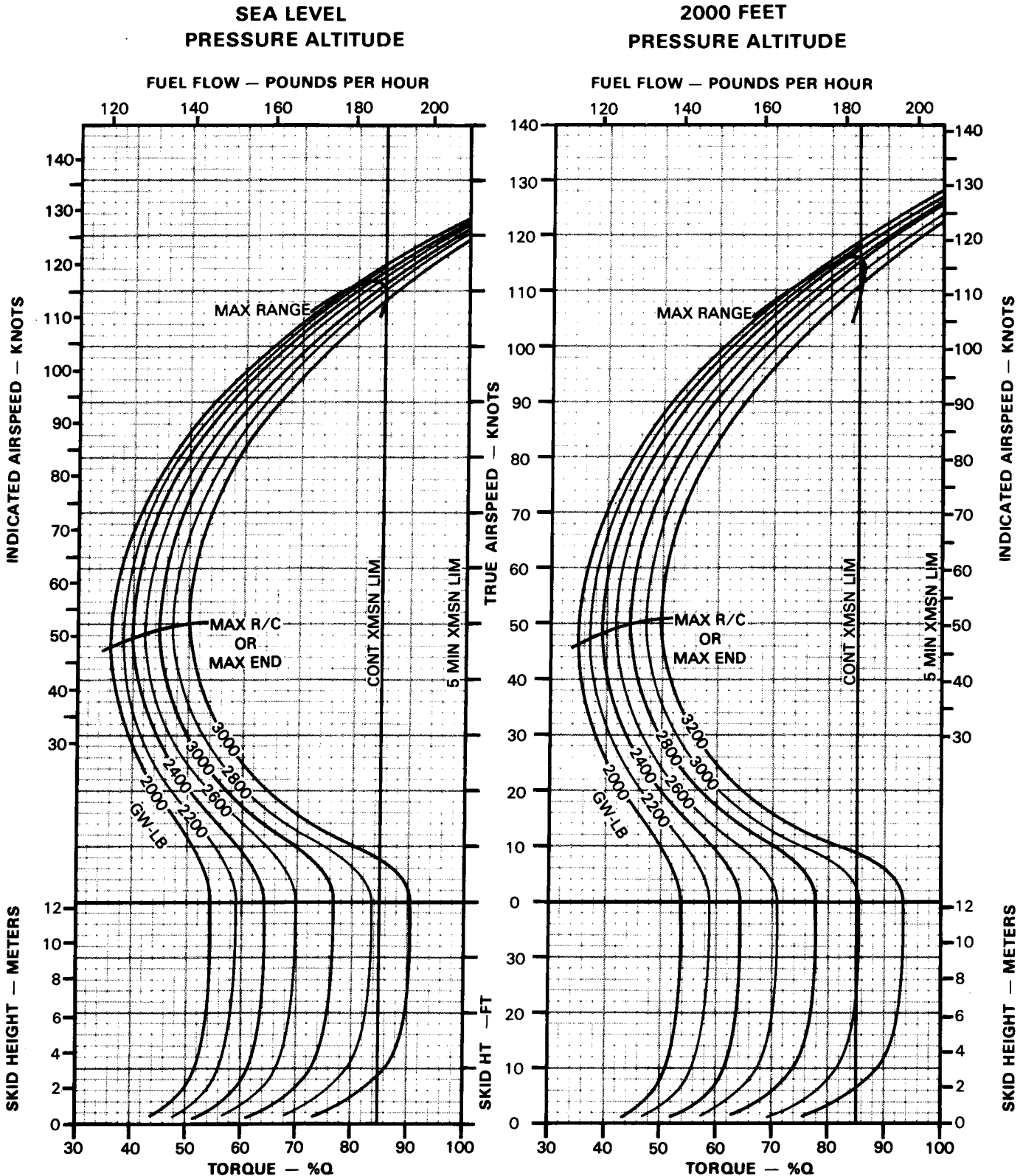



THIS IS AN UNCONTROLLED DOCUMENT. THE DATA IS PRESENTED FOR GENERAL INFORMATION ONLY. SOME INFORMATION HAS BEEN SUPERCEDED SINCE ORIGINAL PUBLICATION. PLEASE REFER TO THE CURRENT PRODUCT SPECIFICATION BOOKLET FOR UP-TO-DATE STANDARD EQUIPMENT LIST & KIT WEIGHTS, PERFORMANCE, AND DIRECT OPERATING COST.

BELL 206B JETRANGER III

CRUISE

PRESSURE ALTITUDE — 4000 TO 6000 FEET

CLEAN CONFIGURATION 100% RPM JP-4 FUEL

OAT BETWEEN -20°C AND -5°C

4000 FEET
PRESSURE ALTITUDE

6000 FEET
PRESSURE ALTITUDE

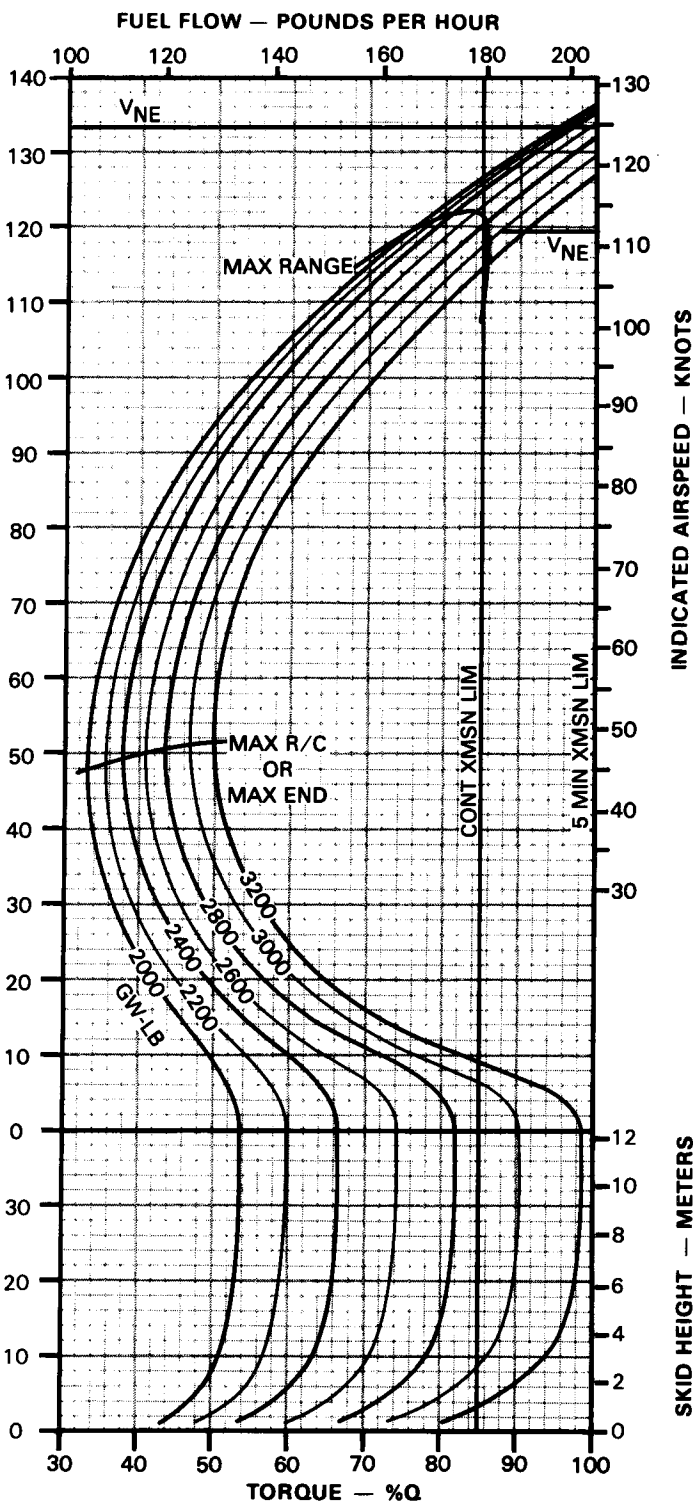
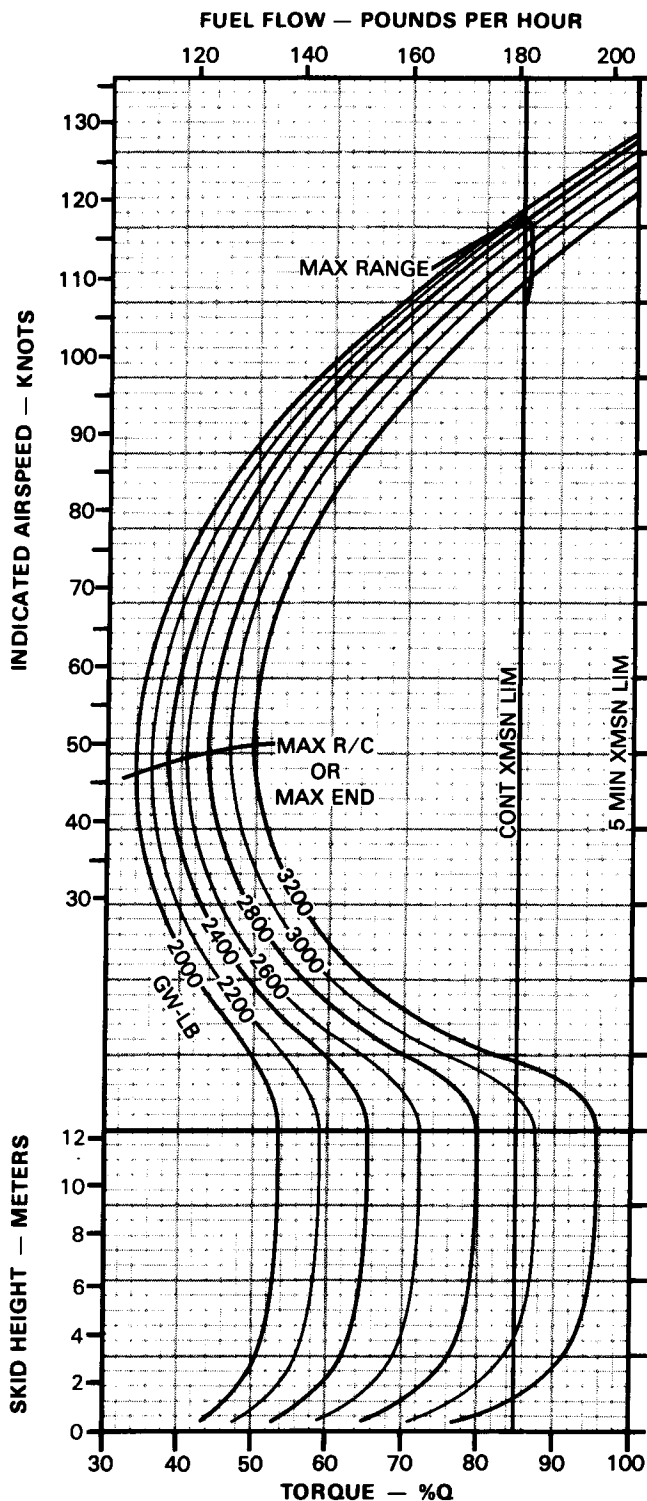



THIS IS AN UNCONTROLLED DOCUMENT. THE DATA IS PRESENTED FOR GENERAL INFORMATION ONLY. SOME INFORMATION HAS BEEN SUPERCEDED SINCE ORIGINAL PUBLICATION. PLEASE REFER TO THE CURRENT PRODUCT SPECIFICATION BOOKLET FOR UP-TO-DATE STANDARD EQUIPMENT LIST & KIT WEIGHTS, PERFORMANCE, AND DIRECT OPERATING COST.

BELL 206B JETRANGER III

CRUISE

PRESSURE ALTITUDE — 8000 TO 10000 FEET

CLEAN CONFIGURATION 100% RPM JP-4 FUEL

OAT BETWEEN -20°C AND -5°C

8000 FEET
PRESSURE ALTITUDE

10000 FEET
PRESSURE ALTITUDE

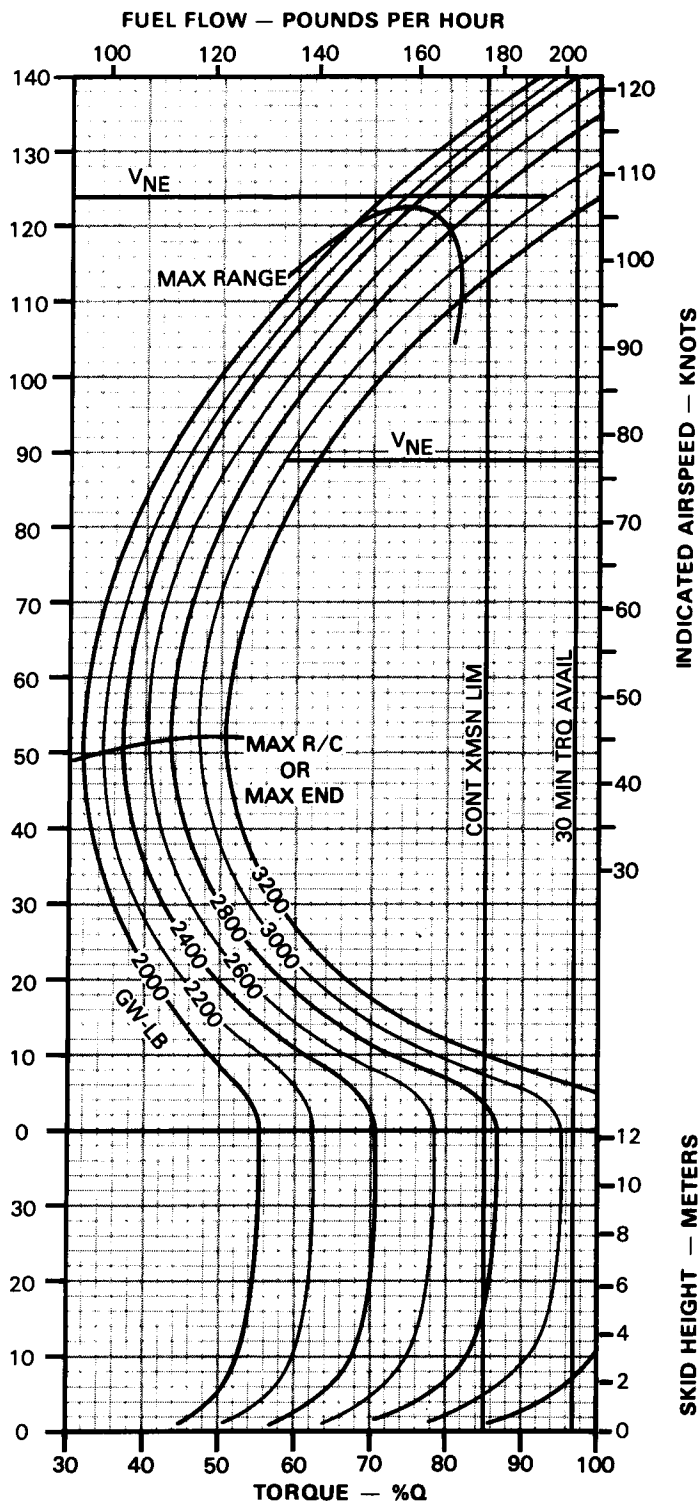
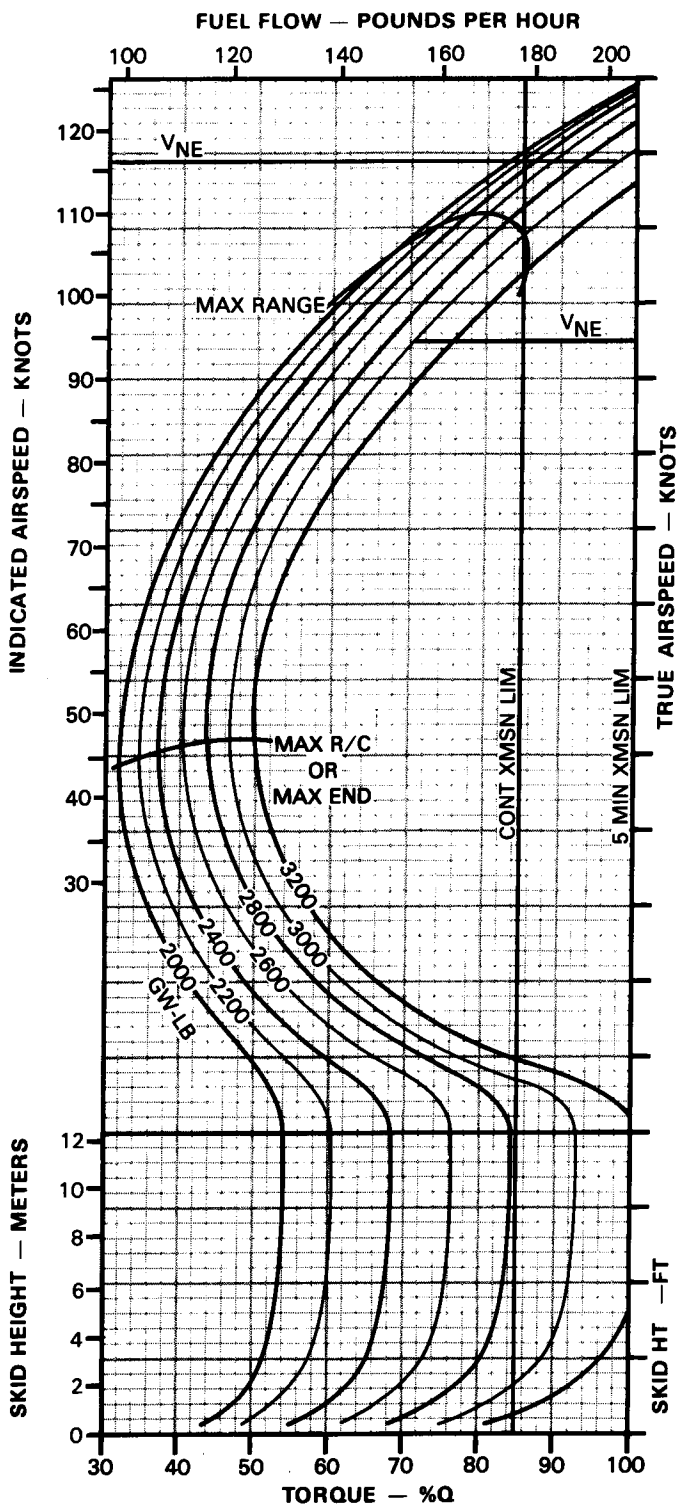

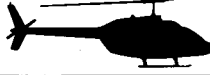

THIS IS AN UNCONTROLLED DOCUMENT. THE DATA IS PRESENTED FOR GENERAL INFORMATION ONLY. SOME INFORMATION HAS BEEN SUPERCEDED SINCE ORIGINAL PUBLICATION. PLEASE REFER TO THE CURRENT PRODUCT SPECIFICATION BOOKLET FOR UP-TO-DATE STANDARD EQUIPMENT LIST & KIT WEIGHTS, PERFORMANCE, AND DIRECT OPERATING COST.

BELL 206B JETRANGER III

CRUISE

PRESSURE ALTITUDE — 12000 TO 14000 FEET
CLEAN CONFIGURATION 100% RPM JP-4 FUEL

OAT BETWEEN -20°C AND -5°C

**12000 FEET
PRESSURE ALTITUDE**

**14000 FEET
PRESSURE ALTITUDE**

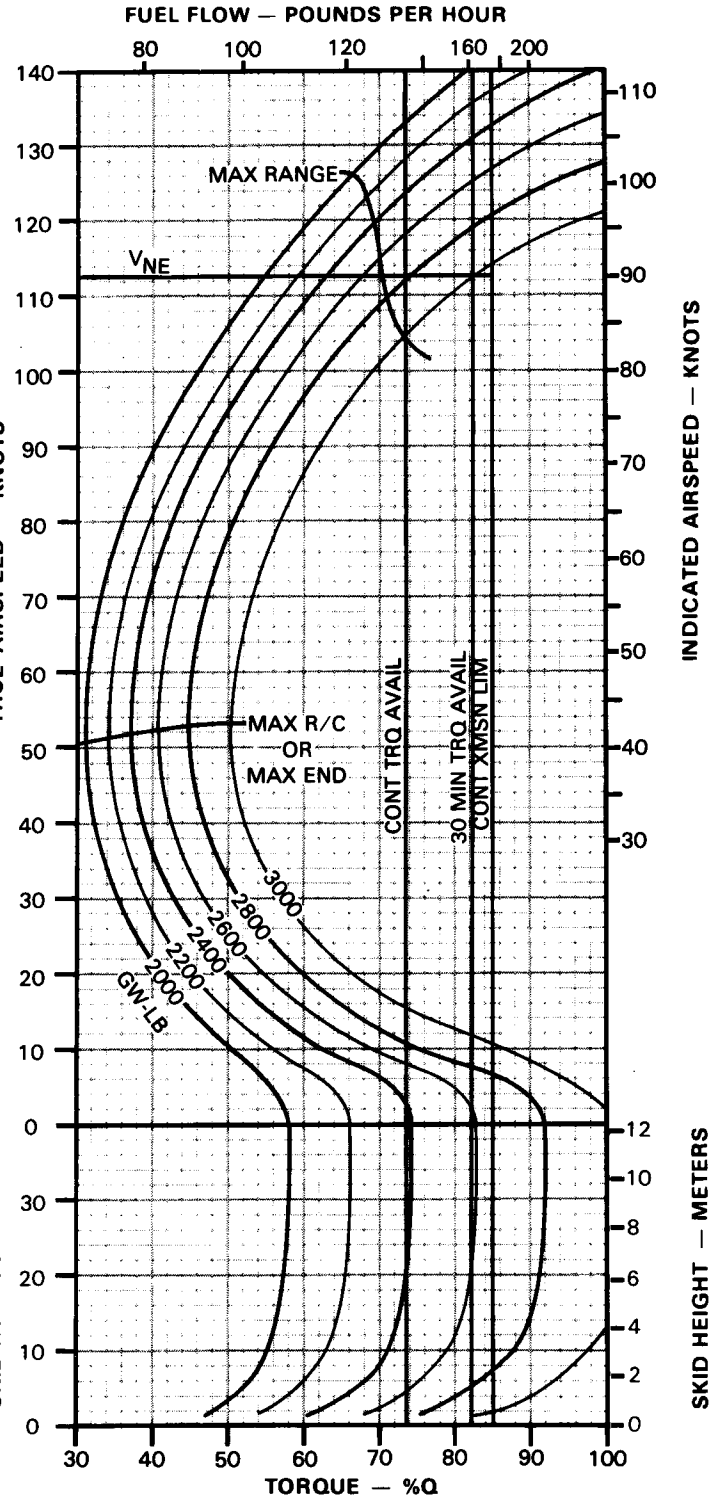
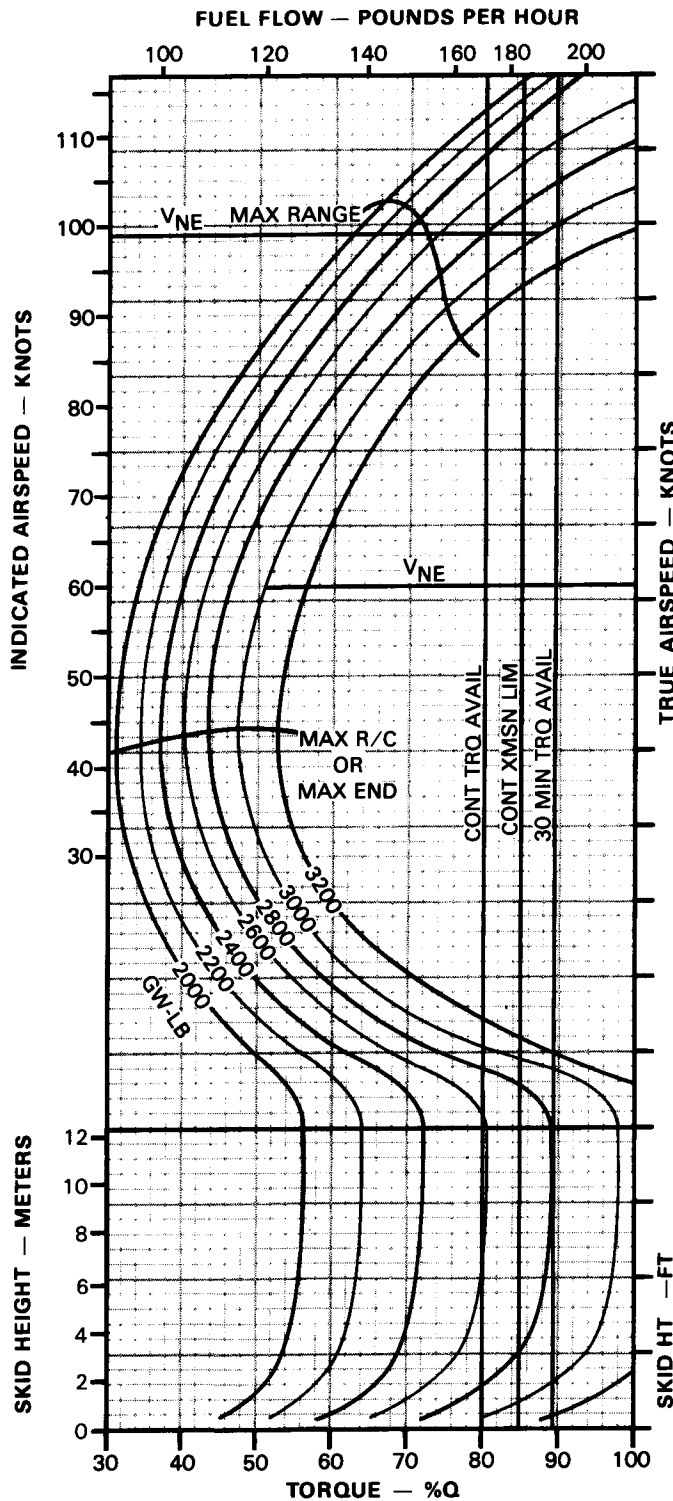



THIS IS AN UNCONTROLLED DOCUMENT. THE DATA IS PRESENTED FOR GENERAL INFORMATION ONLY. SOME INFORMATION HAS BEEN SUPERCEDED SINCE ORIGINAL PUBLICATION. PLEASE REFER TO THE CURRENT PRODUCT SPECIFICATION BOOKLET FOR UP-TO-DATE STANDARD EQUIPMENT LIST & KIT WEIGHTS, PERFORMANCE, AND DIRECT OPERATING COST.

BELL 206B JETRANGER III

CRUISE PRESSURE ALTITUDE — SEA LEVEL TO 2000 FEET CLEAN CONFIGURATION 100% RPM JP-4 FUEL

OAT BETWEEN -5°C AND +15°C

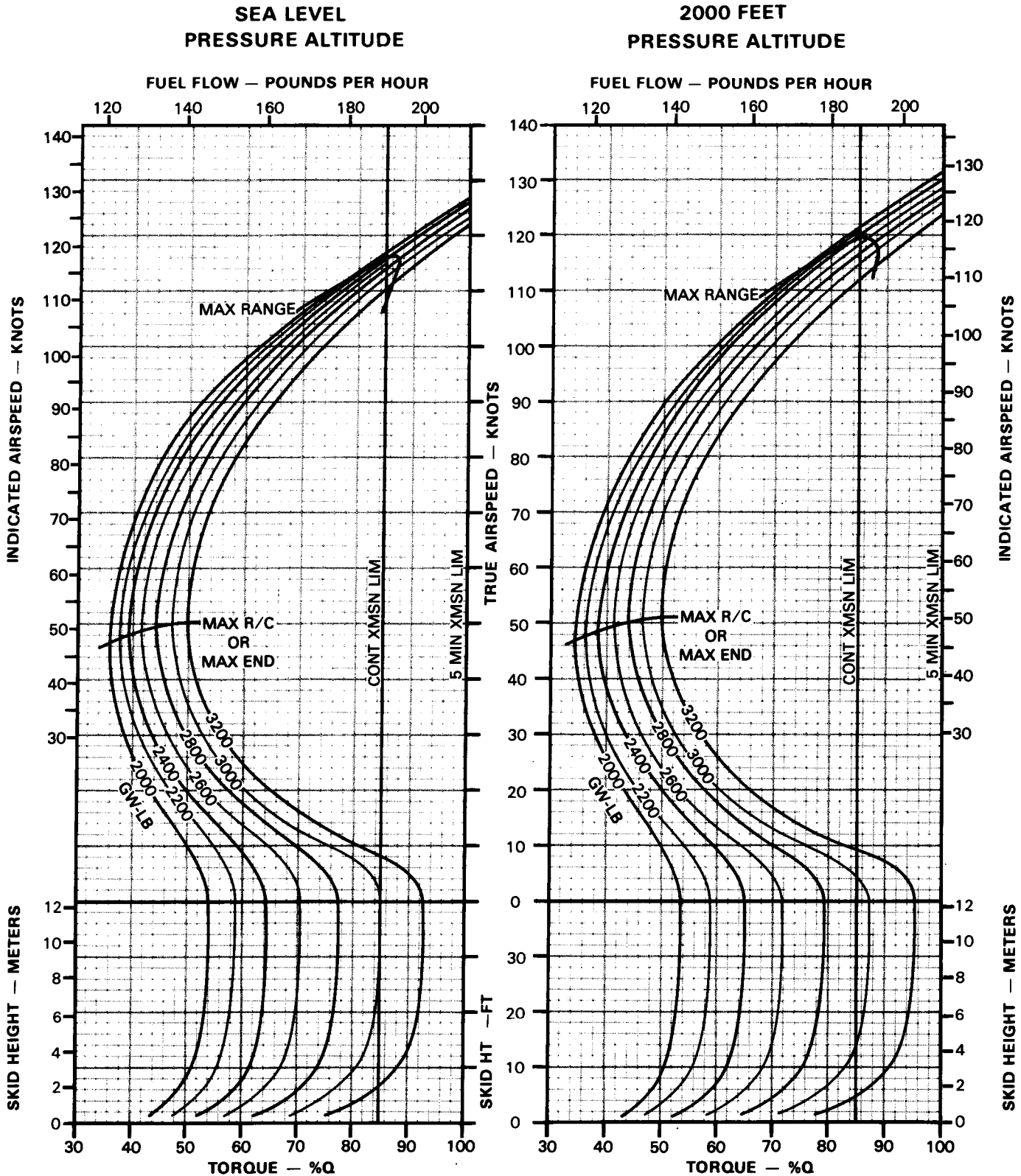



THIS IS AN UNCONTROLLED DOCUMENT. THE DATA IS PRESENTED FOR GENERAL INFORMATION ONLY. SOME INFORMATION HAS BEEN SUPERCEDED SINCE ORIGINAL PUBLICATION. PLEASE REFER TO THE CURRENT PRODUCT SPECIFICATION BOOKLET FOR UP-TO-DATE STANDARD EQUIPMENT LIST & KIT WEIGHTS, PERFORMANCE, AND DIRECT OPERATING COST.

BELL 206B JETRANGER III

CRUISE

PRESSURE ALTITUDE — 4000 TO 6000 FEET

CLEAN CONFIGURATION 100% RPM JP-4 FUEL

OAT BETWEEN -5°C AND +15°C

4000 FEET
PRESSURE ALTITUDE

6000 FEET
PRESSURE ALTITUDE

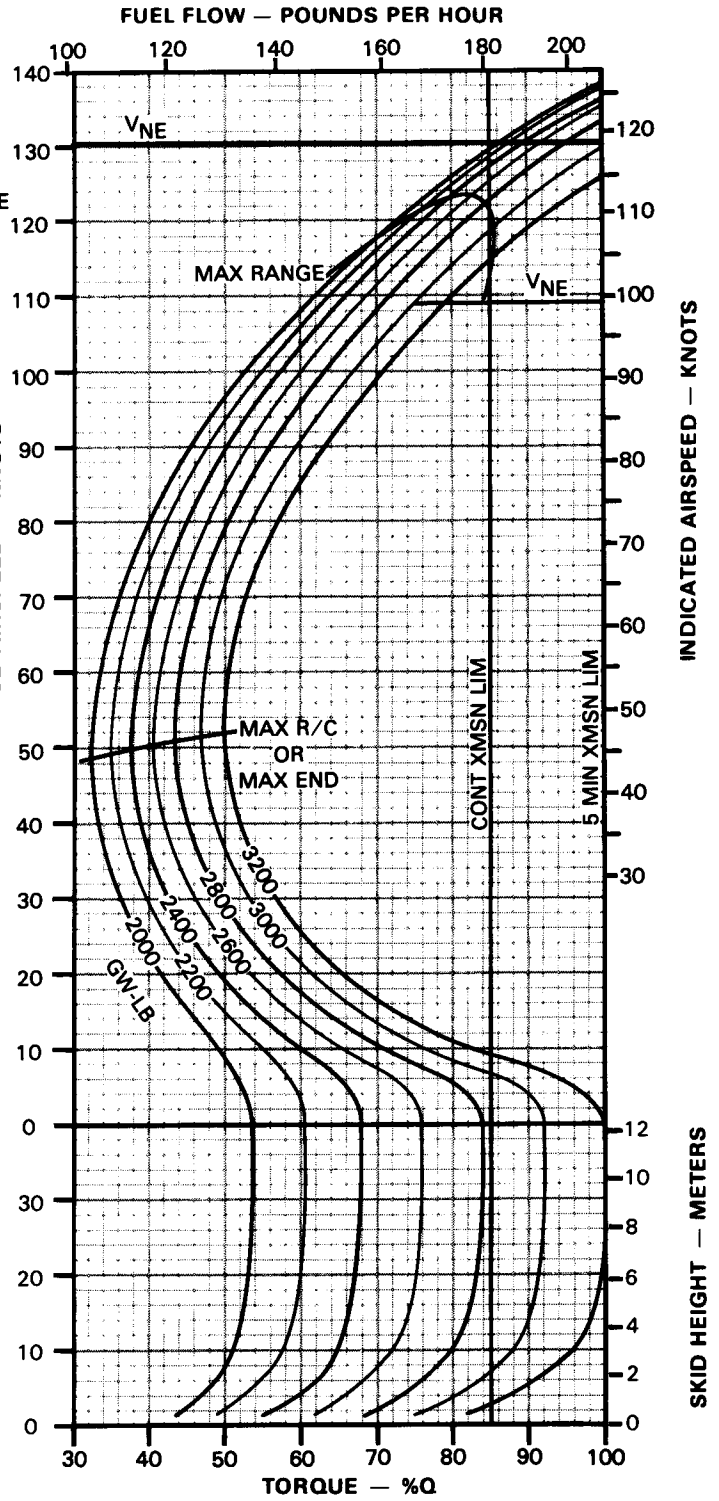
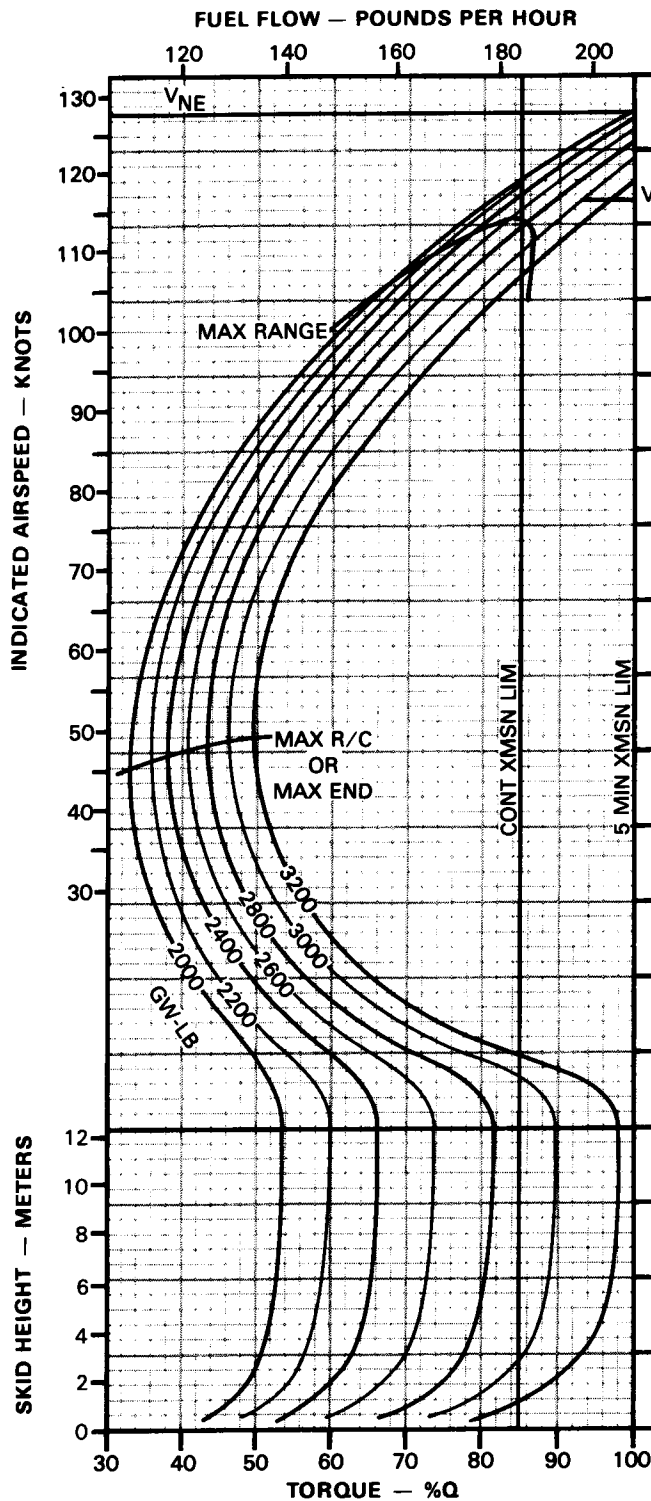



THIS IS AN UNCONTROLLED DOCUMENT. THE DATA IS PRESENTED FOR GENERAL INFORMATION ONLY. SOME INFORMATION HAS BEEN SUPERCEDED SINCE ORIGINAL PUBLICATION. PLEASE REFER TO THE CURRENT PRODUCT SPECIFICATION BOOKLET FOR UP-TO-DATE STANDARD EQUIPMENT LIST & KIT WEIGHTS, PERFORMANCE, AND DIRECT OPERATING COST.

BELL 206B JETRANGER III

CRUISE PRESSURE ALTITUDE — 8000 TO 10000 FEET CLEAN CONFIGURATION 100% RPM JP-4 FUEL

OAT BETWEEN -5°C AND +15°C

8000 FEET PRESSURE ALTITUDE

10000 FEET PRESSURE ALTITUDE

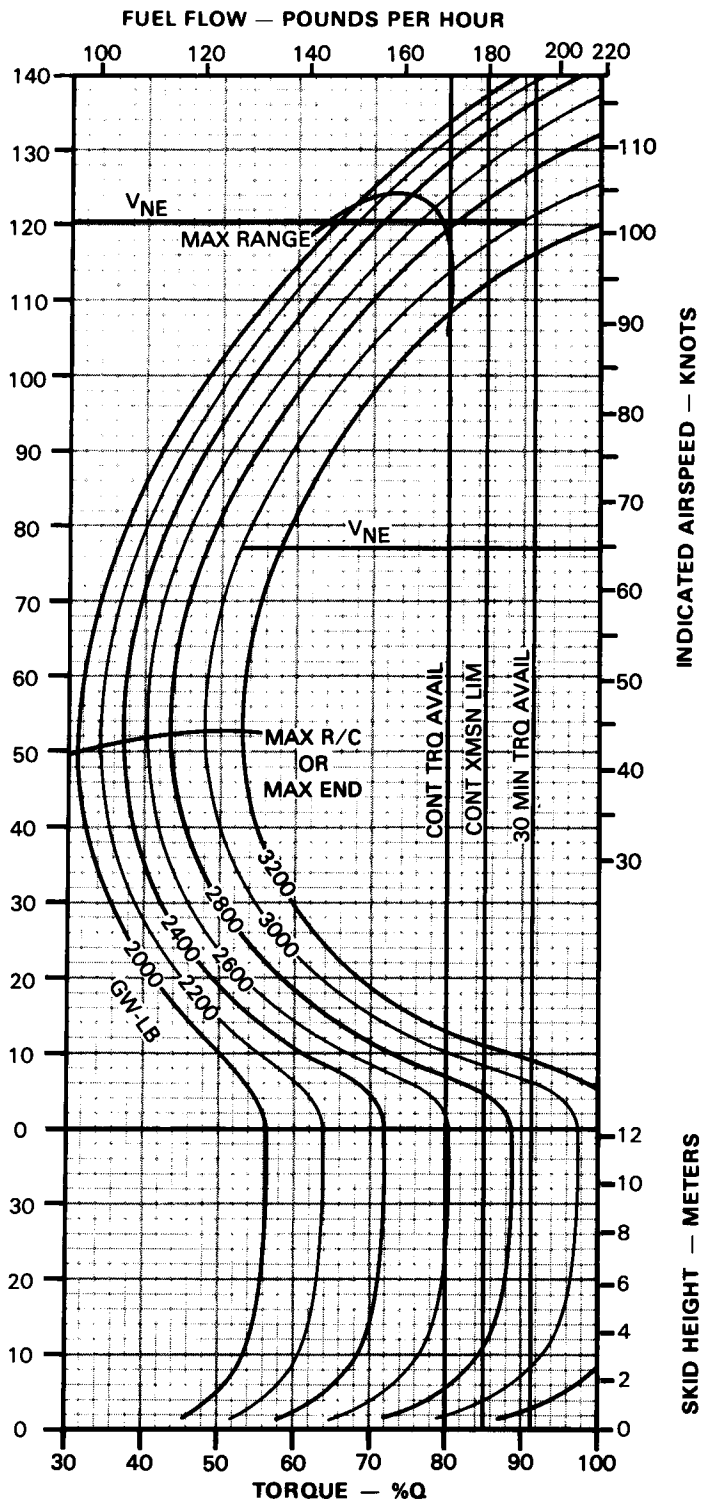
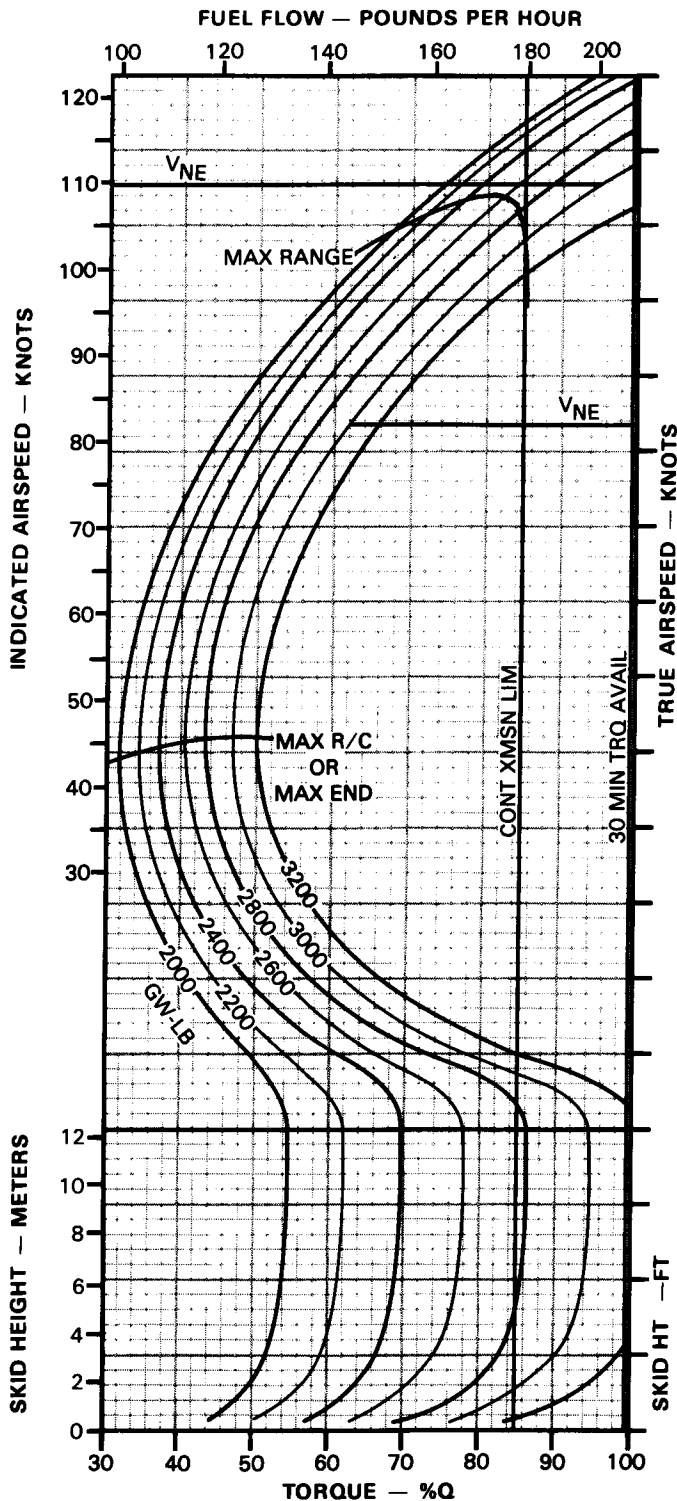

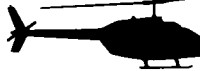

THIS IS AN UNCONTROLLED DOCUMENT. THE DATA IS PRESENTED FOR GENERAL INFORMATION ONLY. SOME INFORMATION HAS BEEN SUPERCEDED SINCE ORIGINAL PUBLICATION. PLEASE REFER TO THE CURRENT PRODUCT SPECIFICATION BOOKLET FOR UP-TO-DATE STANDARD EQUIPMENT LIST & KIT WEIGHTS, PERFORMANCE, AND DIRECT OPERATING COST.

BELL 206B JETRANGER III

CRUISE

PRESSURE ALTITUDE — 12000 TO 14000 FEET

CLEAN CONFIGURATION 100% RPM JP-4 FUEL

OAT BETWEEN -5°C AND +15°C

12000 FEET
PRESSURE ALTITUDE

14000 FEET
PRESSURE ALTITUDE

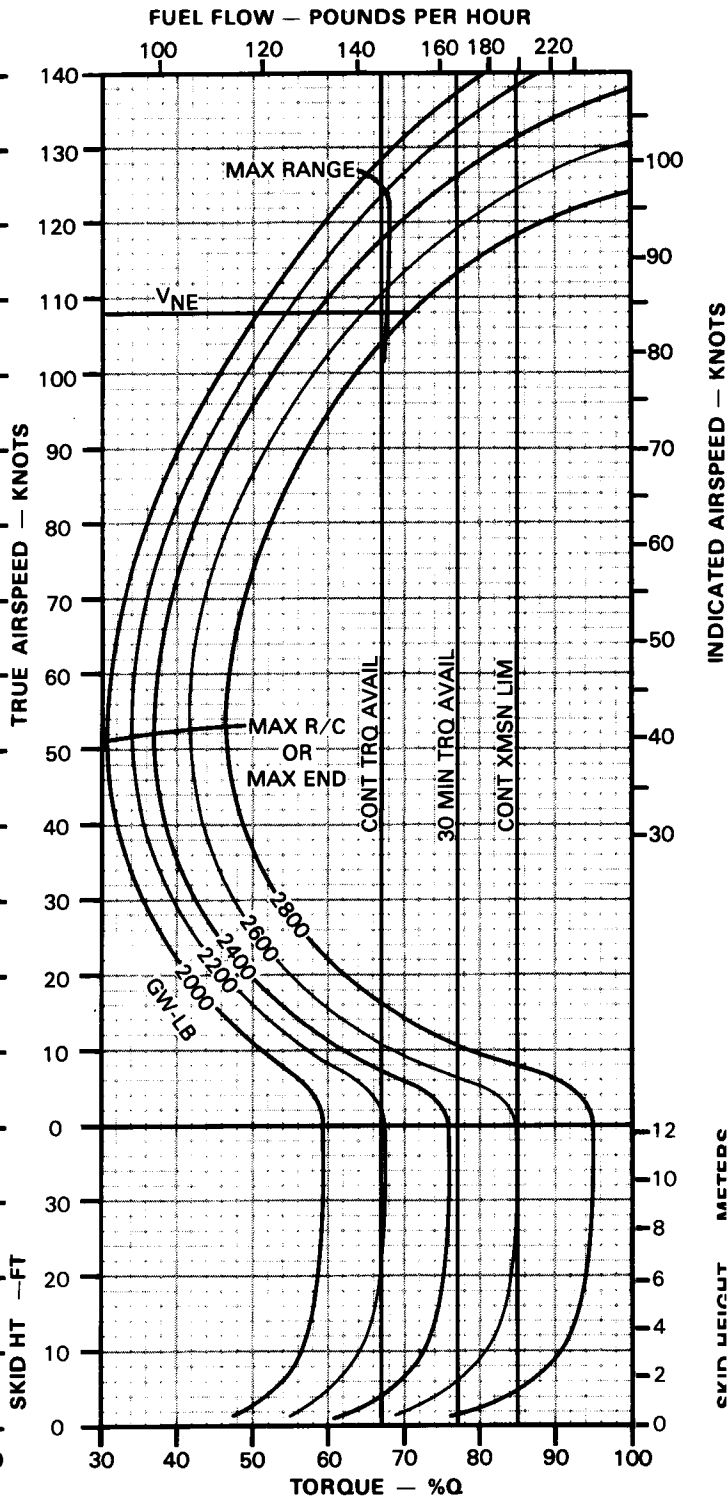
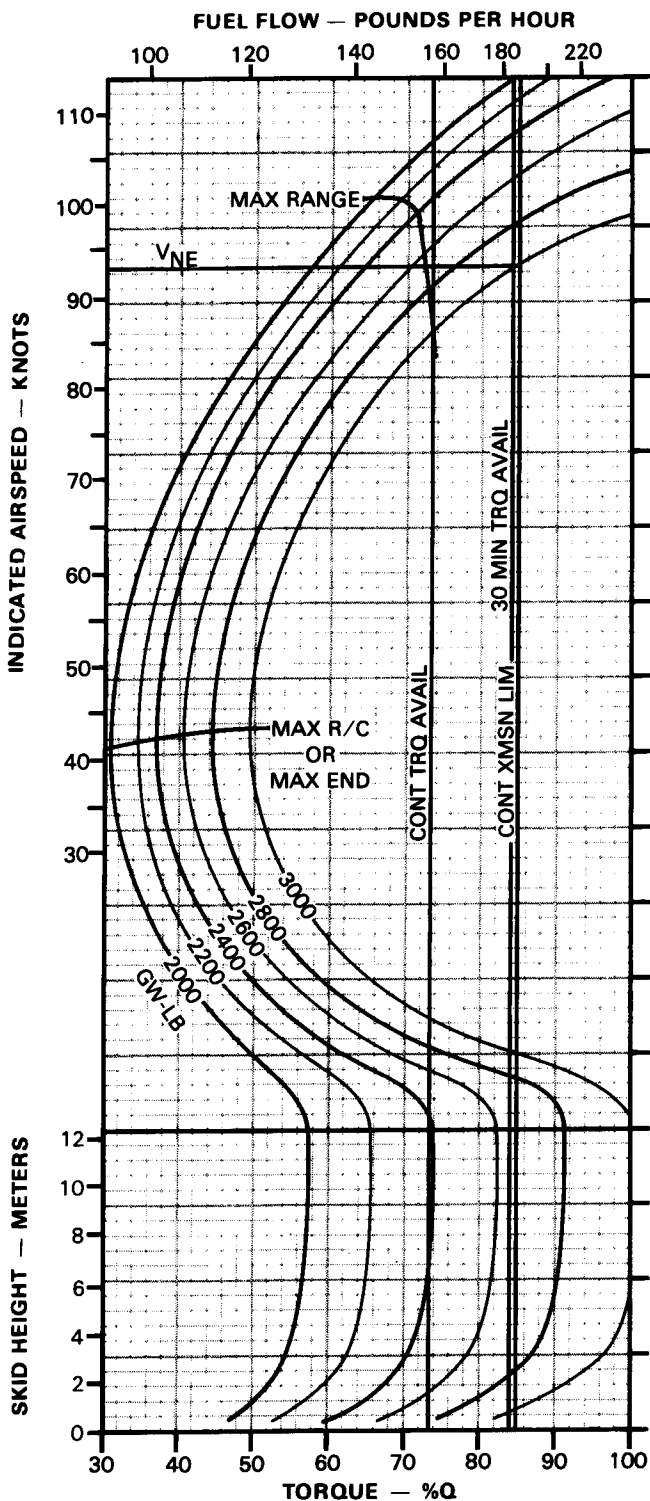



THIS IS AN UNCONTROLLED DOCUMENT. THE DATA IS PRESENTED FOR GENERAL INFORMATION ONLY. SOME INFORMATION HAS BEEN SUPERCEDED SINCE ORIGINAL PUBLICATION. PLEASE REFER TO THE CURRENT PRODUCT SPECIFICATION BOOKLET FOR UP-TO-DATE STANDARD EQUIPMENT LIST & KIT WEIGHTS, PERFORMANCE, AND DIRECT OPERATING COST.

BELL 206B JETRANGER III

CRUISE

PRESSURE ALTITUDE — SEA LEVEL TO 2000 FEET
CLEAN CONFIGURATION 100% RPM JP-4 FUEL

OAT BETWEEN +15°C AND +30°C

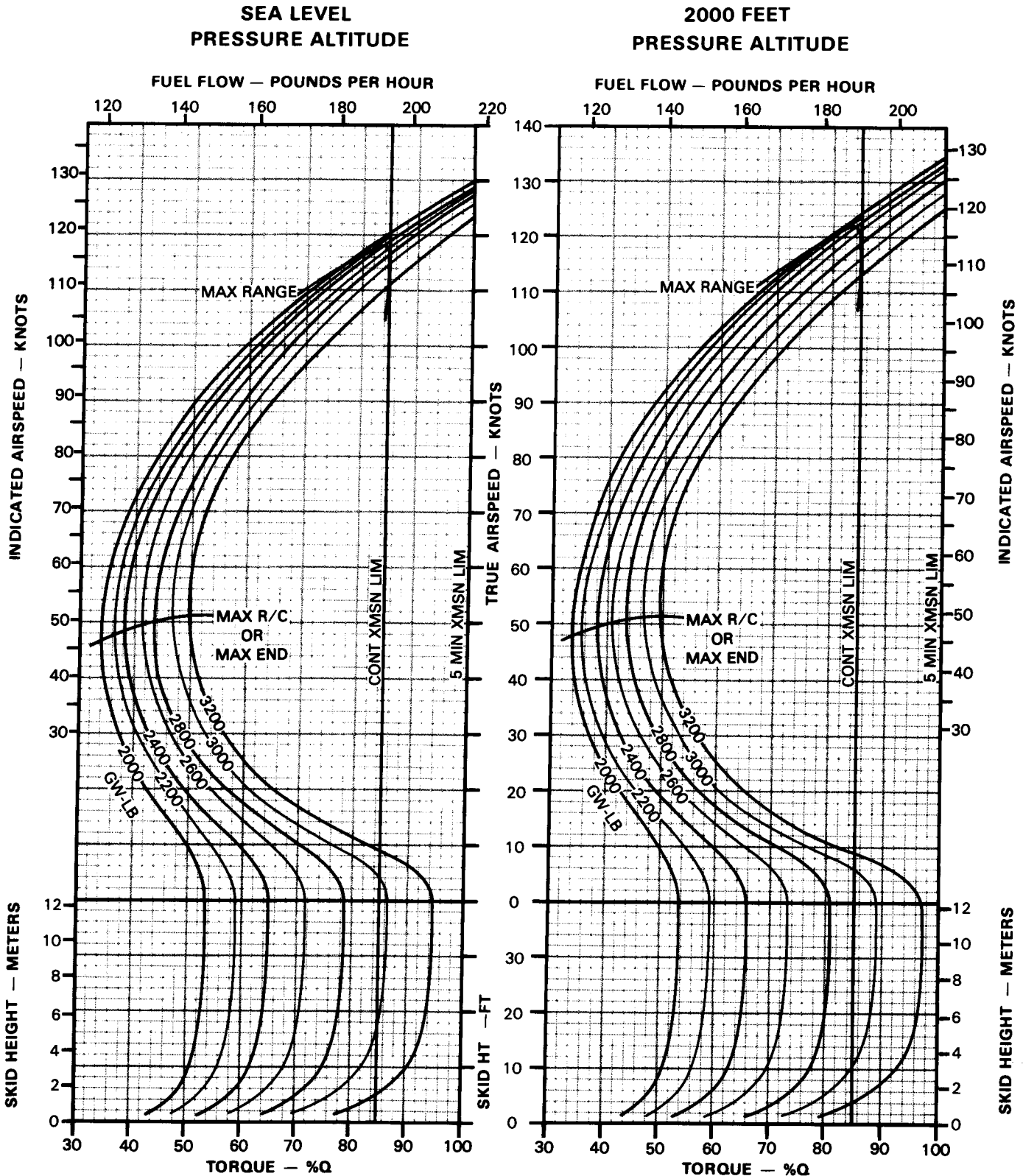



THIS IS AN UNCONTROLLED DOCUMENT. THE DATA IS PRESENTED FOR GENERAL INFORMATION ONLY. SOME INFORMATION HAS BEEN SUPERCEDED SINCE ORIGINAL PUBLICATION. PLEASE REFER TO THE CURRENT PRODUCT SPECIFICATION BOOKLET FOR UP-TO-DATE STANDARD EQUIPMENT LIST & KIT WEIGHTS, PERFORMANCE, AND DIRECT OPERATING COST.

BELL 206B JETRANGER III

CRUISE

PRESSURE ALTITUDE — 4000 TO 6000 FEET

CLEAN CONFIGURATION 100% RPM JP-4 FUEL

OAT BETWEEN +15°C AND +30°C

4000 FEET
PRESSURE ALTITUDE

6000 FEET
PRESSURE ALTITUDE

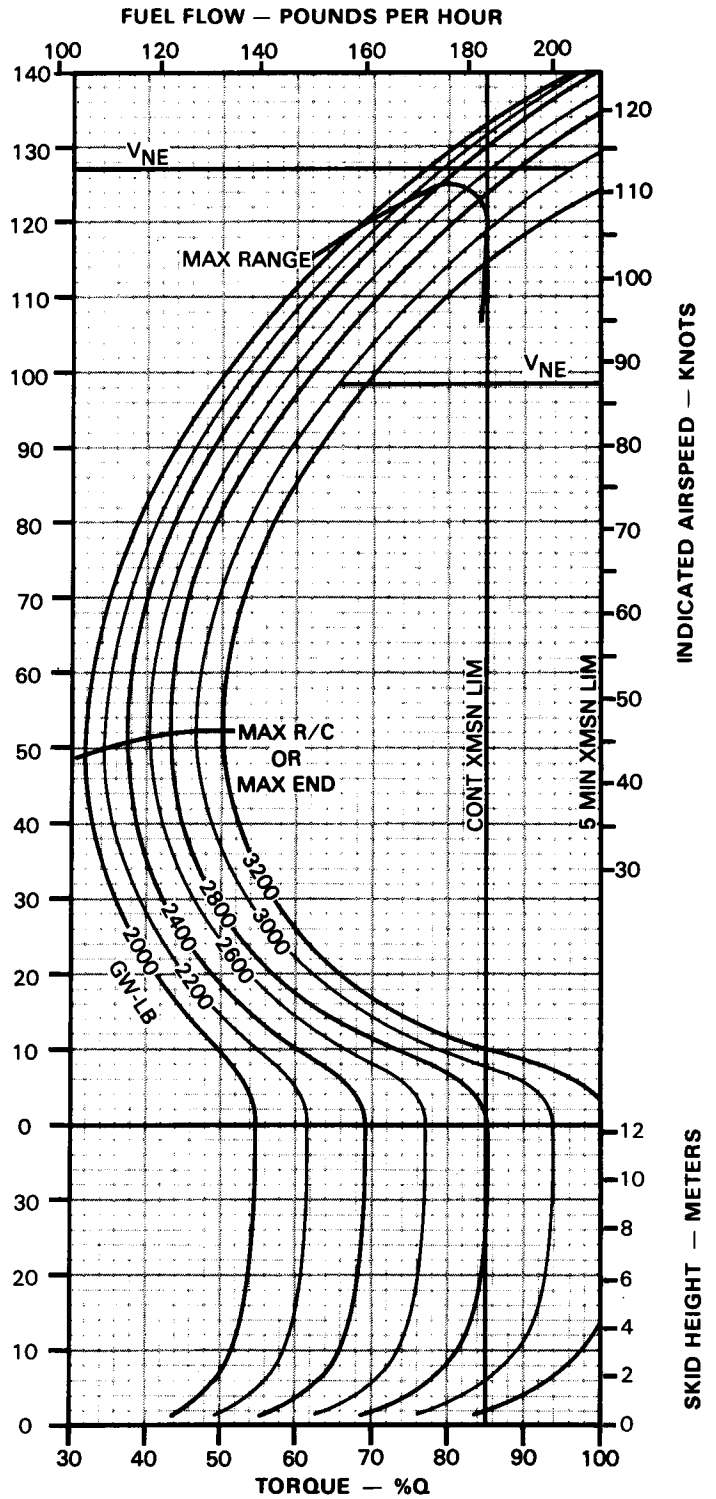
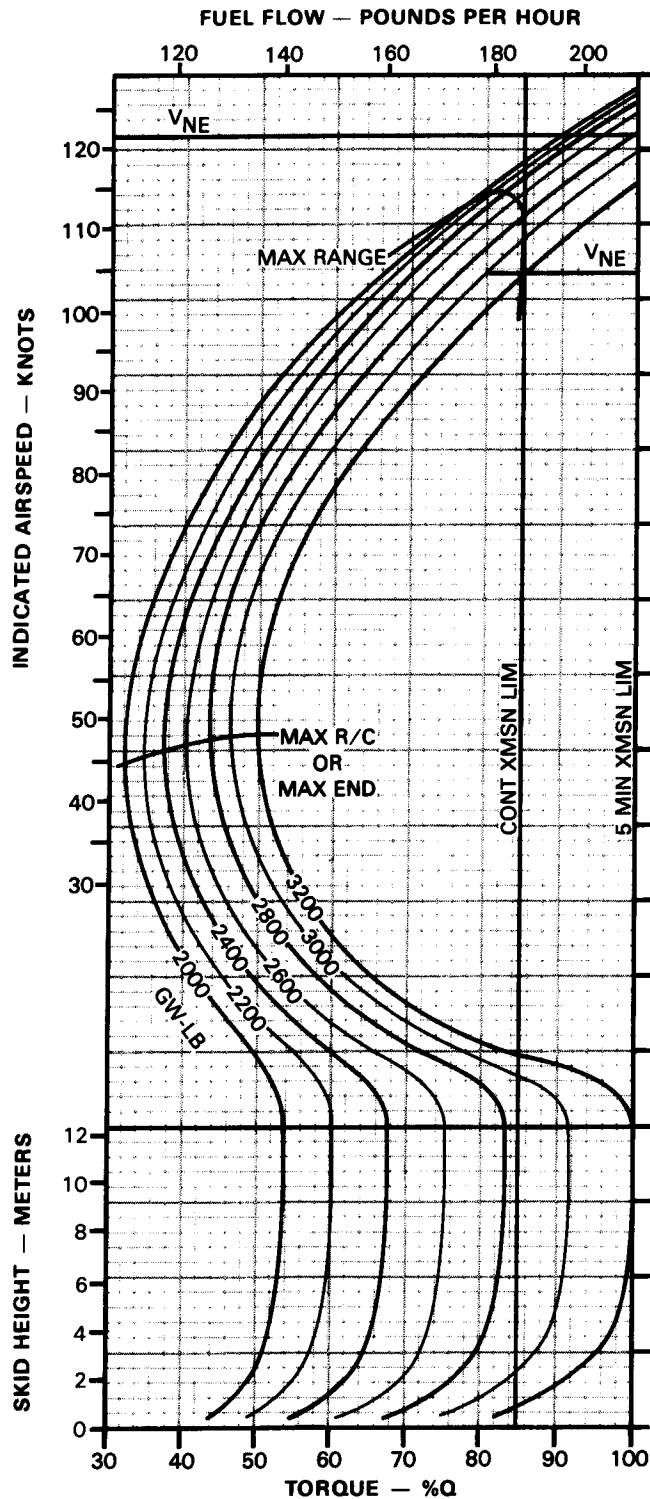



THIS IS AN UNCONTROLLED DOCUMENT. THE DATA IS PRESENTED FOR GENERAL INFORMATION ONLY. SOME INFORMATION HAS BEEN SUPERCEDED SINCE ORIGINAL PUBLICATION. PLEASE REFER TO THE CURRENT PRODUCT SPECIFICATION BOOKLET FOR UP-TO-DATE STANDARD EQUIPMENT LIST & KIT WEIGHTS, PERFORMANCE, AND DIRECT OPERATING COST.

**BELL 206B
JETRANGER III**

CRUISE

PRESSURE ALTITUDE — 8000 TO 10000 FEET

CLEAN CONFIGURATION 100% RPM JP-4 FUEL

OAT BETWEEN +15°C AND +30°C

**8000 FEET
PRESSURE ALTITUDE**

**10000 FEET
PRESSURE ALTITUDE**

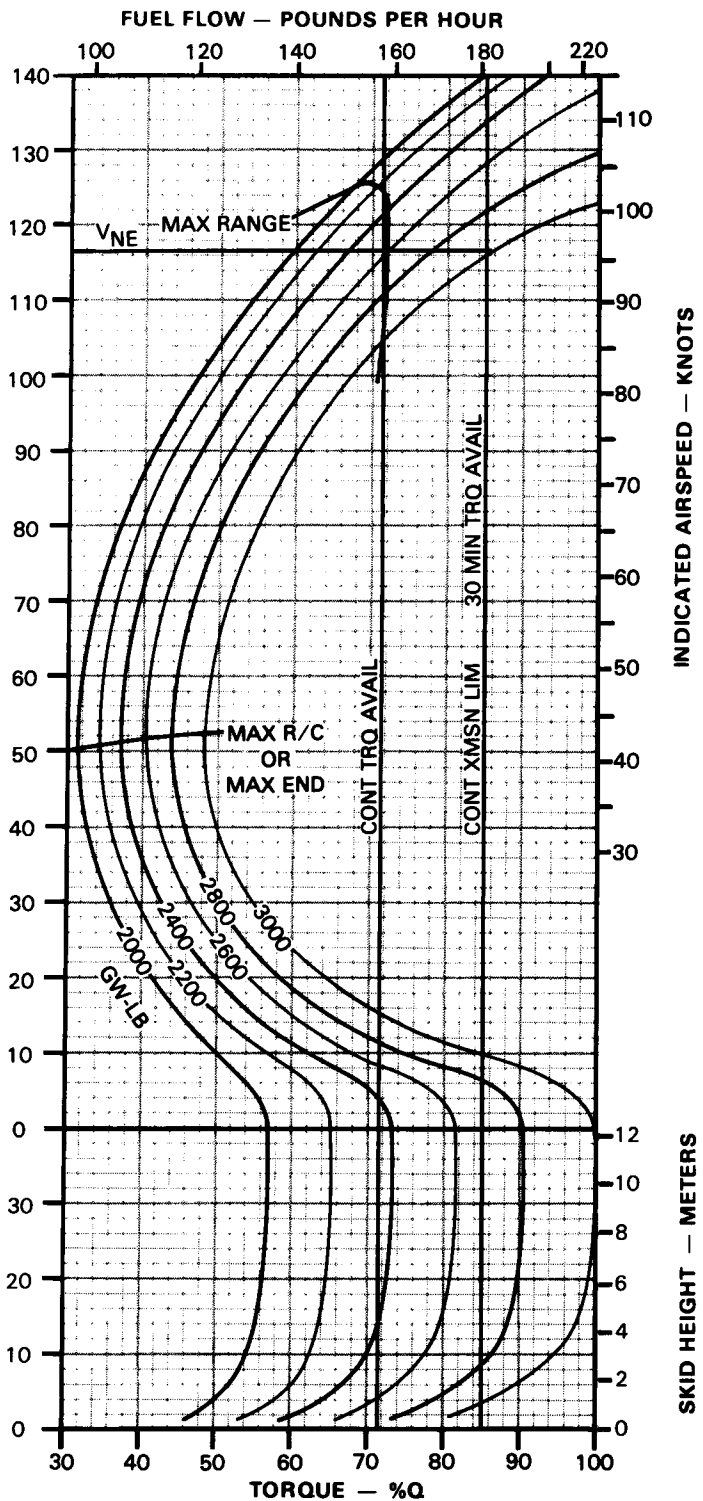
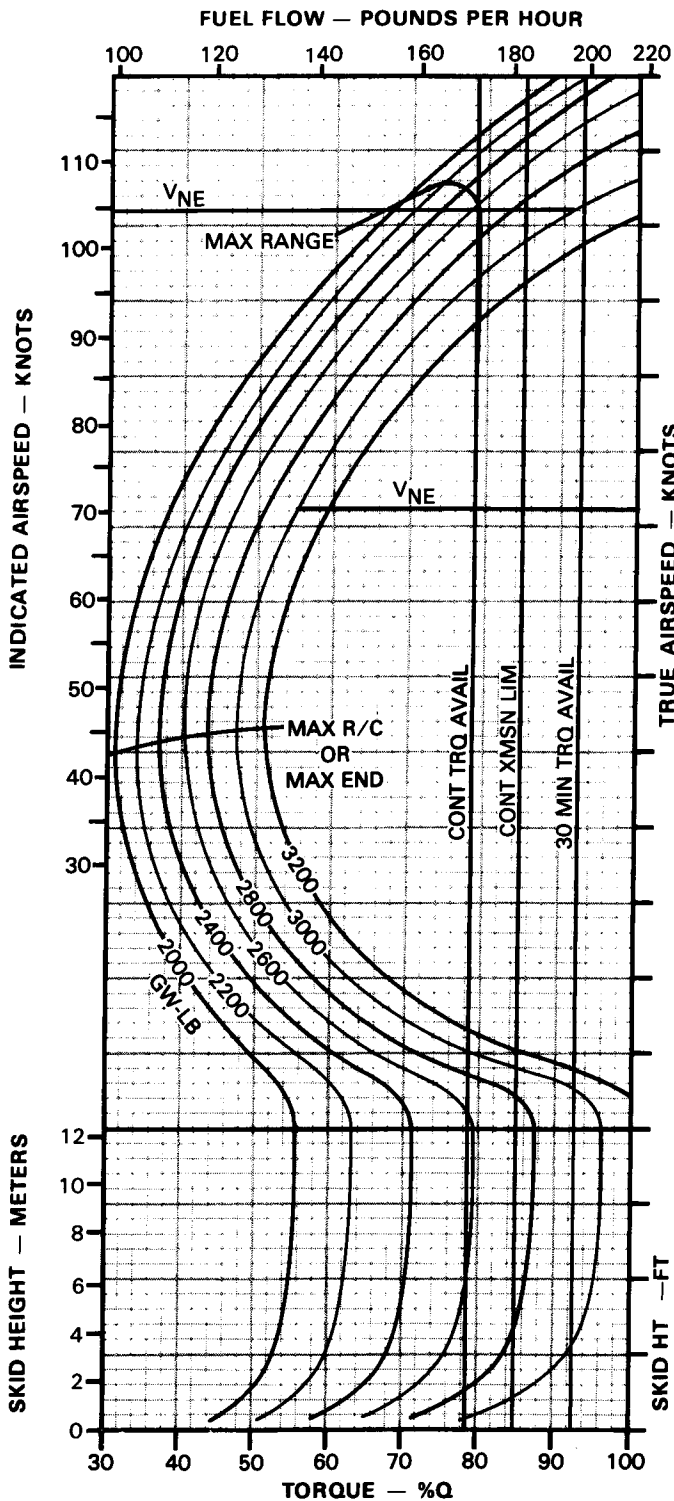



THIS IS AN UNCONTROLLED DOCUMENT. THE DATA IS PRESENTED FOR GENERAL INFORMATION ONLY. SOME INFORMATION HAS BEEN SUPERCEDED SINCE ORIGINAL PUBLICATION. PLEASE REFER TO THE CURRENT PRODUCT SPECIFICATION BOOKLET FOR UP-TO-DATE STANDARD EQUIPMENT LIST & KIT WEIGHTS, PERFORMANCE, AND DIRECT OPERATING COST.

BELL 206B JETRANGER III

CRUISE

PRESSURE ALTITUDE — 12000 TO 14000 FEET

CLEAN CONFIGURATION 100% RPM JP-4 FUEL

OAT BETWEEN +15°C AND +30°C

12000 FEET
PRESSURE ALTITUDE

14000 FEET
PRESSURE ALTITUDE

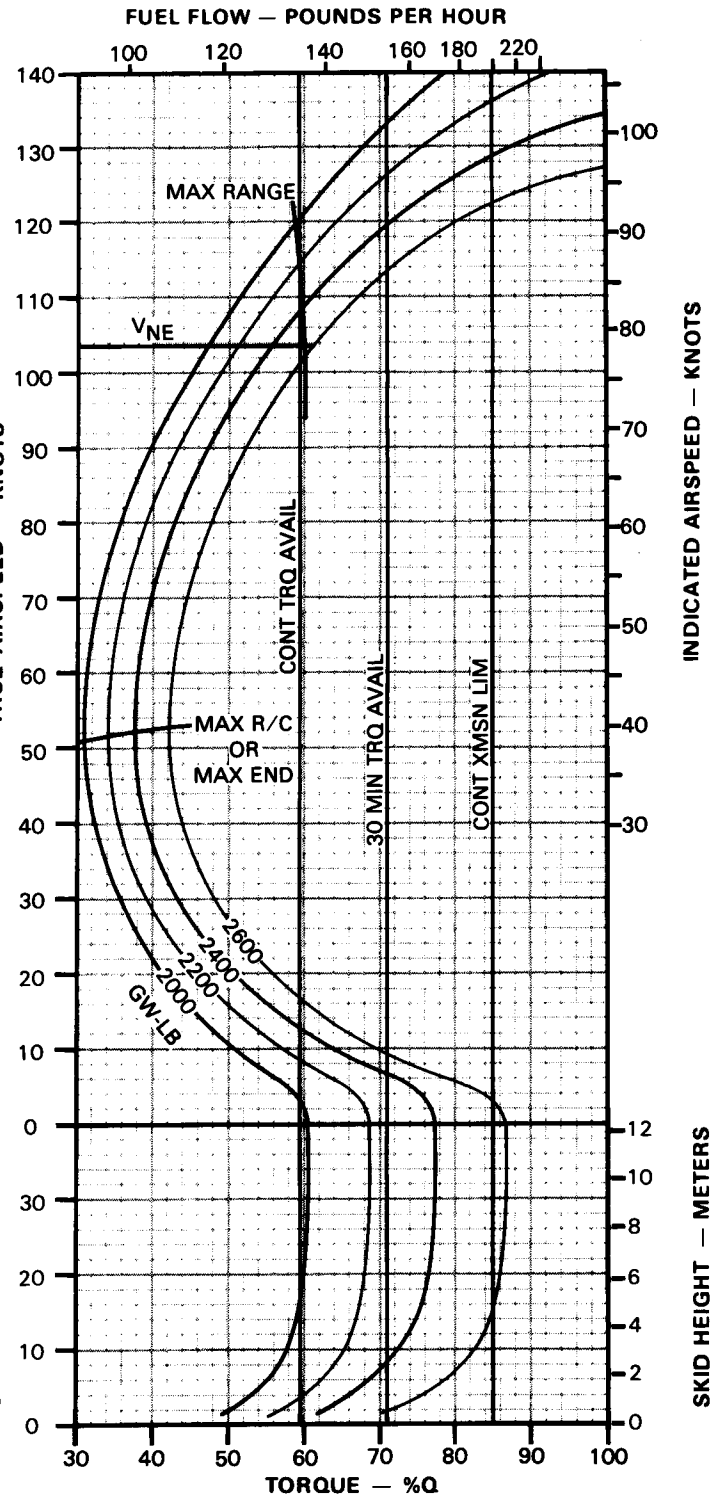
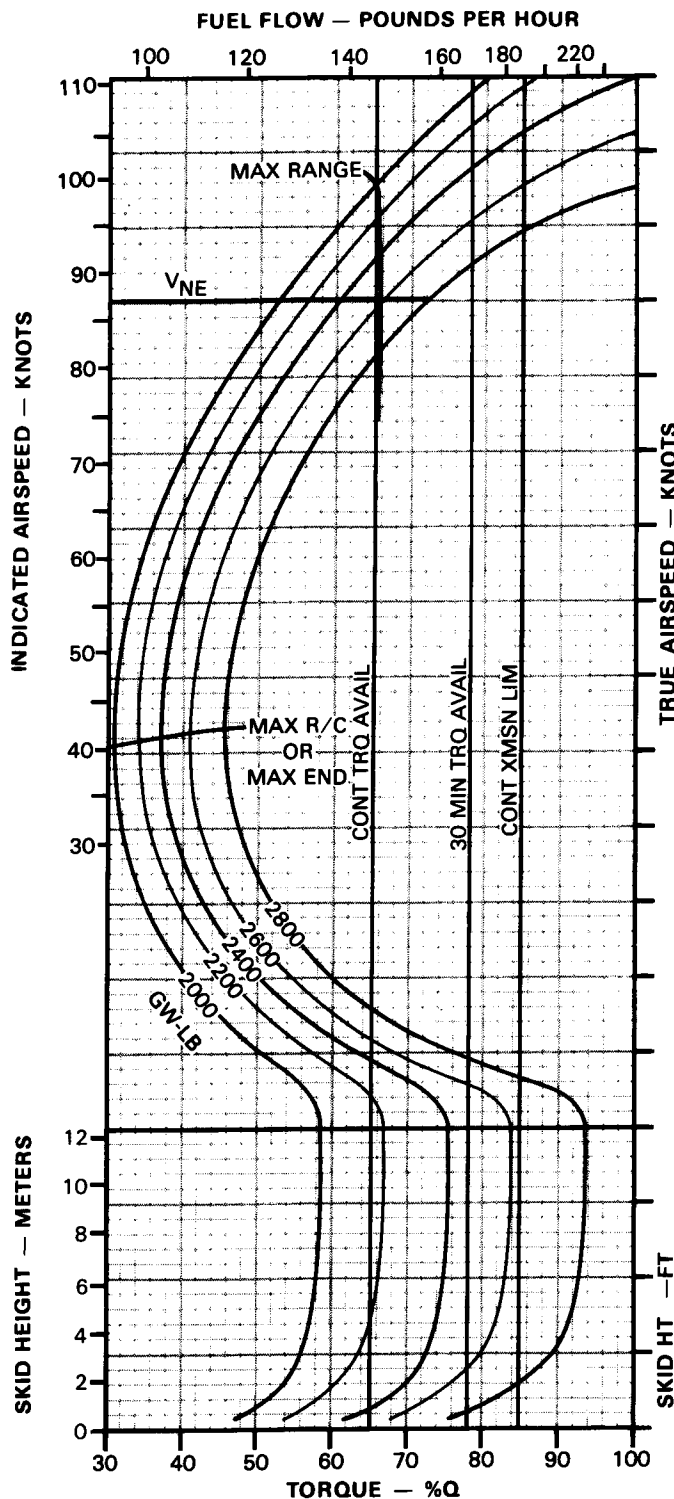



THIS IS AN UNCONTROLLED DOCUMENT. THE DATA IS PRESENTED FOR GENERAL INFORMATION ONLY. SOME INFORMATION HAS BEEN SUPERCEDED SINCE ORIGINAL PUBLICATION. PLEASE REFER TO THE CURRENT PRODUCT SPECIFICATION BOOKLET FOR UP-TO-DATE STANDARD EQUIPMENT LIST & KIT WEIGHTS, PERFORMANCE, AND DIRECT OPERATING COST.

BELL 206B JETRANGER III

CRUISE

PRESSURE ALTITUDE — SEA LEVEL TO 2000 FEET
CLEAN CONFIGURATION 100% RPM JP-4 FUEL

OAT WARMER THAN +30°C

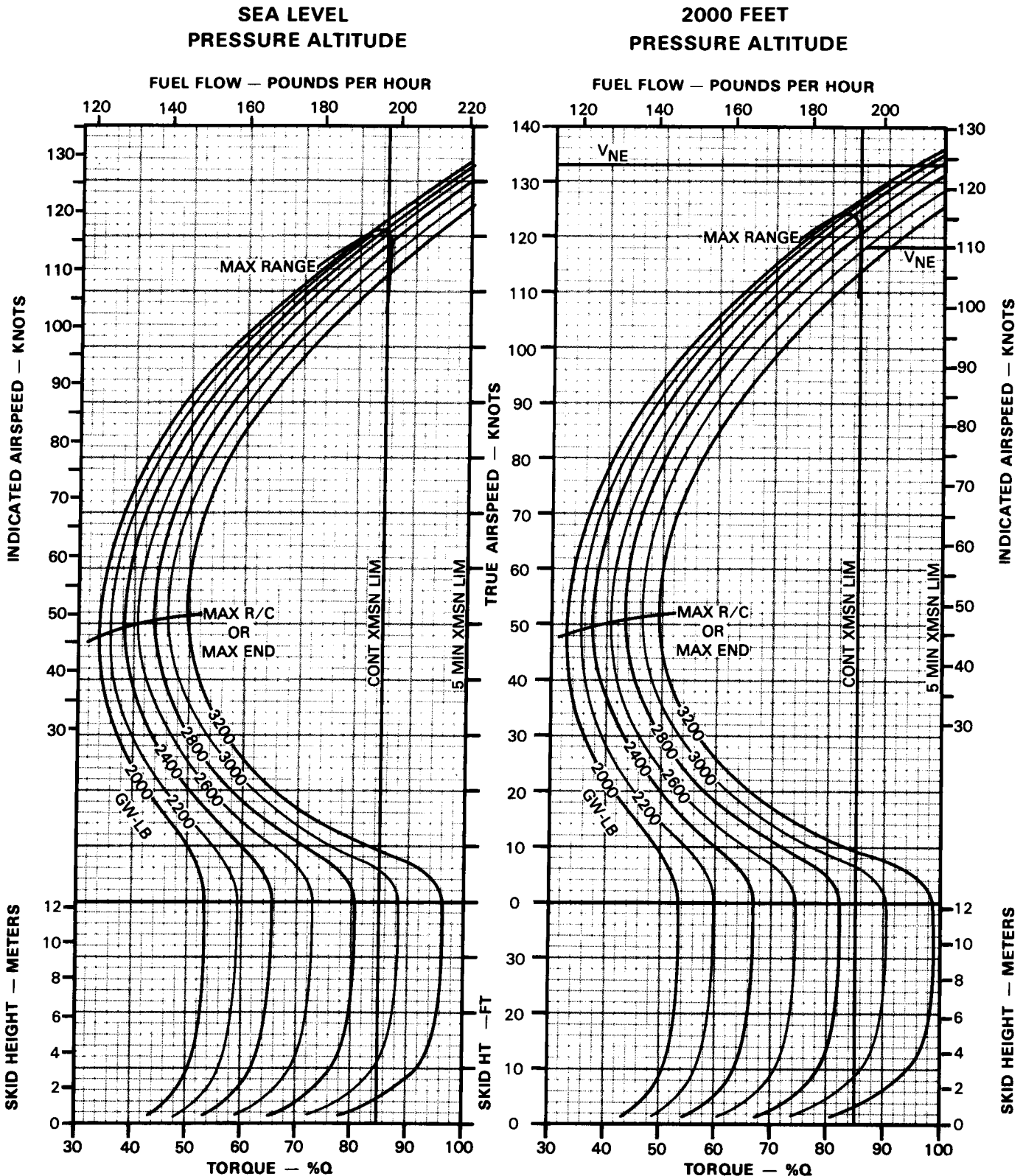



THIS IS AN UNCONTROLLED DOCUMENT. THE DATA IS PRESENTED FOR GENERAL INFORMATION ONLY. SOME INFORMATION HAS BEEN SUPERCEDED SINCE ORIGINAL PUBLICATION. PLEASE REFER TO THE CURRENT PRODUCT SPECIFICATION BOOKLET FOR UP-TO-DATE STANDARD EQUIPMENT LIST & KIT WEIGHTS, PERFORMANCE, AND DIRECT OPERATING COST.

BELL 206B JETRANGER III

CRUISE

PRESSURE ALTITUDE — 4000 TO 6000 FEET

CLEAN CONFIGURATION 100% RPM JP-4 FUEL

OAT WARMER THAN +30°C

4000 FEET
PRESSURE ALTITUDE

6000 FEET
PRESSURE ALTITUDE

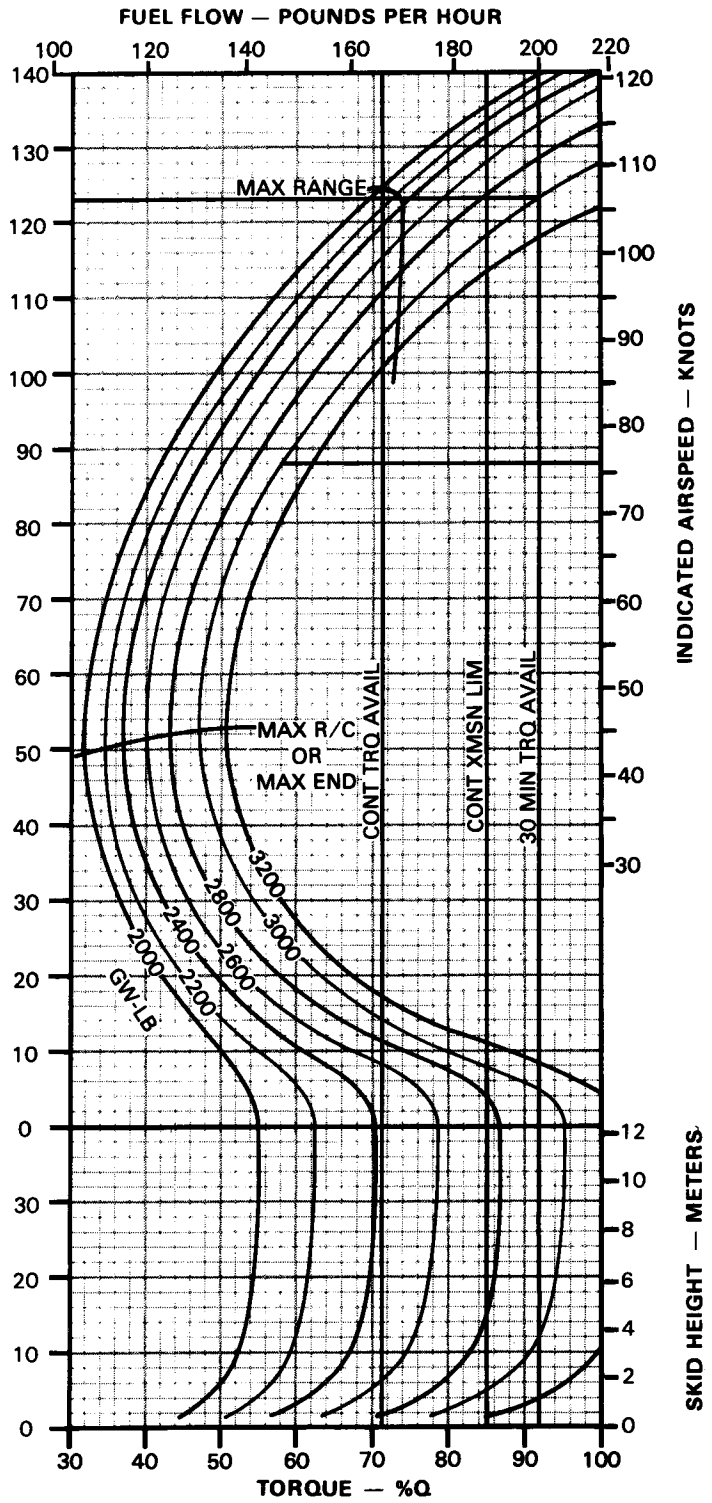
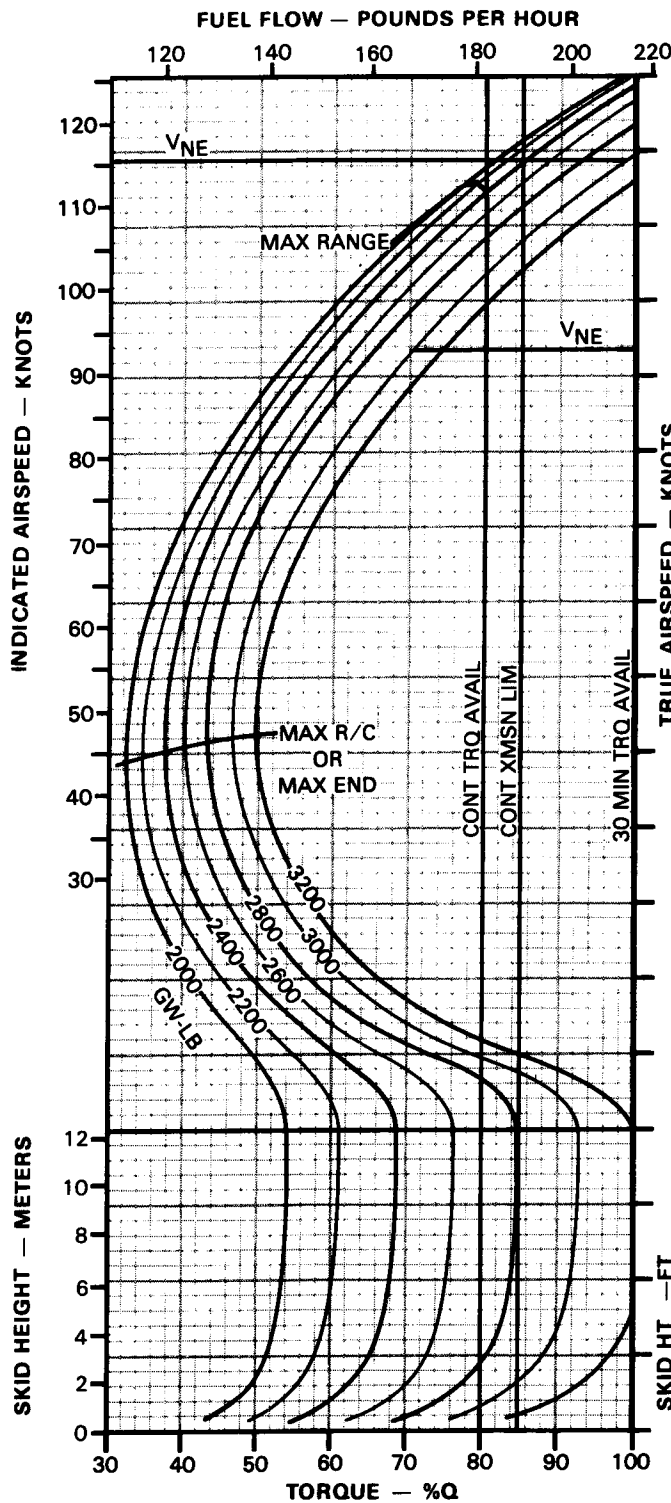



THIS IS AN UNCONTROLLED DOCUMENT. THE DATA IS PRESENTED FOR GENERAL INFORMATION ONLY. SOME INFORMATION HAS BEEN SUPERCEDED SINCE ORIGINAL PUBLICATION. PLEASE REFER TO THE CURRENT PRODUCT SPECIFICATION BOOKLET FOR UP-TO-DATE STANDARD EQUIPMENT LIST & KIT WEIGHTS, PERFORMANCE, AND DIRECT OPERATING COST.

BELL 206B JETRANGER III

CRUISE

PRESSURE ALTITUDE — 8000 TO 10000 FEET

CLEAN CONFIGURATION 100% RPM JP-4 FUEL

OAT WARMER THAN +30°C

8000 FEET
PRESSURE ALTITUDE

10000 FEET
PRESSURE ALTITUDE

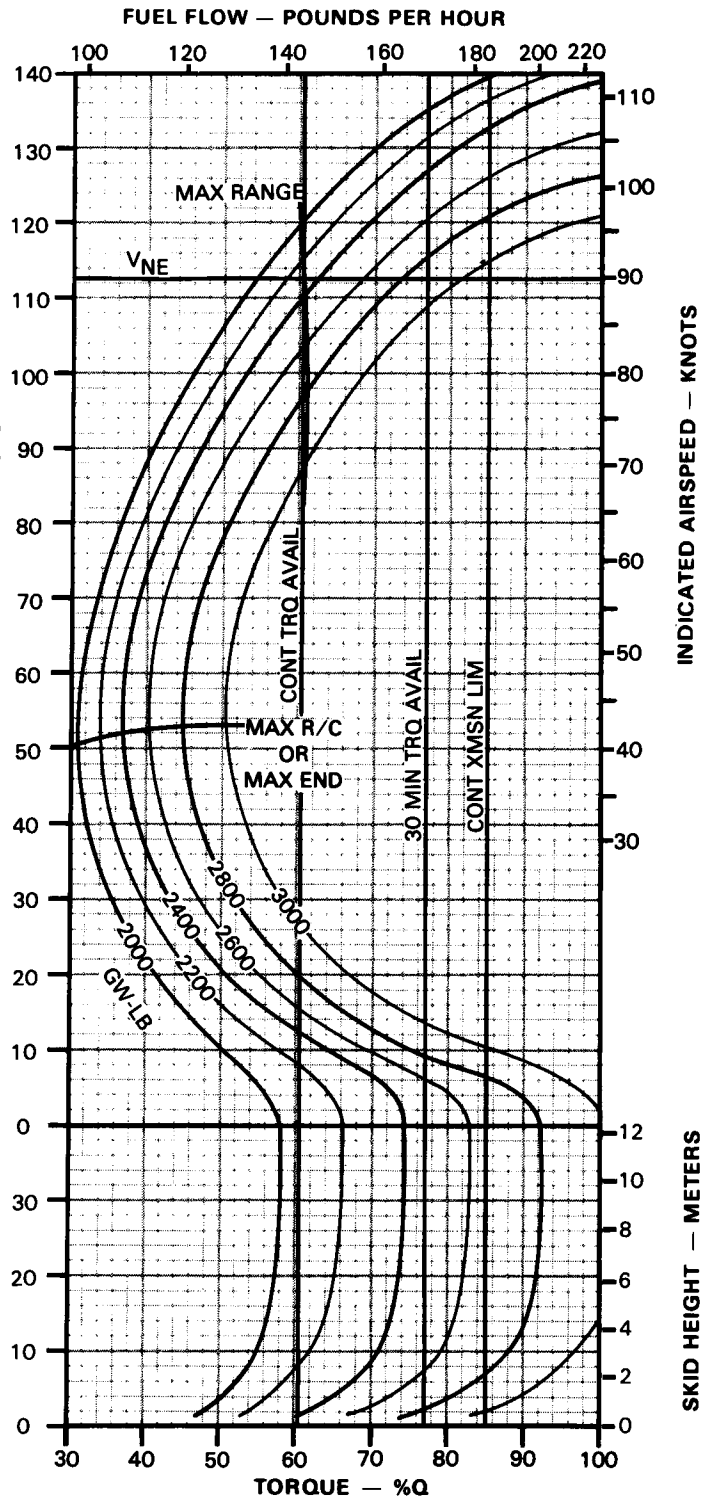
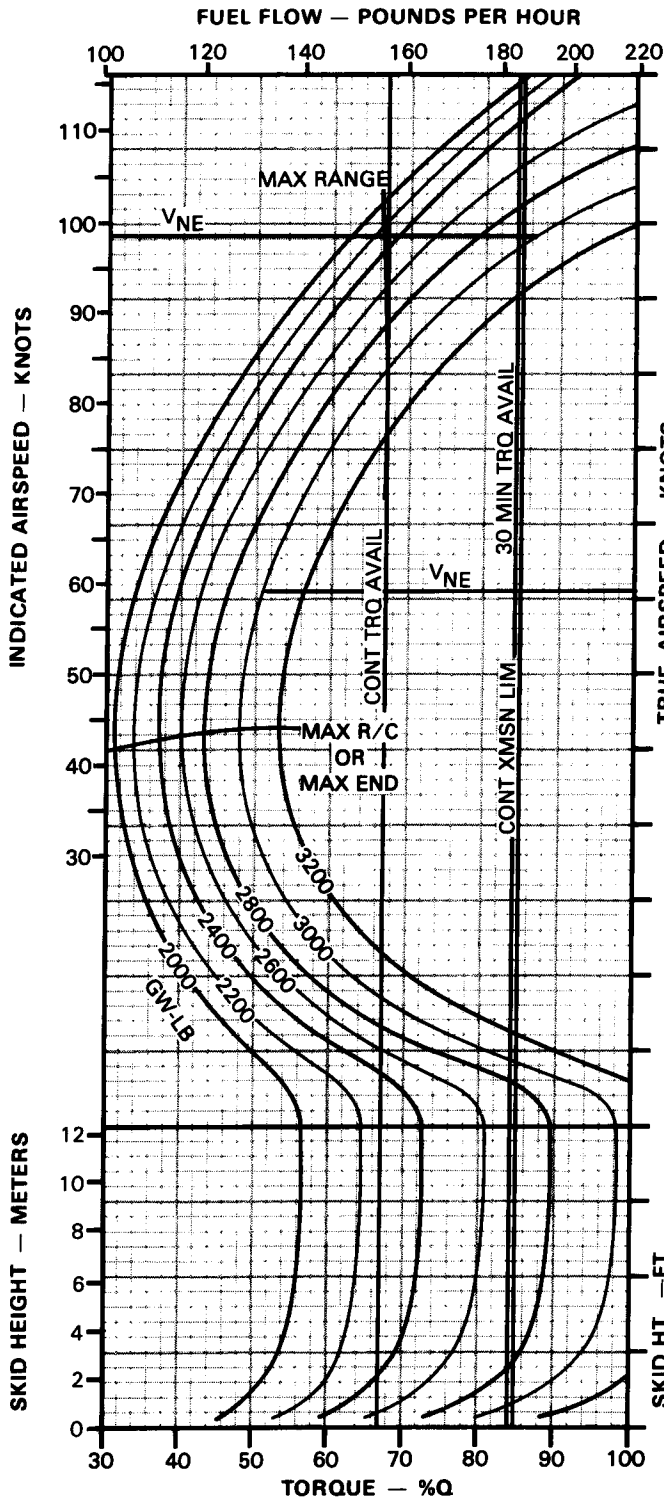

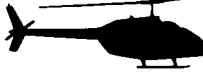

THIS IS AN UNCONTROLLED DOCUMENT. THE DATA IS PRESENTED FOR GENERAL INFORMATION ONLY. SOME INFORMATION HAS BEEN SUPERCEDED SINCE ORIGINAL PUBLICATION. PLEASE REFER TO THE CURRENT PRODUCT SPECIFICATION BOOKLET FOR UP-TO-DATE STANDARD EQUIPMENT LIST & KIT WEIGHTS, PERFORMANCE, AND DIRECT OPERATING COST.

BELL 206B JETRANGER III

CRUISE

PRESSURE ALTITUDE — 12000 TO 14000 FEET

CLEAN CONFIGURATION 100% RPM JP-4 FUEL

OAT WARMER THAN +30°C

12000 FEET
PRESSURE ALTITUDE

14000 FEET
PRESSURE ALTITUDE

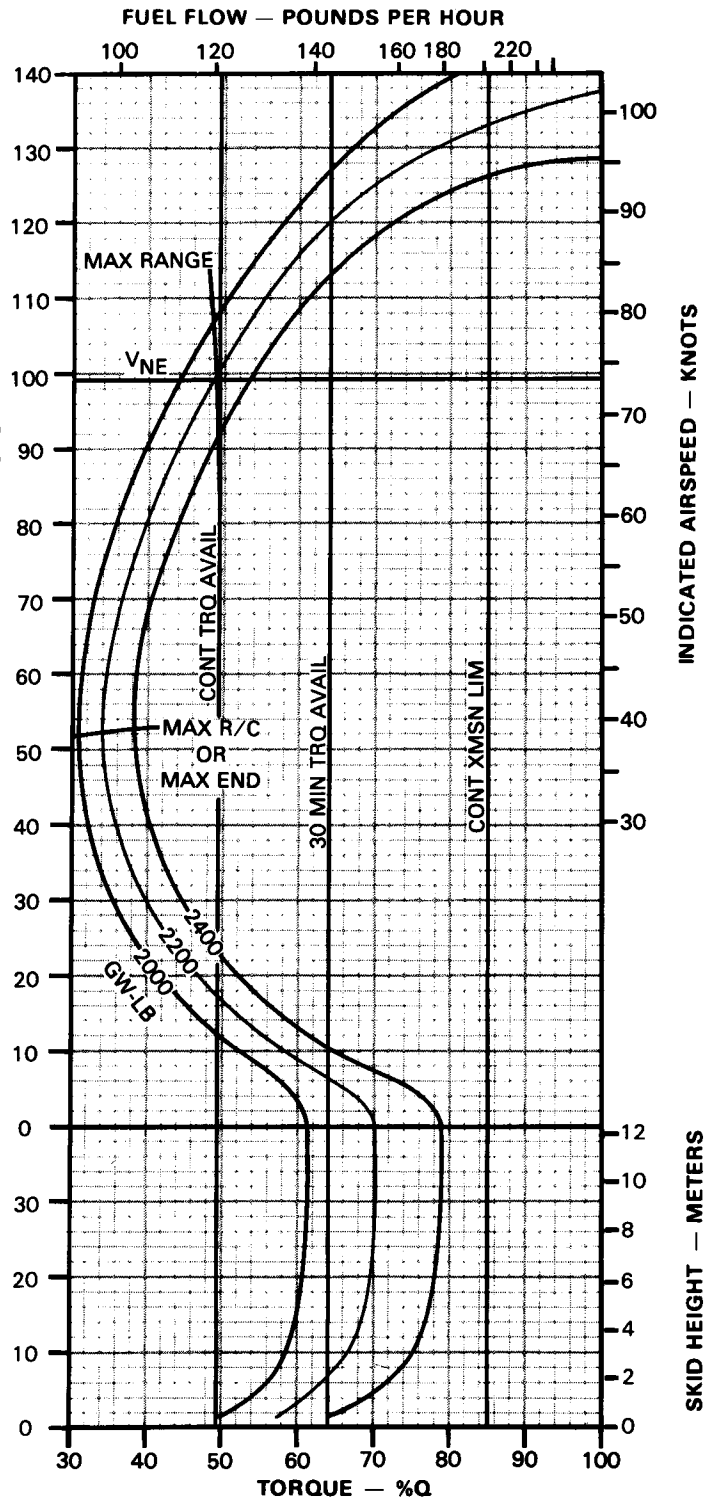
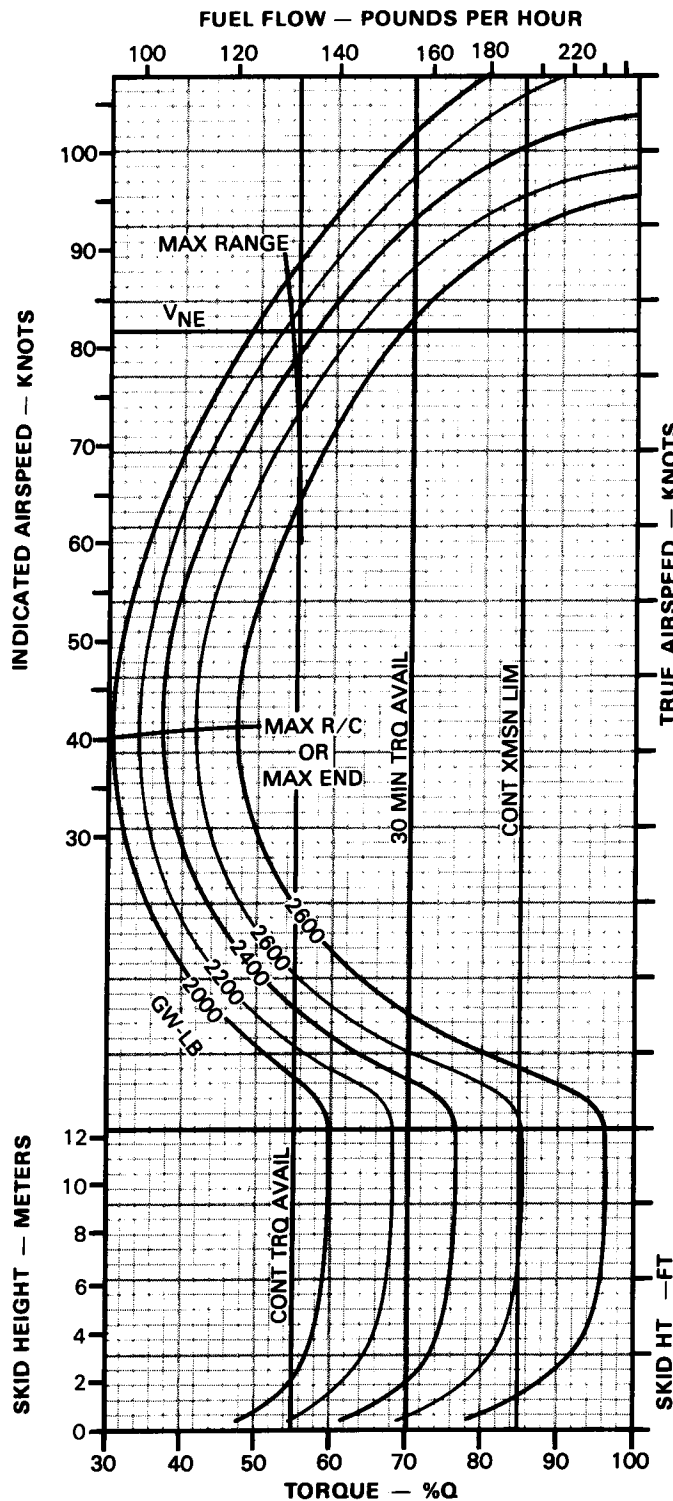

THIS IS AN UNCONTROLLED DOCUMENT. THE DATA IS PRESENTED FOR GENERAL INFORMATION ONLY. SOME INFORMATION HAS BEEN SUPERCEDED SINCE ORIGINAL PUBLICATION. PLEASE REFER TO THE CURRENT PRODUCT SPECIFICATION BOOKLET FOR UP-TO-DATE STANDARD EQUIPMENT LIST & KIT WEIGHTS, PERFORMANCE, AND DIRECT OPERATING COST.

THIS IS AN UNCONTROLLED DOCUMENT. THE DATA IS PRESENTED FOR GENERAL INFORMATION ONLY. SOME INFORMATION HAS BEEN SUPERCEDED SINCE ORIGINAL PUBLICATION. PLEASE REFER TO THE CURRENT PRODUCT SPECIFICATION BOOKLET FOR UP-TO-DATE STANDARD EQUIPMENT LIST & KIT WEIGHTS, PERFORMANCE, AND DIRECT OPERATING COST.

SECTION SEVEN

TYPICAL MISSIONS

BELL 206B, JETRANGER III



THIS IS AN UNCONTROLLED DOCUMENT. THE DATA IS PRESENTED FOR GENERAL INFORMATION ONLY. SOME INFORMATION HAS BEEN SUPERCEDED SINCE ORIGINAL PUBLICATION. PLEASE REFER TO THE CURRENT PRODUCT SPECIFICATION BOOKLET FOR UP-TO-DATE STANDARD EQUIPMENT LIST & KIT WEIGHTS, PERFORMANCE, AND DIRECT OPERATING COST.



MISSION PERFORMANCE

Since flight performance is directly related to the **total weight** of the helicopter, each individual mission configuration requires a weight review.

The standard JetRanger III is described and a weight is provided: 742 kilograms*. Three things must be added:

1. The pilot
2. Mission equipment and/or passengers
3. Sufficient fuel for the task

There are some limitations. The most important is the maximum weight or **gross weight**.

- 1452 kilograms for internal loads
- 1520 kilograms when at least 68 kilograms must be carried externally

Fuel is always a variable. It can be exchanged for cargo whenever the flight distance permits. Full usable fuel weighs 280 kilograms**.

From a weight point of view, the JetRanger III could be summarized as follows:

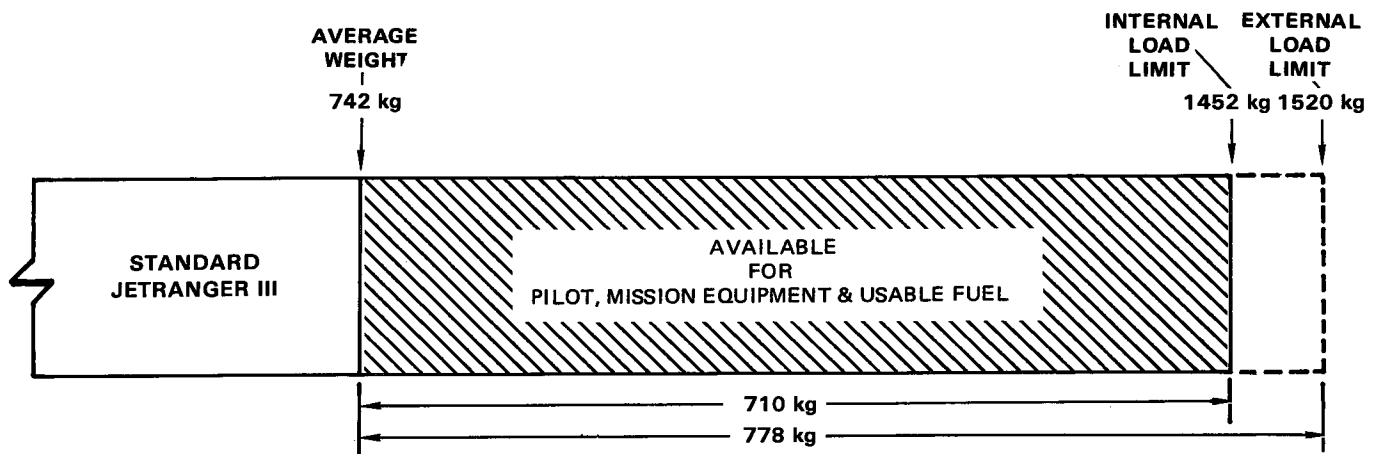

*The published weight includes all the equipment described in the standard configuration and 3.3 kilograms of unusable fuel. It does not include 5.9 kilograms of oil or ballast. Ballast is a function of installed optional equipment.

**Using Jet A (JP5) fuel at 0.815 kg/l at 15°C.

The data set forth in this brochure are general in nature and may vary with conditions. For performance data and operating limitations, for any specific flight mission, reference must be made to the approved flight manual.



THIS IS AN UNCONTROLLED DOCUMENT. THE DATA IS PRESENTED FOR GENERAL INFORMATION ONLY. SOME INFORMATION HAS BEEN SUPERCEDED SINCE ORIGINAL PUBLICATION. PLEASE REFER TO THE CURRENT PRODUCT SPECIFICATION BOOKLET FOR UP-TO-DATE STANDARD EQUIPMENT LIST & KIT WEIGHTS, PERFORMANCE, AND DIRECT OPERATING COST.

BELL 206B JETRANGER III

Add a pilot, oil and full fuel and it can still carry up to 347 kg mission equipment without exceeding the gross weight limitation.

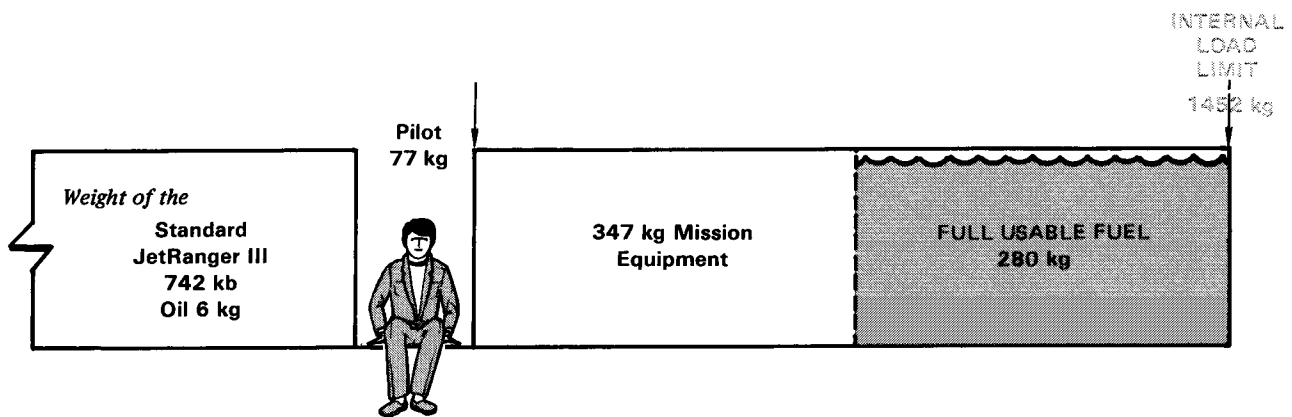

Having established the **mission weight**, the capability of the JetRanger III, equipped and ready for its task, depends on the density of the air; to be more precise, **pressure altitude and temperature**.

These two variables, pressure altitude and temperature, are fully covered in the performance graphs so that when the temperature and altitude are known, the weight that can be carried by the helicopter can be calculated.

The opposite is also true. Given the mission weight of the helicopter and the altitude, the temperature range within which the job can be accomplished can be determined.



The following chart shows what the JetRanger III can do when carrying a full load in three widely different temperatures.

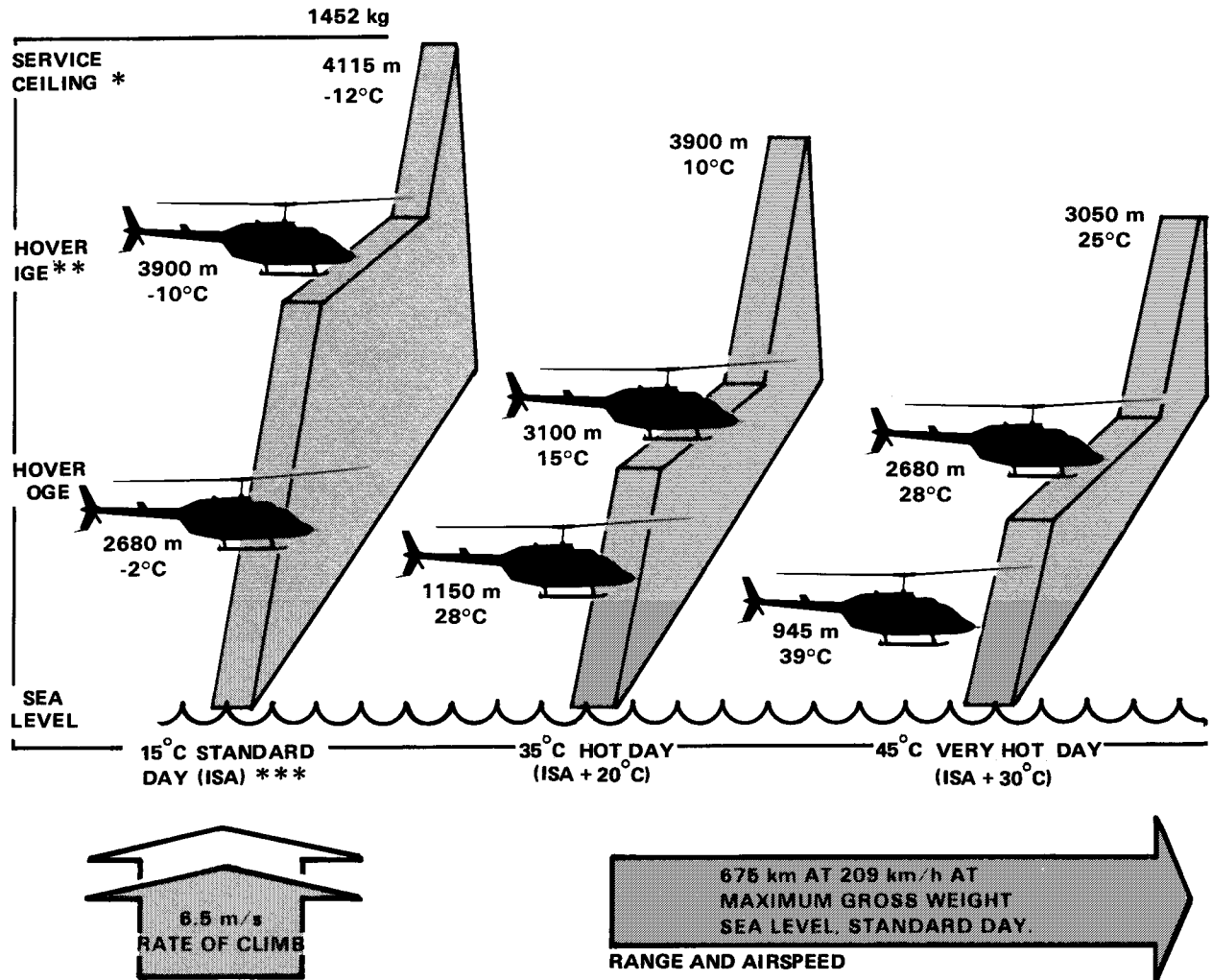

*Service ceiling is where the rate of climb is 30.5 m/min at maximum continuous power.

**The abbreviations OGE and IGE may not be familiar. A helicopter can hover completely away from or "out of" ground effect (OGE) - but when it can use the cushion of air that builds up when the helicopter is close to the ground, it can hover (and land) at a much higher altitude. This is known as "in ground effect" (IGE). It defines the altitude at which the helicopter can land and takeoff.

***ISA is the International Standard Atmosphere - a benchmark selected for world standardization.



THIS IS AN UNCONTROLLED DOCUMENT. THE DATA IS PRESENTED FOR GENERAL INFORMATION ONLY. SOME INFORMATION HAS BEEN SUPERCEDED SINCE ORIGINAL PUBLICATION. PLEASE REFER TO THE CURRENT PRODUCT SPECIFICATION BOOKLET FOR UP-TO-DATE STANDARD EQUIPMENT LIST & KIT WEIGHTS, PERFORMANCE, AND DIRECT OPERATING COST.

BELL 206B JETRANGER III

Mission weight is still the most important factor. At the same temperature, less weight can have a dramatic effect.

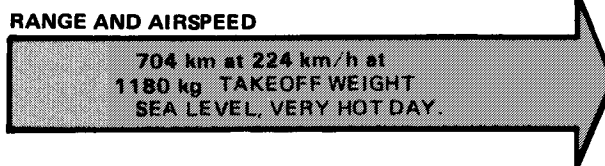
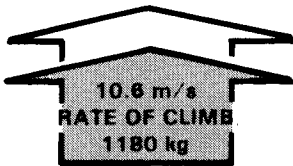
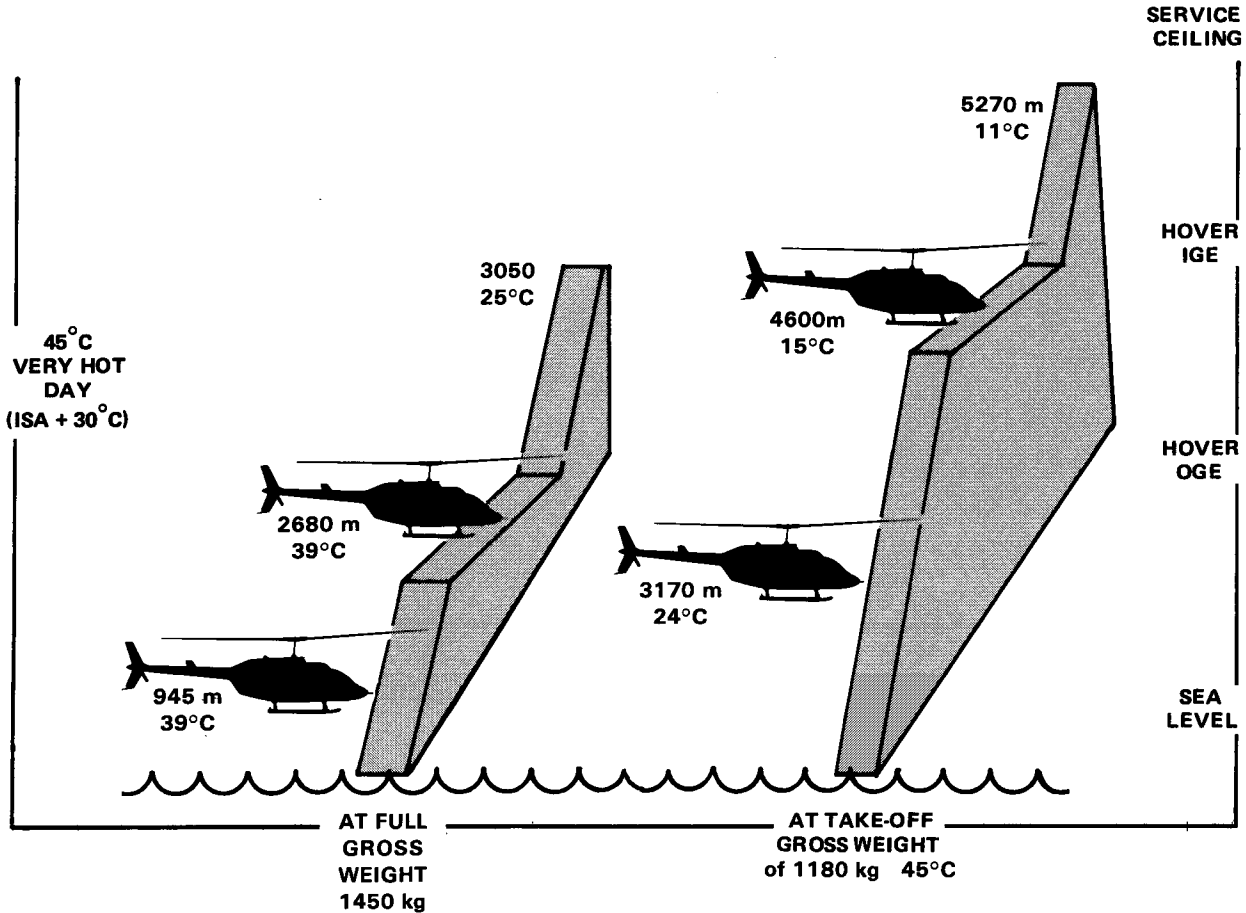

The speed selected for maximum endurance is listed in the tabulated performance as loiter speed.

At this speed the JetRanger III can remain airborne up to 4.9 hours.



Fuel required for the mission has two important factors. One is **cost**. The other is that **fuel is heavy** and if distance requirements are less than maximum, it can be traded off for more payload.

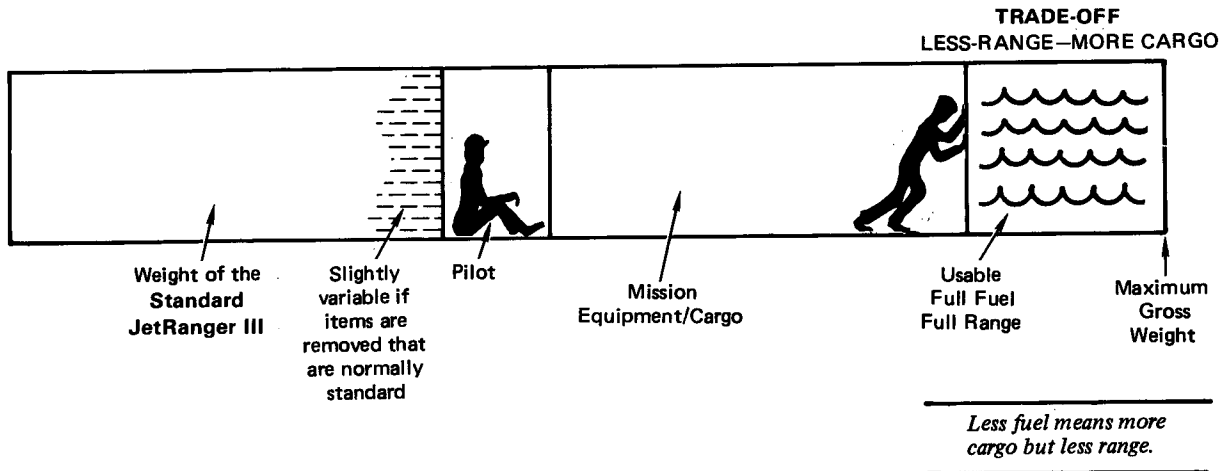

The JetRanger III travels approximately 2.44 km on a kilogram of fuel at full load on a hot day at sea level.

In fuel calculations, a reserve must be included - usually stated in minutes -

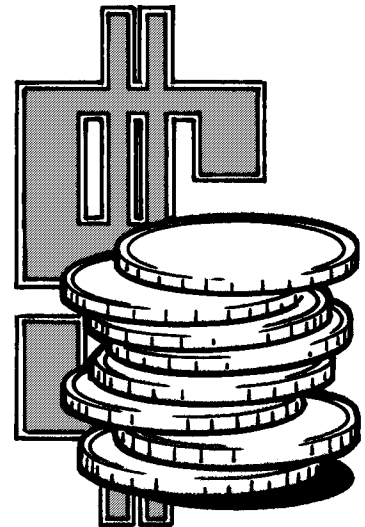



THIS IS AN UNCONTROLLED DOCUMENT. THE DATA IS PRESENTED FOR GENERAL INFORMATION ONLY. SOME INFORMATION HAS BEEN SUPERCEDED SINCE ORIGINAL PUBLICATION. PLEASE REFER TO THE CURRENT PRODUCT SPECIFICATION BOOKLET FOR UP-TO-DATE STANDARD EQUIPMENT LIST & KIT WEIGHTS, PERFORMANCE, AND DIRECT OPERATING COST.

BELL 206B
JETRANGER III



MISSION PERFORMANCE

Since flight performance is directly related to the **total weight** of the helicopter, each individual mission configuration requires a weight review.

The standard JetRanger III is described and a weight is provided: 1635 pounds*. Three things must be added:

1. The pilot
2. Mission equipment and/or passengers
3. Sufficient fuel for the task

There are some limitations. The most important is the maximum weight or **gross weight**.

- 3200 pounds for internal loads
- 3350 pounds when at least 150 pounds must be carried externally

Fuel is always a variable. It can be exchanged for cargo whenever the flight distance permits. Full usable fuel weighs 280 kilograms**.

From a weight point of view, the JetRanger III could be summarized as follows:

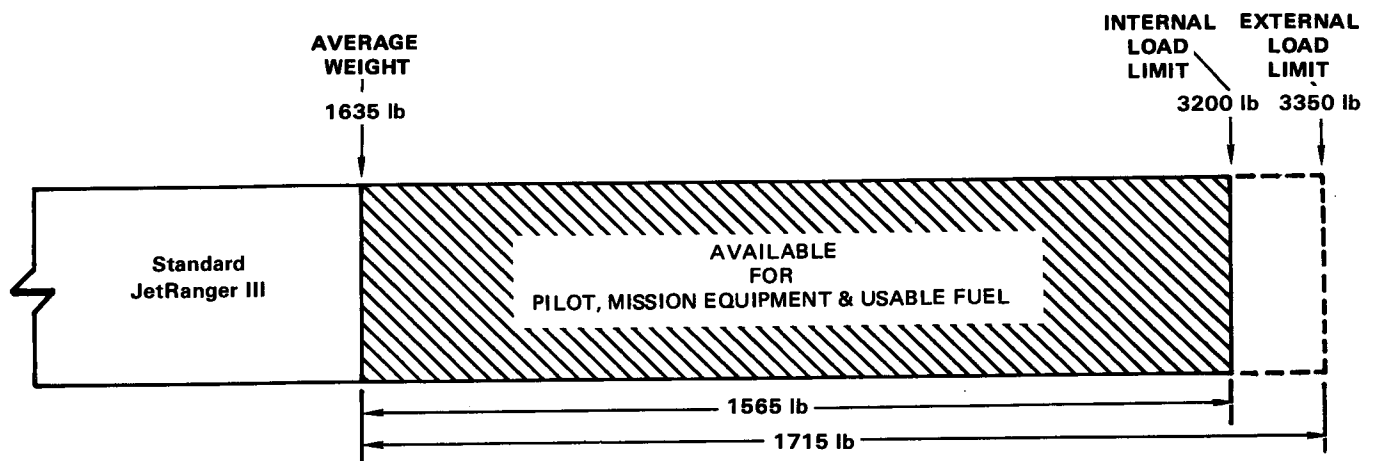

*The published weight includes all the equipment described in the standard configuration and 7 pounds of unusable fuel. It does not include 13 pounds of oil or ballast. Ballast is a function of installed optional equipment.

**Using Jet A (JP5) fuel at 0.815 kg/l at 15°C.

The data set forth in this brochure are general in nature and may vary with conditions. For performance data and operating limitations, for any specific flight mission, reference must be made to the approved flight manual.



THIS IS AN UNCONTROLLED DOCUMENT. THE DATA IS PRESENTED FOR GENERAL INFORMATION ONLY. SOME INFORMATION HAS BEEN SUPERCEDED SINCE ORIGINAL PUBLICATION. PLEASE REFER TO THE CURRENT PRODUCT SPECIFICATION BOOKLET FOR UP-TO-DATE STANDARD EQUIPMENT LIST & KIT WEIGHTS, PERFORMANCE, AND DIRECT OPERATING COST.

BELL 206B JETRANGER III

Add a pilot, oil and full fuel and it can still carry up to 763 lb mission equipment without exceeding the gross weight limitation.

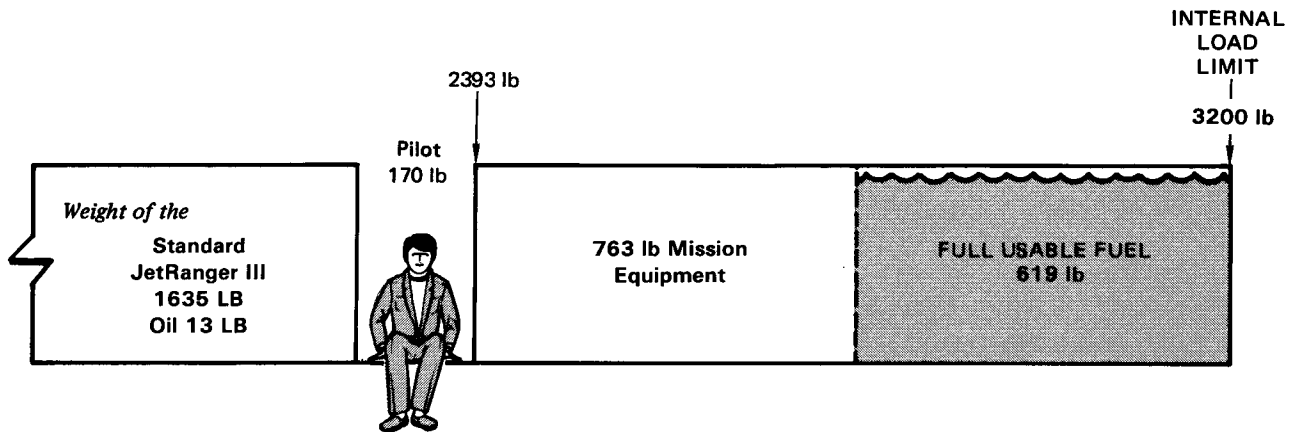

Having established the **mission weight**, the capability of the JetRanger III, equipped and ready for its task, depends on the density of the air; to be more precise, **pressure altitude and temperature**.

These two variables, pressure altitude and temperature, are fully covered in

the performance graphs so that when the temperature and altitude are known, the weight that can be carried by the helicopter can be calculated.

The opposite is also true. Given the mission weight of the helicopter and the altitude, the temperature range within which the job can be accomplished can be determined.

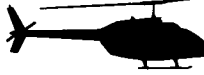

The following chart shows what the JetRanger III can do when carrying a full load in three widely different temperatures.

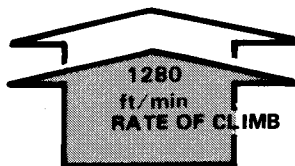
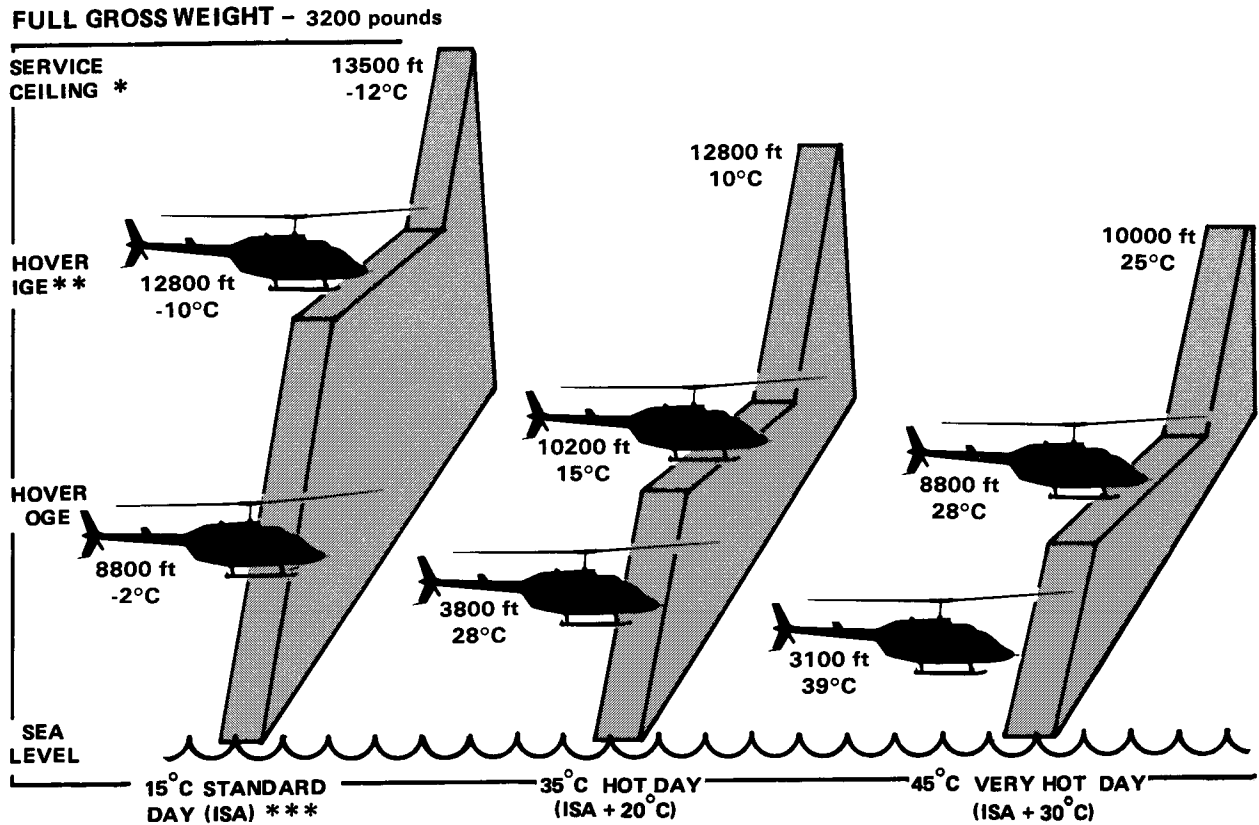

*Service ceiling is where the rate of climb is 30.5 m/min at maximum continuous power.

**The abbreviations OGE and IGE may not be familiar. A helicopter can hover completely away from or "out of" ground effect (OGE) - but when it can use the cushion of air that builds up when the helicopter is close to the ground, it can hover (and land) at a much higher altitude. This is known as "in ground effect" (IGE). It defines the altitude at which the helicopter can land and takeoff.

***ISA is the International Standard Atmosphere - a benchmark selected for world standardization.



THIS IS AN UNCONTROLLED DOCUMENT. THE DATA IS PRESENTED FOR GENERAL INFORMATION ONLY. SOME INFORMATION HAS BEEN SUPERCEDED SINCE ORIGINAL PUBLICATION. PLEASE REFER TO THE CURRENT PRODUCT SPECIFICATION BOOKLET FOR UP-TO-DATE STANDARD EQUIPMENT LIST & KIT WEIGHTS, PERFORMANCE, AND DIRECT OPERATING COST.

BELL 206B JETRANGER III

Mission weight is still the most important factor. At the same temperature, less weight can have a dramatic effect.

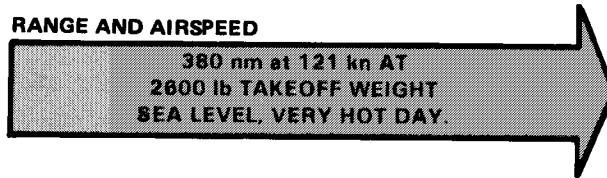
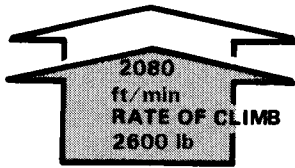
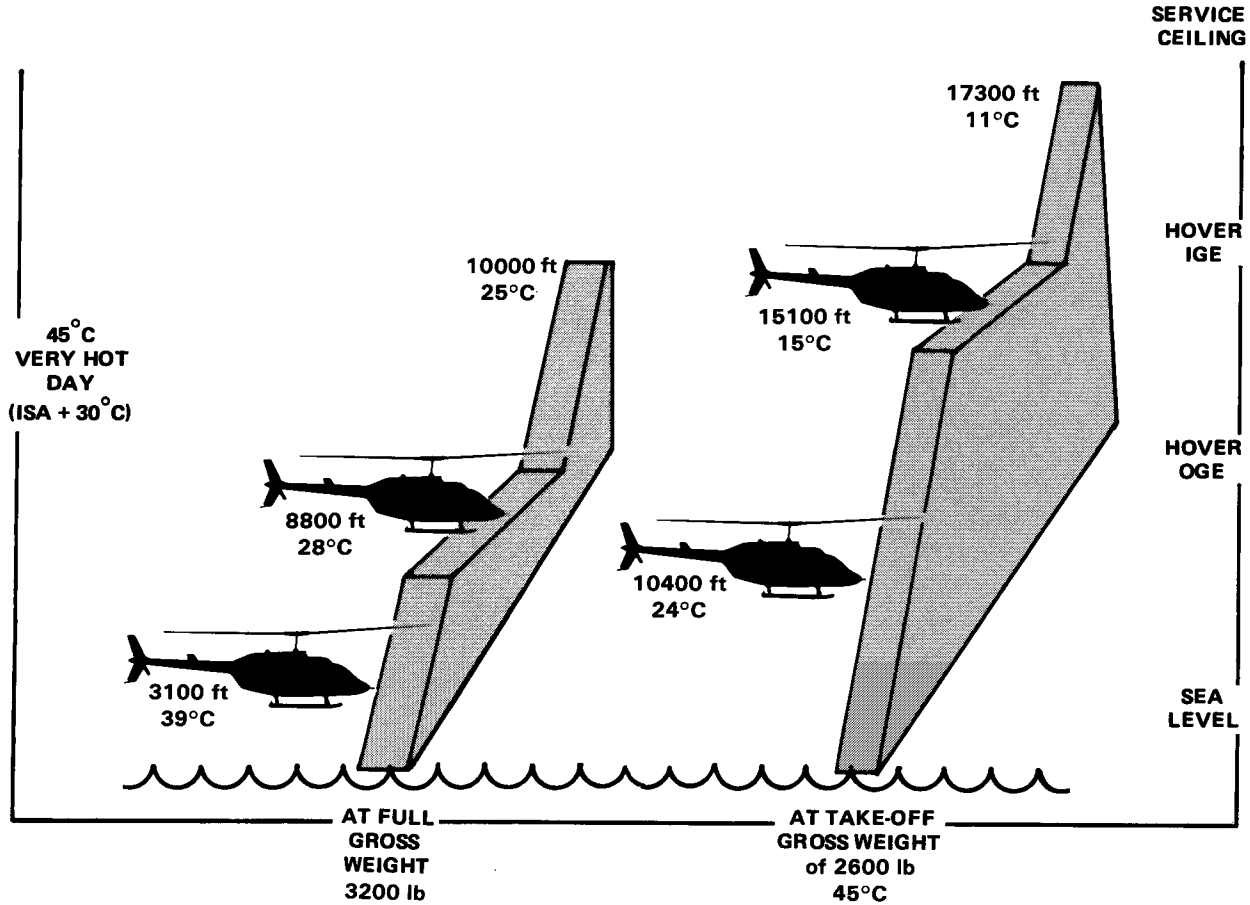

The speed selected for maximum endurance is listed in the tabulated performance as loiter speed.

At this speed the JetRanger III can remain airborne up to 4.9 hours.

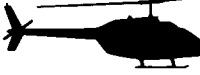

Fuel required for the mission has two important factors. One is **cost**. The other is that **fuel is heavy** and if distance requirements are less than maximum, it can be traded off for more payload.

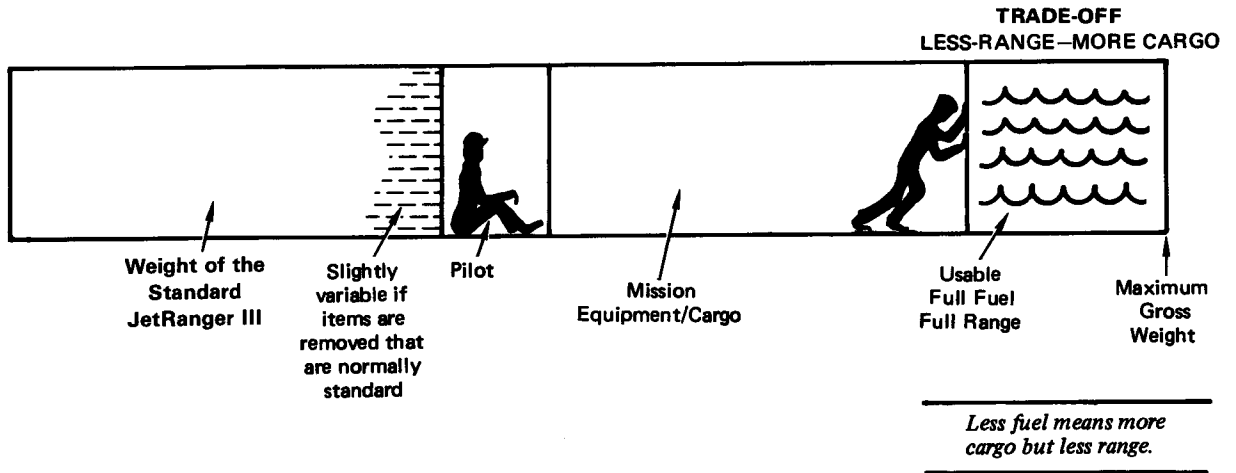

The JetRanger III travels approximately 0.59 nm on one pound of fuel at full load on a hot day at sea level.

In fuel calculations, a reserve must be included - usually stated in minutes -

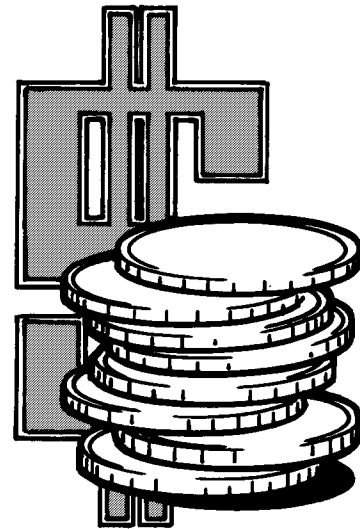



THIS IS AN UNCONTROLLED DOCUMENT. THE DATA IS PRESENTED FOR GENERAL INFORMATION ONLY. SOME INFORMATION HAS BEEN SUPERCEDED SINCE ORIGINAL PUBLICATION. PLEASE REFER TO THE CURRENT PRODUCT SPECIFICATION BOOKLET FOR UP-TO-DATE STANDARD EQUIPMENT LIST & KIT WEIGHTS, PERFORMANCE, AND DIRECT OPERATING COST.

BELL 206B
JETRANGER III



TYPICAL PEOPLE MOVER MISSION

One Pilot and Four Passengers
Utility Transport

Typical Mission Weight	kilograms	pounds
Standard JetRanger III With oil and unusable fuel	748.00	1,648.00
Optional Equipment:		
Rotor Brake	6.00	13.20
Particle Separator	3.00	6.50
Flight Instruments Group	4.40	9.60
VHF and Audio Panel	9.10	20.00
ADF	3.00	6.60
Transponder	1.68	3.72
ECS	39.50	87.00
 Pilot	 <u>77.00</u>	 <u>170.00</u>
	891.40	1,964.00
 Maximum Gross Weight	 1,452.00	 3,200.00
 Remaining for fuel and passengers	 560.60	 1,236.00
Four passengers @ 77 kg each (170 lb)	<u>308.00</u>	<u>680.00</u>
 Weight remaining for fuel (maximum usable fuel capacity 280 kg (619 lb))	 252.60	 556.00

On a hot day takeoff up to 3100 m altitude (10,200 ft)

With 258.6 kg (569 lb) fuel, the Jet-Ranger III with five adults on board operating at 2000 m (6500 ft) altitude can travel 630 kilometers (335.7 nm) (without reserve).

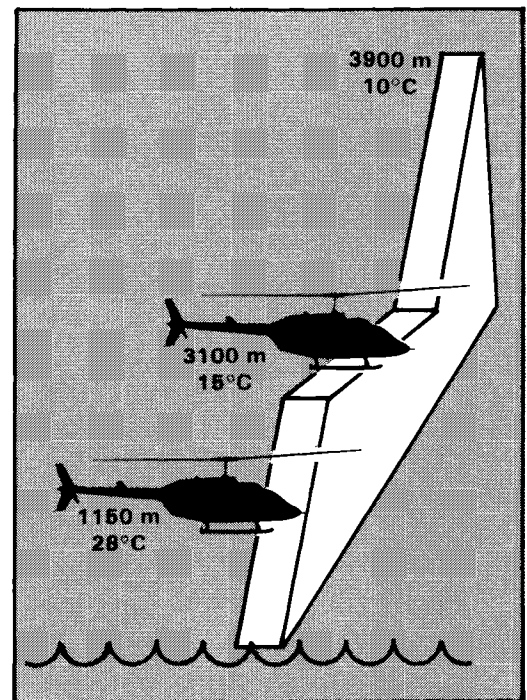



THIS IS AN UNCONTROLLED DOCUMENT. THE DATA IS PRESENTED FOR GENERAL INFORMATION ONLY. SOME INFORMATION HAS BEEN SUPERCEDED SINCE ORIGINAL PUBLICATION. PLEASE REFER TO THE CURRENT PRODUCT SPECIFICATION BOOKLET FOR UP-TO-DATE STANDARD EQUIPMENT LIST & KIT WEIGHTS, PERFORMANCE, AND DIRECT OPERATING COST.

**BELL 206B
JETRANGER III**

TYPICAL PEOPLE MOVER MISSION

Two Pilots and Three Passengers
Executive Transport

Typical Mission Weight	kilograms	pounds
Standard Configuration Weight with oil and Unusable Fuel	748.0	1,648.0
Optional Equipment:		
Dual Controls	4.0	8.9
Rotor Brake	6.0	13.2
Flight Instrument Group	4.4	9.6
Custom Soundproofing	10.9	24.0
Environmental Control System	39.5	87.0
Two KX 155 VHF Transceivers and KMA 24H Audio Panel	12.3	27.2
One KI 208 Course Deviation Indicator	0.5	1.0
One KR 87 KI 227 Automatic Direction Finder	3.0	6.6
One Pilot and Copilot	154.0	340.0
Three Passengers	231.0	510.0
Fuel	237.0	522.1
Takeoff Gross Weight	1,452.0	3,200.0

On a hot day (ISA+20°C) at a takeoff gross weight of 1,452 kg (3,200 lb), the JetRanger III travels 2.44 kilometers per kilogram of fuel (0.59 nm/lb) at an altitude of 1,800 m (6,000 ft). With 244 kilograms of fuel on board (537 lb), it can go 593 kilometers (316 nm) with no reserve at 217 km/h (117 kn) true airspeed. In 20 minutes it can travel 72 kilometers (39 nm). To provide 20 minutes reserve, the range would be reduced to 521 kilometers (277 nm).

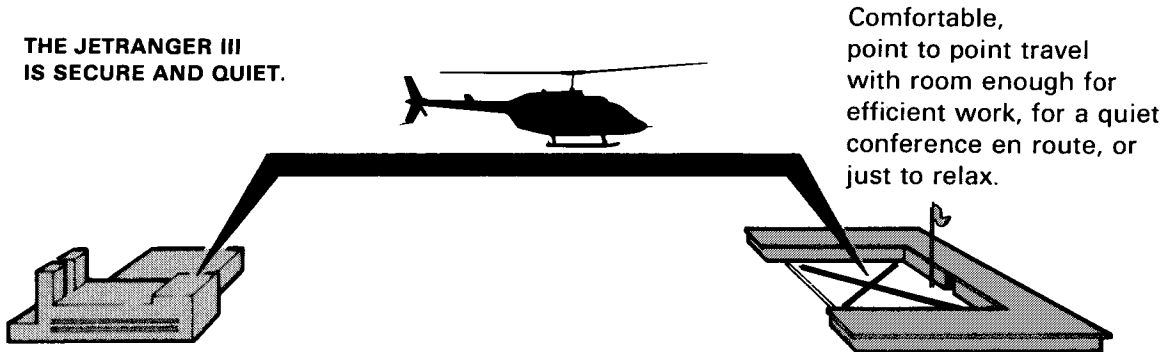

Cruise at 1800 meters (6000 ft) on a hot day for a distance of 521 kilometers (277 nautical miles), with 20 minutes reserve, at an airspeed of 217 kilometers per hour (117 kn), in 2 hours and 25 minutes.

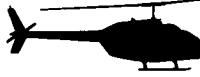

THIS IS AN UNCONTROLLED DOCUMENT. THE DATA IS PRESENTED FOR GENERAL INFORMATION ONLY. SOME INFORMATION HAS BEEN SUPERCEDED SINCE ORIGINAL PUBLICATION. PLEASE REFER TO THE CURRENT PRODUCT SPECIFICATION BOOKLET FOR UP-TO-DATE STANDARD EQUIPMENT LIST & KIT WEIGHTS, PERFORMANCE, AND DIRECT OPERATING COST.

BELL 206B JETRANGER III

TYPICAL CARGO MISSION

One Pilot
Economy Interior

Weight Statement	External Load Kilograms	Internal Load Kilograms
Standard Configuration Weight with Oil and Unusable Fuel	748.0	748.0
One KX 155 VHF Transceiver	9.1	9.1
Remove Interior	(18.0)	(18.0)
External Cargo Hook & Provisions	10.4	10.4
One Pilot	77.0	77.0
Fuel Plus Payload	692.0	624.0
Takeoff Gross Weight	1,520.0	1,452.0

External loads at 160 km/h
Internal loads at 185 km/h

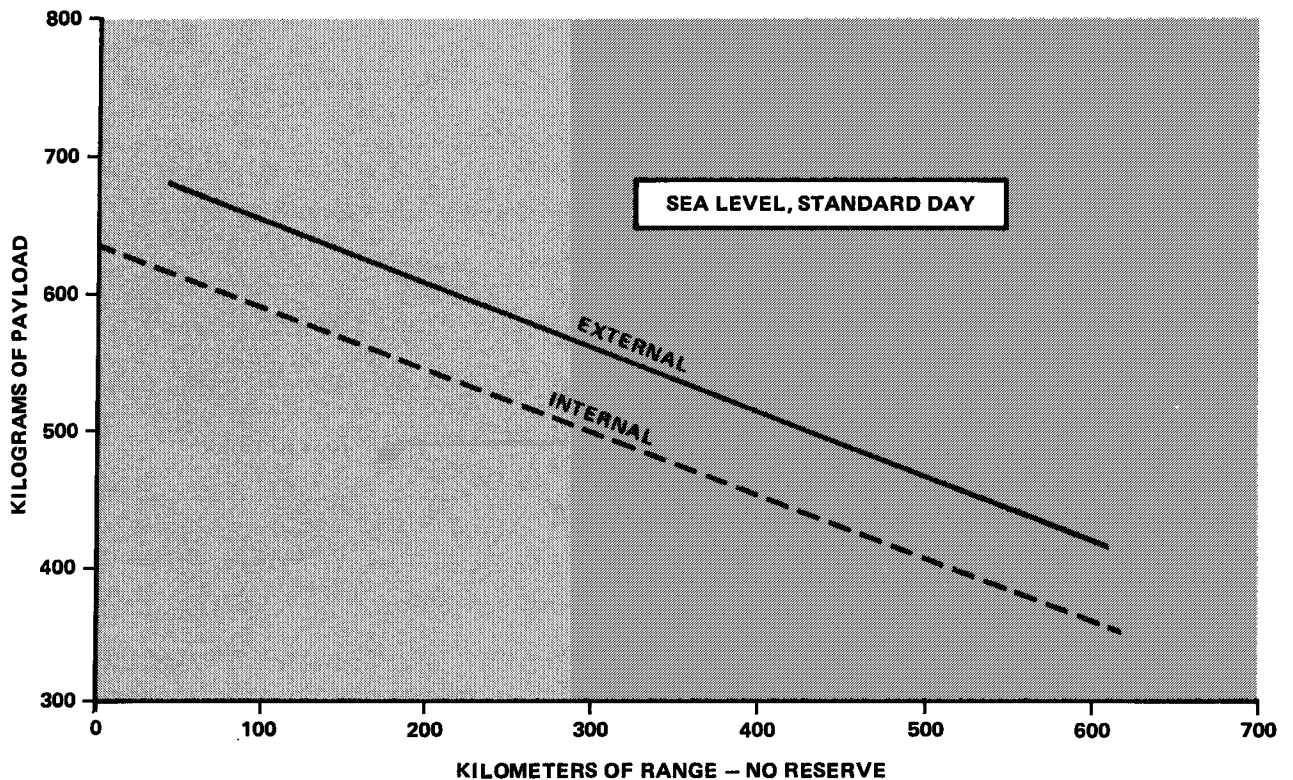



THIS IS AN UNCONTROLLED DOCUMENT. THE DATA IS PRESENTED FOR GENERAL INFORMATION ONLY. SOME INFORMATION HAS BEEN SUPERCEDED SINCE ORIGINAL PUBLICATION. PLEASE REFER TO THE CURRENT PRODUCT SPECIFICATION BOOKLET FOR UP-TO-DATE STANDARD EQUIPMENT LIST & KIT WEIGHTS, PERFORMANCE, AND DIRECT OPERATING COST.

**BELL 206B
JETRANGER III**

TYPICAL CARGO MISSION

One Pilot
Economy Interior

Weight Statement	External Load Pounds	Internal Load Pounds
Standard Configuration Weight with Oil and Unusable Fuel	1,648.0	1,648.0
One KX 155 VHF Transceiver	20.0	20.0
Remove Interior	(40.0)	(40.0)
External Cargo Hook	23.0	23.0
One Pilot	170.0	170.0
Fuel Plus Payload	1,526.0	1,376.0
Takeoff Gross Weight	3,350.0	3,200.0

External loads at 86 kn
Internal loads at 100 kn

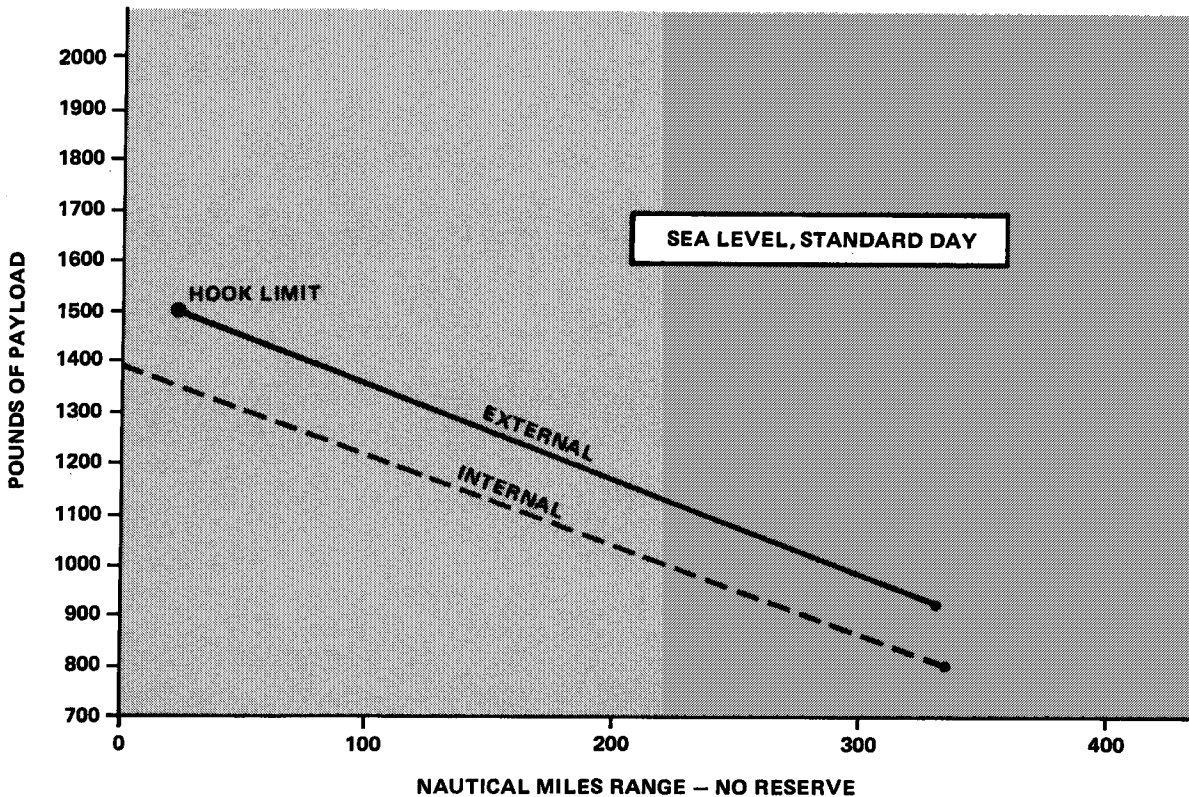

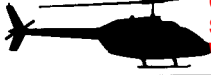

THIS IS AN UNCONTROLLED DOCUMENT. THE DATA IS PRESENTED FOR GENERAL INFORMATION ONLY. SOME INFORMATION HAS BEEN SUPERCEDED SINCE ORIGINAL PUBLICATION. PLEASE REFER TO THE CURRENT PRODUCT SPECIFICATION BOOKLET FOR UP-TO-DATE STANDARD EQUIPMENT LIST & KIT WEIGHTS, PERFORMANCE, AND DIRECT OPERATING COST.

**BELL 206B
JETRANGER III**

TYPICAL POWERLINE PATROL MISSION

One Pilot and Two Crewmembers
Standard Configuration With Infrared Camera

Weight Statement	Kilograms	Pounds
Standard Configuration Weight with Oil and Unusable Fuel	748.0	1,648.0
One KX 155 VHF Transceiver	9.1	20.0
Infrared Camera and Mount	20.0	44.0
One Pilot	77.0	170.0
One Crew Chief and One Operator	154.0	340.0
Full Fuel	280.0	619.0
Takeoff Gross Weight	1288.0	2,840.0

The JetRanger III has space to patrol efficiently, hour after hour

Cruise at 120 km/h (65 kn)
Distance covered 476 km (258 nm).
Land with 10% fuel reserve.

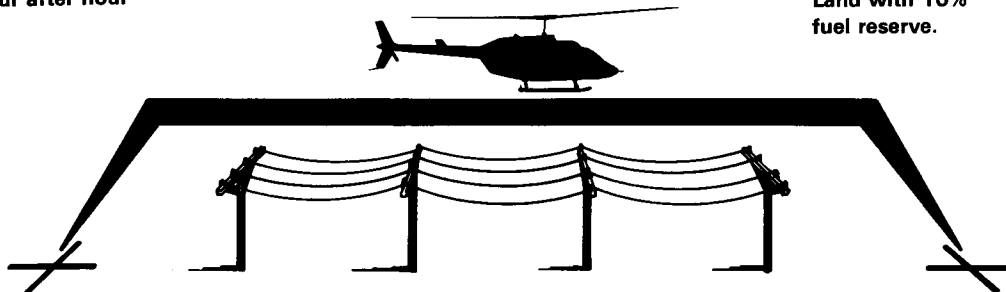

A roomy stable observation platform for direct inspection of every tower in any terrain.

THIS IS AN UNCONTROLLED DOCUMENT. THE DATA IS PRESENTED FOR GENERAL INFORMATION ONLY. SOME INFORMATION HAS BEEN SUPERCEDED SINCE ORIGINAL PUBLICATION. PLEASE REFER TO THE CURRENT PRODUCT SPECIFICATION BOOKLET FOR UP-TO-DATE STANDARD EQUIPMENT LIST & KIT WEIGHTS, PERFORMANCE, AND DIRECT OPERATING COST.

TYPICAL AERIAL AMBULANCE MISSION

One Pilot and Two Crewmembers
Standard Configuration With Emergency Equipment

Weight Statement	Kilograms	Pounds
Standard Configuration Weight with Oil and Unusable Fuel	748.00	1,648.00
Two KX 155 VHF Transceivers	12.30	27.20
One KI 208 Course Deviation Indicator	0.50	1.00
One KT 76A Transponder	1.68	3.72
Litter Kit	22.10	49.00
Advanced Lifesaving Equipment	79.00	175.00
Telemetry Equipment	9.00	20.00
One Pilot	77.00	170.00
Two Emergency Medical Technicians	154.00	340.00
Full Fuel	280.00	619.00
Takeoff Gross Weight	1384.00	3054.00

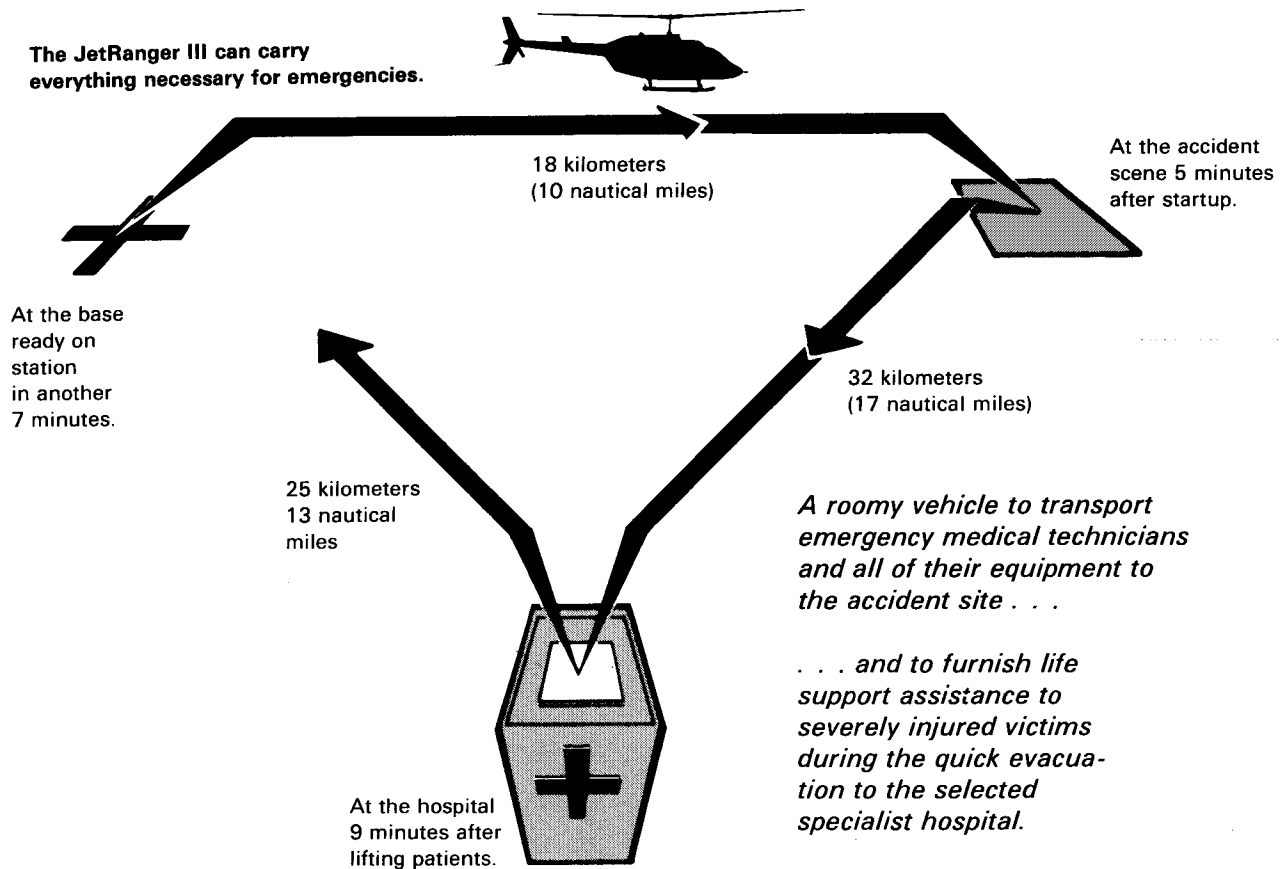

THIS IS AN UNCONTROLLED DOCUMENT. THE DATA IS PRESENTED FOR GENERAL INFORMATION ONLY. SOME INFORMATION HAS BEEN SUPERCEDED SINCE ORIGINAL PUBLICATION. PLEASE REFER TO THE CURRENT PRODUCT SPECIFICATION BOOKLET FOR UP-TO-DATE STANDARD EQUIPMENT LIST & KIT WEIGHTS, PERFORMANCE, AND DIRECT OPERATING COST.

SECTION EIGHT

TRAINING

BELL 206B, JETRANGER III



THIS IS AN UNCONTROLLED DOCUMENT. THE DATA IS PRESENTED FOR GENERAL INFORMATION ONLY. SOME INFORMATION HAS BEEN SUPERCEDED SINCE ORIGINAL PUBLICATION. PLEASE REFER TO THE CURRENT PRODUCT SPECIFICATION BOOKLET FOR UP-TO-DATE STANDARD EQUIPMENT LIST & KIT WEIGHTS, PERFORMANCE, AND DIRECT OPERATING COST.



GENERAL INFORMATION

In 1946, the helicopter was commercially certificated in the United States for the first time. The helicopter was a Bell. Since then the Bell Helicopter Training Center has offered the facilities, personnel and equipment to provide in-depth training in the theory, operation, maintenance and overhaul of all production models.

Classrooms are temperature controlled with ample space for effective use of multi-media presentations. The large shop area, also temperature controlled, is equipped with training aids consisting of actual helicopters, helicopter components, and operational "cutaway" mock-ups. The maintenance areas have the special tools and equipment required for specialized maintenance training. All courses make full use of modern audio/visual training aids. These include motion picture, video tape, overhead and 35mm projection. The texts for all courses are official Bell Helicopter Textron Inc. publications, supplemented by student notebooks which have been designed to follow the instructor's presentation and increase the student level of comprehension and retention. Instructor demonstrations and student shop exercises are conducted on the actual components, using associated test equipment. The amount of shop work scheduled for a particular course is determined by the level of training required, and the complexity of the component. The shop work is designed

to permit the student to experience, under supervision, the actual "on-the-job" exercise he will eventually face.

All supplies required for each training course are furnished by the Training Center and become the student's property.





The student's progress is carefully monitored and evaluated, giving the student immediate feedback of his progress.

Library and Learning Center

The Library and Learning Center is well stocked with up-to-date reference materials, audiovisual programs and films.

Modern equipment is provided in a quiet comfortable atmosphere where the student can learn at his own pace.

It is open daily.

Cafeteria

Students can use the Bell Cafeteria

located adjacent to the school in the Logistics Center.

Security

On the first day of training, students are issued a Training Center Identification Badge. The badge must be worn to gain entry to the Bell Cafeteria, but it will not permit entry to any other plant or facility at Bell.

Federal Security Regulations do not permit personal cameras, tape recorders, or firearms at Bell facilities.

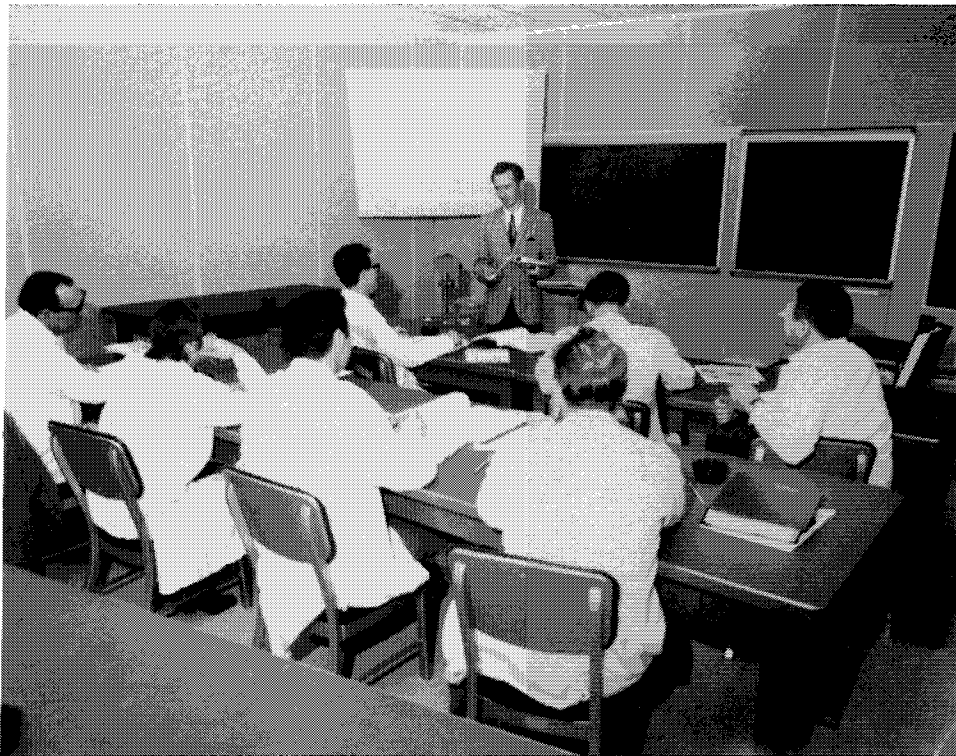

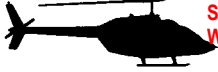

COMPLEMENTARY TRAINING

Bell Helicopter Textron Inc. provides helicopter training to purchasers of new JetRangers as follows:

PILOT TRANSITION

One current rotorcraft-rated pilot will be transitioned to the JetRanger.

The course consists of ground training and dual flight time in the customer's own helicopter.

The ground school portion of the course is scheduled to commence Monday each week. It is conducted in the classroom, the training shop and on the flight line. It is coordinated with flight instruction.

MECHANIC TRAINING

One mechanic will be trained. The course specially designed to do this is a two week Field Maintenance course. It can be scheduled within the period of six months prior to or six months following, the delivery of the JetRanger. After six months the option expires.

Classes for mechanics are conducted five days per week, Monday through Friday.

ADMINISTRATION

It is requested that the Training Center be advised of the intent to enroll as early as possible. Course schedules for available starting dates and class hours are available on request.

The following holidays are observed by Bell Helicopter Textron Inc. and its Training Center: New Year's Day, Good Friday, Memorial Day, July 4th, Labor Day, Thanksgiving Day, Friday after Thanksgiving, Christmas Eve and Christmas Day. Training time lost due to plant closings on scheduled holidays

will be made up during evening or Saturday sessions.

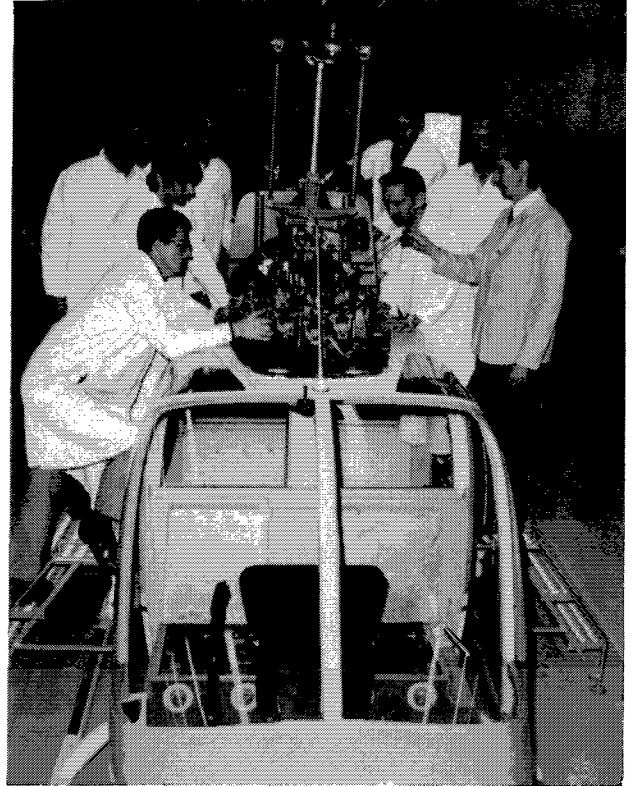

CLASS SIZE

Maximum:

The limiting factor will be the availability of trainers, shop hardware and special tools. Bell's Training Administration shall determine the maximum class size permissible to ensure qualifying standards.

Minimum:

Pilot Ground School - 2 students
Field Maintenance - 4 students

In the event these minimums are not met two weeks prior to scheduled start dates, the classes may be cancelled and students offered alternate dates.



BELL 206B
PILOT TRANSITION COURSE

COURSE LENGTH: 1 WEEK
(APPROXIMATE)
GROUND TRAINING: 20 HOURS
FLIGHT: 3 TO 5 HOURS

OBJECTIVE:

Ground Training:

Successful completion of the course will enable the qualified helicopter pilot to transition to the Bell 206B helicopter with comprehensive knowledge of the aircraft systems and components and a thorough understanding of the operational characteristics and flight limitations.

Flight Training:

To ensure complete knowledge of the current Bell 206B flight manual, to demonstrate and practice all flight maneuvers and to establish proficiency and safety in every phase of flight.

PREREQUISITES:

This course is specifically for helicopter pilots possessing current FAA cer-

tificates with appropriate ratings or the equivalent licenses issued by a foreign regulatory agency.

COURSE CONTENT:

Classroom presentations will cover the cockpit controls and instrumentation, airframe, power plant, and all aircraft systems. In addition, normal procedures, emergency procedures, operating limitations, and performance will be studied.

The flight transition includes complete familiarization of the Bell 206B helicopter, instruction in the turbine engine operation, and flight instruction in normal flight maneuvers and all emergency procedures. The emergency procedures include governor failure, hydraulic boost failure, touchdown autorotations and tail rotor failure.

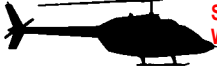

**BELL 206B FIELD MAINTENANCE
COURSE**

**COURSE LENGTH: 2 WEEKS
(80 HOURS)**

OBJECTIVE:

Upon successful completion, the student will be able to troubleshoot, inspect, perform or supervise the maintenance of the Bell 206B helicopter, up to but not including major repair or overhaul of the helicopter and its components.

Acceptable airworthiness techniques, procedures, and practices established by governing aviation authorities and Bell Helicopter Textron Inc. shall be used as satisfactory performance levels.

PREREQUISITES:

Students should meet one or more of the following skill and experience requirements.

1. Certification as an airframe mechanic with one year practical experience as a rated aircraft mechanic.

2. One year experience as an active mechanic on helicopters, commercial or military.

3. Three years general experience as a commercial or military aircraft mechanic.

COURSE CONTENT:

The course provides a comprehensive coverage of the description, function, and maintenance procedures required for field maintenance of the Bell 206B helicopter.

Classroom or shop work in the following areas will be covered: Airframe, Ground Handling and Servicing, Main Rotor, Mast, Rotating Controls, Transmission, Main Drive Shaft, Power Plant Interface (installation and rigging as related to the airframe), Fuel System, Tail Rotor, Tail Rotor Drive, Hydraulic System, Flight Controls, Electrical System, and Utility Systems.



THIS IS AN UNCONTROLLED DOCUMENT. THE DATA IS PRESENTED FOR GENERAL INFORMATION ONLY. SOME INFORMATION HAS BEEN SUPERCEDED SINCE ORIGINAL PUBLICATION. PLEASE REFER TO THE CURRENT PRODUCT SPECIFICATION BOOKLET FOR UP-TO-DATE STANDARD EQUIPMENT LIST & KIT WEIGHTS, PERFORMANCE, AND DIRECT OPERATING COST.

BELL 206B *JETRANGER III*

FOREIGN LANGUAGE CLASSES

All classes are taught in English. Any Bell Helicopter Textron Inc. Training Center courses that are required to be taught in a foreign language or through an interpreter are scheduled on an individual basis and must be prearranged.

In addition to the complementary training courses, others appropriate to the JetRanger are available. Typical examples are the external load course and the component overhaul course.





THIS IS AN UNCONTROLLED DOCUMENT. THE DATA IS PRESENTED FOR GENERAL INFORMATION ONLY. SOME INFORMATION HAS BEEN SUPERCEDED SINCE ORIGINAL PUBLICATION. PLEASE REFER TO THE CURRENT PRODUCT SPECIFICATION BOOKLET FOR UP-TO-DATE STANDARD EQUIPMENT LIST & KIT WEIGHTS, PERFORMANCE, AND DIRECT OPERATING COST.

BELL 206B
JETRANGER III

**ROTORCRAFT
EXTERNAL LOAD COURSE**

**COURSE LENGTH: 1 DAY
GROUND TRAINING: 2 HOURS
FLIGHT: 1 HOUR**

OBJECTIVES:

To ensure complete knowledge of FAR 133 pertaining to rotorcraft external load operation and to practice flight with an external load to assure maximum proficiency.

PREREQUISITES:

This course is designed specifically for helicopter pilots possessing current FAA certificates with appropriate ratings or the equivalent licenses issued by a foreign regulatory agency.

COURSE CONTENT:

The flight training will cover all operating limitations, operating procedures, and hand signals for external load operations. Flight will include hook-up and takeoff with an external load, approach to a designated spot utilizing electrical and manual release, and selection of flight routes when conducting external load operations.

An FAA check ride will be scheduled if requested.



BELL 206B
COMPONENT OVERHAUL COURSE

COURSE LENGTH: 1 WEEK
(40 HOURS)

OBJECTIVE:

Upon successful completion, the student will be able to troubleshoot, inspect, repair and overhaul the major components of the Bell 206B helicopter, but not including repair or overhaul of the airframe or powerplant.

Acceptable airworthiness techniques, procedures, and practices established by governing aviation authorities and Bell Helicopter Textron Inc. are used as satisfactory performance levels.

PREREQUISITES:

Students should meet one or more of the following skill and experience requirements:

1. Certification as an airframe mechanic with one year practical ex-

perience as a rated aircraft mechanic.

2. One year experience as an active mechanic on helicopters, commercial or military.
3. Three years general experience as a commercial or military aircraft mechanic.

COURSE CONTENT:

The course provides a comprehensive coverage of the description, function, maintenance and overhaul of the major components of the Bell 206B helicopter.

Classroom or shop work in the following areas will be covered: Main Rotor, Rotating Controls, Mast, Main Drive Shaft, Transmission, Tail Rotor Drive System and Tail Rotor.



ASSOCIATED COMPANY TRAINING CENTERS

It is suggested that training programs be arranged to provide for completion of pilot and maintenance courses at associated Training Centers and the Bell Helicopter Textron Inc. Training Center in order to coincide with helicopter delivery dates. The following manufacturers have established training departments providing familiarization, maintenance and overhaul instruction on their products.

ALLISON Detroit Diesel Allison
Sales and Service Training
P.O. Box 2206-B
Indianapolis, Indiana 46206
(317) 243-2586

COLLINS Training Department
RADIO Collins Radio Group
Rockwell International
144-100
Cedar Rapids, Iowa 52406
(319) 395-5523

GARRETT Field Service Training
Airesearch Mfg. Co.
2525 W. 190th St.
Torrance, California 90509
(213) 323-9500

HYDRAULIC Hydraulic Research &
RESEARCH Mfg. Co.
25200 West Rye Canyon
Road
Valencia, Calif. 91355
(805) 259-4030

We urge that you confirm your training schedule with them prior to finalizing your Bell Helicopter Textron Inc. class enrollment, and whenever possible, we recommend engine training be completed prior to Bell training to assure greater comprehension by the student.

THIS IS AN UNCONTROLLED DOCUMENT. THE DATA IS PRESENTED FOR GENERAL INFORMATION ONLY. SOME INFORMATION HAS BEEN SUPERCEDED SINCE ORIGINAL PUBLICATION. PLEASE REFER TO THE CURRENT PRODUCT SPECIFICATION BOOKLET FOR UP-TO-DATE STANDARD EQUIPMENT LIST & KIT WEIGHTS, PERFORMANCE, AND DIRECT OPERATING COST.

THIS IS AN UNCONTROLLED DOCUMENT. THE DATA IS PRESENTED FOR GENERAL INFORMATION ONLY. SOME INFORMATION HAS BEEN SUPERCEDED SINCE ORIGINAL PUBLICATION. PLEASE REFER TO THE CURRENT PRODUCT SPECIFICATION BOOKLET FOR UP-TO-DATE STANDARD EQUIPMENT LIST & KIT WEIGHTS, PERFORMANCE, AND DIRECT OPERATING COST.

SECTION NINE

ICES

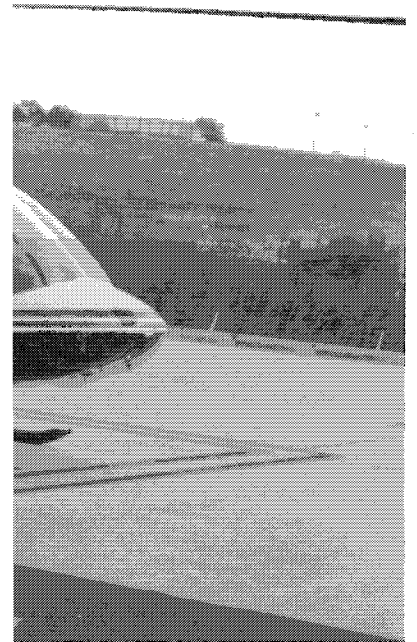

THIS IS AN UNCONTROLLED DOCUMENT. THE DATA IS PRESENTED FOR GENERAL INFORMATION ONLY. SOME INFORMATION HAS BEEN SUPERCEDED SINCE ORIGINAL PUBLICATION. PLEASE REFER TO THE CURRENT PRODUCT SPECIFICATION BOOKLET FOR UP-TO-DATE STANDARD EQUIPMENT LIST & KIT WEIGHTS, PERFORMANCE, AND DIRECT OPERATING COST.



CUSTOMER SUPPORT AND SERVICES DIVISION

Bell Helicopter Textron provides services to the users of its products through its Customer Support and Services Division (CSSD). All the functions necessary to satisfy user requirements are thus integrated.

There are six major groups reporting to the Vice President of the Division:

- Product Support
- Customer Supply Support
- Military Integrated Logistic Support
- Commercial Logistic Support
- Finance for the Division
- Administration

The Director of **Product Support** supervises Product Support Engineering, Commercial Field Service Representatives, Training Department and Technical Publications.

The Director of **Customer Supply Support** supervises the Spare Parts Department, Warehousing and Shipping Department, and the Bell Supply Centers.

The Manager of **Military Integrated Logistics Support** supervises the Spares Engineering Department, Logistical Support Analysis Group, and the Military Field Service Representatives.

The Manager of **Commercial Logistics Support** supervises Commercial Logistics Marketing, Customer Service Facilities and the Van Nuys Maintenance Facility.

The Controller for the Division supervises the **Finance Group** which consists of Contracts, Accounts Receivable, Warranty Administration and Budget.





The Manager of **Administration**, in addition to the administration of the Division, supervises the Visual Communications Center, both Motion and Still Photography, and the Operations Analysis Group.

PRODUCT SUPPORT

Product Support is of particular interest to the commercial customer. It functions as follows:

Product Support Engineering handles all technical correspondence received from the operators and Bell's Commercial Field Service Representatives. In order to furnish the information required for the replies, constant liaison is maintained with every department within Bell.

Product Support Engineering reviews the reports on field maintenance, serviceability of the equipment in general, and results of inspection reports for possible improvements which would result in savings to customers through reduced maintenance costs, fewer parts replacements or longer times between inspection periods.

Product Support Engineering also processes customer requests for warranty adjustments and monitors the processing of customers' property returned to Bell for repair or modification. A mailing list to provide customers with the appropriate technical publications and monitor Service Station Support Capability is maintained.

The Commercial Field Service Representatives (CSR) are technically oriented individuals permanently located at strategic points around the world.

These representatives are experienced in all Bell models and are kept current through an extensive training program. They are responsible to assist our customers in safety and cost of operations as well as technical and logistics support. They offer maintenance and operational assistance whenever required, including "on-the-job" training. This assistance is available during initial delivery, overhaul, special inspections or when the customer considers factory help is required. Periodic routine visits to the customer's base of operations are a part of the support program.

The CSRs act as intermediaries between the customer and technical staff in Fort Worth. They provide Product Support Engineering with field experience and data which is used for product improvement.

The CSRs provide information to our marketing organization concerning strengths and weaknesses of our products in relation to helicopters produced by other manufacturers.

The Training Department operates the Bell Helicopter Training Center. It provides pilot and mechanic training on all company equipment. The courses are of very high standard. They are flexible so that the customer receives the personal attention and scope of training he requires. (Pilot Transition Ground School for Bell's 222 and 412 is conducted by Flight Safety International, Inc. in their facility located adjacent to the Bell Helicopter Training Center.)



Maintenance and Overhaul courses are offered on all current models of Bell helicopters.

Technical Publications provides all the technical manuals and instructions required to effectively operate, service, maintain, inspect, repair and overhaul Bell equipment. It is the responsibility of Technical Publications to ascertain the full scope, complexity and significance of the problems involved in furnishing the technical information on a timely basis and in an adequate form to assure that the customer obtains the maximum use of his equipment.

Although it is the direct responsibility of Technical Publications to publish the various types of technical data, the content is reviewed as applicable by Product Support and/or Customer Supply Support to assure that the information contained in the text and the illustrations are consistent with current configurations. FAA approval is obtained prior to release of any technical data requiring such approval.

CUSTOMER SUPPLY SUPPORT

Customer Supply Support also has a direct impact on the customer.

The Spare Parts Department is stocked with a complete inventory to ensure prompt filling of the customer's orders. "Ship Grounded" orders are shipped within one day after receipt of the customer's order.

For the customer's convenience in preparing his stock inventory, several lists of recommended spare parts, covering a variety of operational situations, have been prepared, or our spare parts analysts will assist the customer to tailor an inventory to his needs. The lists are available on request.

Supply Centers have been established at Amsterdam the Netherlands; Calgary, Alberta, Canada; Naval Air Station, Milton, Florida; Montgomeryville, Pennsylvania; Ottawa, Ontario, Canada; and Van Nuys, California; to speed up the delivery of spares.

A copy of the 1982 Warranty follows.



Warranty

New Helicopters

Seller warrants each new helicopter to be free from defect in material and workmanship under normal use and service. Seller's obligation under this warranty is limited to replacement or repair of parts which are determined to Seller's reasonable satisfaction to have been defective within 2,000 hours of operation or two (2) years after delivery, whichever occurs first. Defective parts must be reported in writing to Seller's Warranty Administration within 90 days of being found defective. After 200 hours of use, there will be a prorated charge to the Purchaser for replacement (prorate the hours of total use against the then applicable part life of 2,000 hours, whichever is the lesser). Warranty adjustment is contingent upon the Purchaser complying with Seller's Warranty Administration disposition instructions for defective parts.

THIS WARRANTY IS GIVEN AND ACCEPTED IN PLACE OF (i) ALL OTHER WARRANTIES OR CONDITIONS, EXPRESS OR IMPLIED, INCLUDING BUT NOT LIMITED TO, THE IMPLIED WARRANTIES OR CONDITIONS OF MERCHANTABILITY AND FITNESS FOR PARTICULAR PURPOSE AND (ii) ANY OBLIGATION, LIABILITY, RIGHT, CLAIM OR REMEDY IN CONTRACT OR IN DELICT/TORT, INCLUDING PRODUCT LIABILITIES BASED UPON STRICT LIABILITY OR NEGLIGENCE, ACTUAL OR IMPUTED.

This warranty is the only warranty made by Seller. The remedies of Purchaser and obligations of Seller are limited to the repair or replacement of helicopter parts as provided herein. Seller excludes liability, whether as a result of a breach of contract or warranty, negligence or strict product liability, for incidental or consequential damages including without limitation, damage to the helicopter or other property, costs and expenses resulting from required changes or modifications to helicopter components and assemblies, changes in retirement lives and overhaul periods, and costs or expenses for commercial losses or lost profits due to loss of use or grounding of helicopters or otherwise.

Seller makes no warranty and disclaims all liability in contract or in delict/tort, including without limitation, negligence and strict delictual/tort liability, with respect to work performed by third parties at Purchaser's request and with respect to engines, engine accessories, batteries, radios, avionics, and Purchaser-furnished equipment or equipment manufactured by others and installed at Purchaser's request, except Seller assigns each manufacturer's warranty to Purchaser to the extent such manufacturer's warranty exists and is assignable.

This warranty shall not apply to any helicopter or part thereof which has been repaired or altered outside Seller's factory in any way so as, in Seller's judgment, to affect its stability, safety or reliability, or which has been subject to misuse, negligence or accident. No person, corporation or organization is authorized by Seller to assume for it any other liability in connection with the sale of its helicopters and parts.

Bell Helicopter **TEXTRON**
A Subsidiary of Textron Inc.
Bell Helicopter **TEXTRON**
A Division of Textron Canada Ltd.

Warranty Administration
January 1, 1988



**KEY POINTS OF YOUR
BELL HELICOPTER
TEXTRON WARRANTY**

1. Bell Helicopter Textron (BHT) warranty is for one year or 1,000 hours, whichever comes first.
2. After 200 hours, warranty credit is prorated against a 2,000 hour service life or the scheduled retirement life or the scheduled retirement life of the defective part, whichever is the lesser. (See proration schedule.)
3. BHT's obligation is to replace or repair parts.
4. Transportation charges for return of defective part which has been replaced under warranty will be reimbursed by BHT only when BHT directs the buyer to return the defective part.
5. Warranty on engines, engine accessories, battery, radio and navigation equipment will be handled directly by their manufacturers.
6. This warranty attaches to the helicopter and is transferable by the owner.
7. Excluded from BHT warranty coverage are:
 - A. Incidental and consequential damages including, without limitation, damage to the helicopter or other property.
 - B. Costs resulting from changes or modifications.
 - C. Costs resulting from changes in retirement lives and overhaul periods.
 - D. Costs for commercial losses or lost profits due to loss of use.
 - E. Unauthorized repair, alterations or installation.
 - F. Labor costs for removal and installation of defective part.



**WARRANTY CREDIT FOR
REPLACEMENT PART**

This BHT warranty is for one year or 1,000 hours, whichever comes first. This BHT warranty provides 100% coverage for the first 200 hours.

After 200 hours of use, charges to purchaser for such replacement shall be prorated for hours of total use against the then applicable part life or 2,000 hours, whichever is the lesser.

Formula for computing warranty on parts with a retirement life of less than 2,000 hours:

$$100\% - \frac{TT-200}{RT-200} \times IC = W$$

- TT = TOTAL TIME ON PART
- RT = SCHEDULED RETIREMENT LIFE OF THE PART
- IC = BHT INVOICED COST OF THE REPLACEMENT
- W = WARRANTY CREDIT

Use this schedule for part on conditions or with retirement life exceeding 2,000 hours.

Part Time in Hours vs. % Credit (Paid to Next Higher %)

Hours		Hours		Hours	
0-200	100%	488	84%	776	68%
218	99%	506	83%	794	67%
236	98%	524	82%	812	66%
254	97%	542	81%	830	65%
272	96%	560	80%	848	64%
290	95%	578	79%	866	63%
308	94%	596	78%	884	62%
326	93%	614	77%	902	61%
344	92%	632	76%	920	60%
362	91%	650	75%	938	59%
380	90%	668	74%	956	58%
398	89%	686	73%	974	57%
416	88%	704	72%	992	56%
434	87%	722	71%	1,000	56%
452	86%	740	70%	1,001	0%
470	85%	758	69%		

Credit for parts replaced will be based on the BHT invoiced cost of the replacement parts.

Parts which are repaired and returned to service are covered for 100% of the repair cost.

THIS IS AN UNCONTROLLED DOCUMENT. THE DATA IS PRESENTED FOR GENERAL INFORMATION ONLY. SOME INFORMATION HAS BEEN SUPERCEDED SINCE ORIGINAL PUBLICATION. PLEASE REFER TO THE CURRENT PRODUCT SPECIFICATION BOOKLET FOR UP-TO-DATE STANDARD EQUIPMENT LIST & KIT WEIGHTS, PERFORMANCE, AND DIRECT OPERATING COST.

SECTION TEN

COST OF OPERATIONS

BELL 206B, JETRANGER III



THIS IS AN UNCONTROLLED DOCUMENT. THE DATA IS PRESENTED FOR GENERAL INFORMATION ONLY. SOME INFORMATION HAS BEEN SUPERCEDED SINCE ORIGINAL PUBLICATION. PLEASE REFER TO THE CURRENT PRODUCT SPECIFICATION BOOKLET FOR UP-TO-DATE STANDARD EQUIPMENT LIST & KIT WEIGHTS, PERFORMANCE, AND DIRECT OPERATING COST.



COST OF OPERATIONS

The following cost of operations data is based upon actual cost information from Bell operators and service facilities.

Bell's Customer Support organization accumulated the data base from a **diverse group** - large, small - sub-polar, sub-tropical - inland, coastal - corporate, charter - over all seasons, to produce a sound average of the **field experience** on the JetRanger. It continues to collect data to maintain currency.

There are three costs involved:

- **cost of ownership**
- **direct costs** of operation
- **indirect costs** of operation

The **direct costs** are those which are incurred essentially by the flight hour and include:

- Fuel, lubricants
- Basic airframe maintenance
- Power plant maintenance

The **indirect costs** are directly dependent upon the number of hours flown, and include:

- Insurance
- Facilities (hangar, workshop, etc.)
- Crew compensation
- Financial factors (depreciation, investment tax credit, financing costs, etc.)

A sample of typical direct costs for the 206B JetRanger III follows. Bell can assist in detailed estimates relating to specific applications.



SAMPLE - COST OF OPERATIONS
DOLLARS PER FLIGHT HOUR

Operator
Overhaul

Fuel and Lubricants

Fuel: (**Note 1**) [28 Gal/Hr] \$42.00

Lubricants: 3% of Fuel Cost 1.26

Airframe Direct Maintenance

Labor: (*Note 2*)

Inspection (0.22 MH/FH) 11.15

Overhaul (0.10 MH/FH) 5.00

Unscheduled and on-condition (0.37 MH/FH) 18.33

Parts:

Inspections 3.55

Overhaul 12.54

Retirement 28.44

Unscheduled and on-condition 28.96

Powerplant Direct Maintenance

Overhaul (Including Accessories) 42.07

Line Maintenance (parts and labor) 3.00

TOTAL AVERAGE COST / HR

\$196.18

Note 1: Fuel at \$1.50 per gallon. Average fuel consumption for LRC at 1000 feet, ISA,
(Jet-A at 6.8 Lb/Gal.)

Note 2: Labor rate assumed at \$50.00 per hour.



DIRECT COSTS

Notes on the sample data:

Fuel, Lubricants

Fuel at \$0.40 per liter (\$1.50 per gallon) and lubricants at 3% fuel cost are used as typical average values.

Fuel pricing varies considerably based on where the fuel is purchased geographically and whether it is purchased retail or in bulk.

Fuel consumption depends upon speed, altitude, temperature, externally-mounted accessories, sling loads, etc. A band of approximately 10 percent more or less than the sample value will cover these factors for normal operations.

Basic Airframe Maintenance

Airframe maintenance is divided into four categories:

- Periodic inspections
- Overhauls
- Replacement of retirement parts
- Unscheduled

Periodic inspections include those inspection tasks, with their parts requirements, listed in the Maintenance Manual.

Man-hours for periodic inspections can vary from the sample values because of differences in personnel experience, tool and parts availability, facilities,

environmental effects such as extremes in working temperatures. Man-hour costs/hour are also variable among the Authorized Service Centers as a result of differences in local costs, overhead expenses and volume of work. The sample value of \$50 per hour is an average of costs per hour at authorized Service Centers at the time of publication.

Overhauls include removal, disassembly, inspection, parts replacement, re-assembly and reinstallation of certain components/assemblies at the periods stated in the Maintenance Manual.

Overhaul man-hour and parts requirements are subject to considerable variations depending upon the helicopter's operations and environment. The sample data reflect average values.

Retirement parts are those which are subject to disposal after an operating time stated in the Maintenance Manual. These are normally components of the rotors/control systems which are subject to oscillatory loads and are designed and tested for use over a finite number of flight hours rather than on their condition. Their replacement at the required intervals requires some labor which is included in the man-hour data in the sample.

The following table lists the Limited Life Items and the Component Overhaul Intervals.



THIS IS AN UNCONTROLLED DOCUMENT. THE DATA IS PRESENTED FOR GENERAL INFORMATION ONLY. SOME INFORMATION HAS BEEN SUPERCEDED SINCE ORIGINAL PUBLICATION. PLEASE REFER TO THE CURRENT PRODUCT SPECIFICATION BOOKLET FOR UP-TO-DATE STANDARD EQUIPMENT LIST & KIT WEIGHTS, PERFORMANCE, AND DIRECT OPERATING COST.

**BELL 206B
JETRANGER III**

LIFE LIMITED COMPONENTS

PART NUMBER	NOMENCLATURE	LIFE	QTY PER A/C	LIST PRICE (EA)	COST PER FLIGHT HOUR
206-010-200-133	Main Rotor Blade	5,000	2	\$25,112	\$10.04
206-011-113-103	Main Rotor Trunnion	4,800	1	\$1,821	\$0.38
206-011-125-105	Main Rotor Strap Pin	2,500	2	\$307	\$0.25
206-011-132-113A	Main Rotor Grip	4,800	2	\$6,066	\$2.53
206-011-150-105	Retention Strap Fitting	2,400	2	\$1,366	\$1.14
206-011-154-107	Tension-Torsion Strap	1,200	2	\$2,944	\$4.91
206-011-260-103	Retention Strap Bolt	2,500	2	\$522	\$0.42
206-001-194-001	Lower Collective Tube	4,800	1	\$566	\$0.12
206-001-566-101	Servo Actuator Support	10,000	1	\$9,360	\$0.94
206-010-407-001	Collective Lever Idler Link	4,800	1	\$708	\$0.15
206-010-452-113	Swashplate Support	4,800	1	\$5,063	\$1.05
206-010-454-109	Swashplate Sleeve Assy	4,800	1	\$2,718	\$0.57
206-010-467-001	Collective Lever	4,800	1	\$1,145	\$0.24
CL42250-1	Freewheeling Unit Clutch	3,000	1	\$1,771	\$0.59
206-11-819-109	Tail Rotor Yoke	5,000	1	\$3,826	\$0.77
206-016-201-131	Tail Rotor Blade	2,500	2	\$4,910	\$3.93
206-040-410-101	Duplex Bearing	3,000	1	\$1,229	\$0.41
				<u>TOTAL</u>	<u>\$28.44</u>

Component Overhaul Intervals (Hours)

M/R Hub Assembly	2400	Transmission	4500	T/R Gearbox	6000
Swashplate and Suppo	4800	Freewheeling Unit	3000	Hydraulic Pump and Reser	3600
Mast Assembly	3000	T/R Hub Assembly	2500	Hydraulic Servoactuators	3600
		T/R Drive System	3000 / 3 yrs		

Prices and hours are subject to change without notice.

THESE DATA ARE PROVIDED FOR ILLUSTRATION PURPOSES. CONSULT MAINTENANCE DOCUMENTS AND BHT SPARE PARTS PRICING FOR CURRENT, OFFICIAL INFORMATION.



Unscheduled maintenance encompasses labor and parts replacement for major maintenance not covered under the formal Maintenance Manual requirements for inspections and overhauls. It also includes those additional maintenance requirements imposed by the manufacturer through issue of Service Bulletins.

The sample data for periodic inspections provide for some minor unscheduled maintenance tasks resulting from the inspection.

Power Plant Maintenance

The power plant requires periodic inspections and overhauls as does the airframe. The overhaul periods are based on the number of **operating hours** or on the number of **start cycles**, whichever is the first to be attained. Start cycles are a factor because the number of thermal cycles are important in the design of the turbine engine's

rotating components. Overhauls are performed by the engine manufacturer and/or at authorized facilities.

Power plant overhaul for the JetRanger can be performed for the engine as a unit, or for individual **modules** (modules are compressor, gearbox, turbine and combustor). Each module has its own overhaul period. Modular overhaul can be cost-effective for some operations and its use should be evaluated.

Engine or module exchanges can be made in lieu of overhaul. For details, contact the engine manufacturer or his authorized distributors/service centers. The sample costs are based on an average exchange.

Like the airframe, the power plant may also require unscheduled maintenance. An allowance is included in the sample.

INDIRECT COSTS:

Insurance

Insurance rates are based on claim experience, type of operation, and crew qualifications. Rates can be obtained from insurance agent/broker.

Facilities

Facilities can include hangar, workshop, parts storage area, tools, ground support equipment and administrative area as appropriate to the specific operation.

Crew Compensation

The number of aircrew personnel depends on the individual operation; i.e., whether the normal crew consists of one or two pilots, hours per day flown, backup requirements for illness, vacation, etc.

Financial Factors

Funding a helicopter purchase can be accomplished in a variety of ways; cash, short term note, long term note, partnership, etc. For investment accounting purposes, several **depreciation** methods also exist; straight line, double declining, sum of the years digits, etc. Value at resale is a significant factor. In many cases the used helicopter can be resold at the same dollar value at which it was purchased.

Miscellaneous Factors

Staff expense (other than aircrew and direct maintenance personnel), utilities, office expenses, etc.



OWNERSHIP ANALYSIS PROGRAM

Bell Helicopter Textron's Marketing Department has developed a computer program to detail ownership costs. It employs the following **input** information in order to reflect cost data for specific operationsz:

1. Helicopter model
2. Optional accessories
3. Flight hours per year
4. Fuel price per gallon
5. Hourly labor rate
6. Monthly hangar rental
7. Pilot's salary
8. Financing method
9. Insurance
10. Depreciation method

The following **output** information is then provided for a five year period:

Helicopter equipped price.

Maintenance and spare parts cost per year.

Cash flow per year and per flying hour.

Cost analysis per year and per flying hour.

Bell's Marketing personnel will assist in developing an ownership analysis once you provide the estimates of the ten input items.

THIS IS AN UNCONTROLLED DOCUMENT. THE DATA IS PRESENTED FOR GENERAL INFORMATION ONLY. SOME INFORMATION HAS BEEN SUPERCEDED SINCE ORIGINAL PUBLICATION. PLEASE REFER TO THE CURRENT PRODUCT SPECIFICATION BOOKLET FOR UP-TO-DATE STANDARD EQUIPMENT LIST & KIT WEIGHTS, PERFORMANCE, AND DIRECT OPERATING COST.

THIS IS AN UNCONTROLLED DOCUMENT. THE DATA IS PRESENTED FOR GENERAL INFORMATION ONLY. SOME INFORMATION HAS BEEN SUPERCEDED SINCE ORIGINAL PUBLICATION. PLEASE REFER TO THE CURRENT PRODUCT SPECIFICATION BOOKLET FOR UP-TO-DATE STANDARD EQUIPMENT LIST & KIT WEIGHTS, PERFORMANCE, AND DIRECT OPERATING COST.

Bell Helicopter **TEXTRON**

A Subsidiary of Textron Inc.

P.O. Box 482, Ft. Worth, Texas 76101,
Phone: (817) 280-8747, Fax: (817) 280-3631
www.bellhelicopter.textron.com

**BELL HELICOPTER TEXTRON
DIVISION OF TEXTRON CANADA LTD.
12,800 rue de l'Avenir Mirabel, Quebec, Canada J7J1R4
Phone: (514) 437-2729 Fax: (514) 437-2066**

©1999 Bell Helicopter Textron Inc., All Rights Reserved.

The data set forth in this brochure are general in nature and may vary with conditions. For performance data and operating limitations for any specific flight mission, reference must be made to the approved flight manual.